

ТРАНСПОРТИРОВАНИЕ И СКЛАДИРОВАНИЕ БИТУМОВ



ДОСТАВКА БИТУМОВ

В ГОРЯЧЕМ ВИДЕ

В ХОЛОДНОМ ВИДЕ







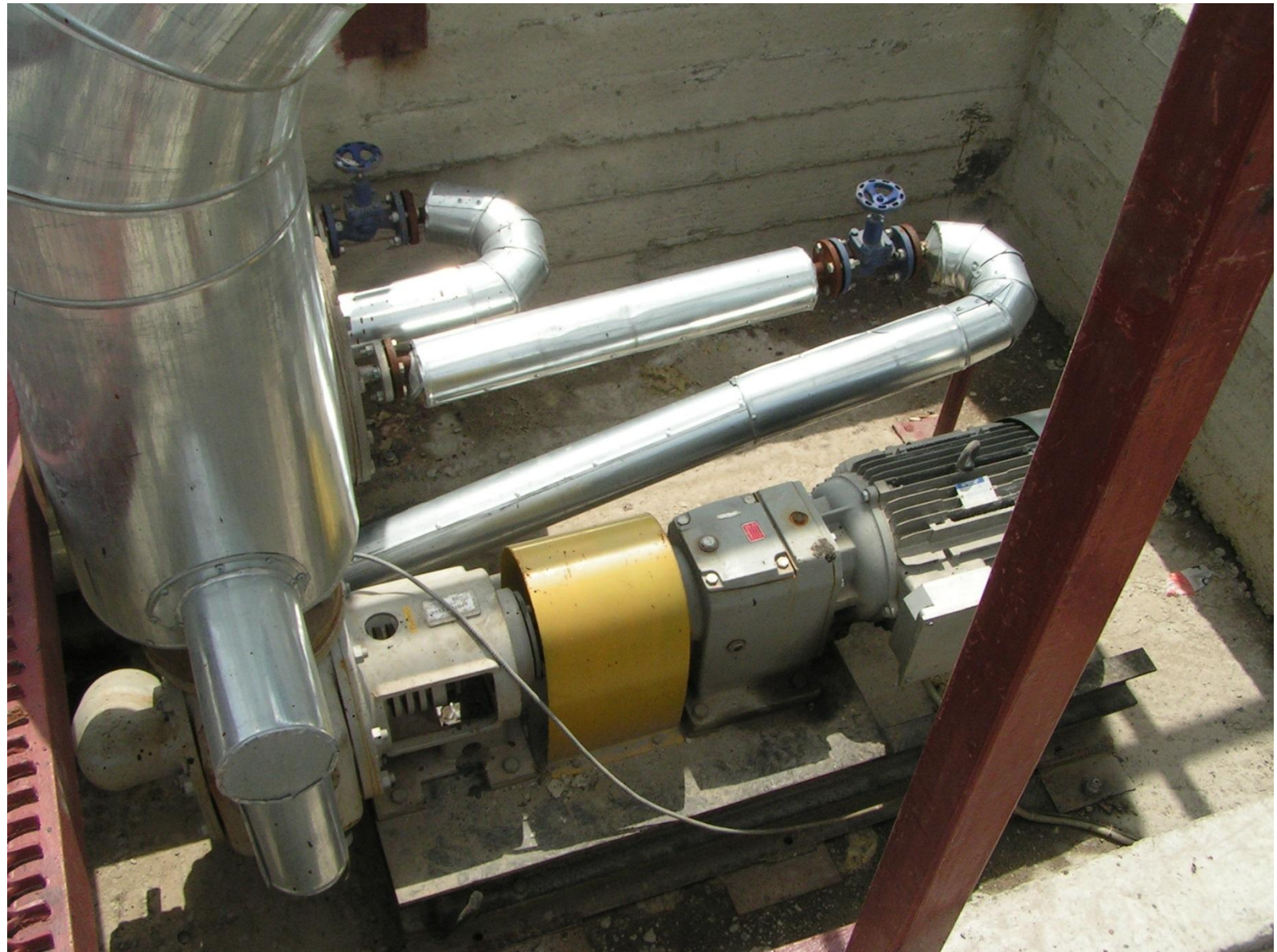

ЯМНЫЕ ХРАНИЛИЩА



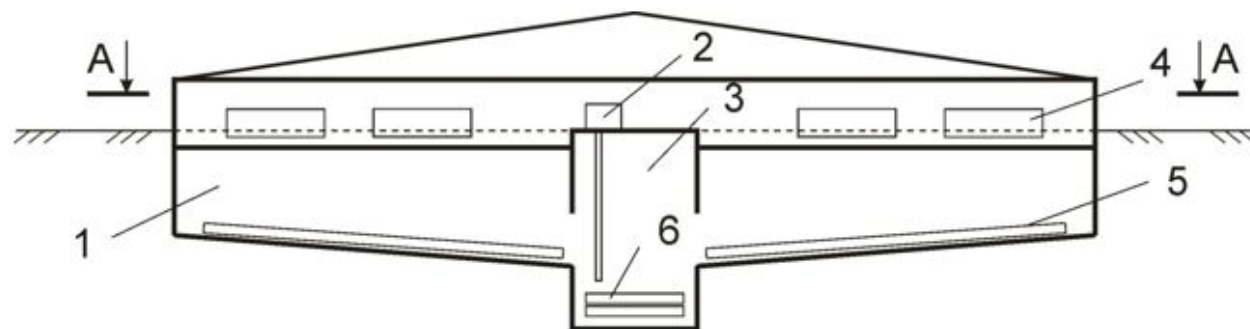

A-A

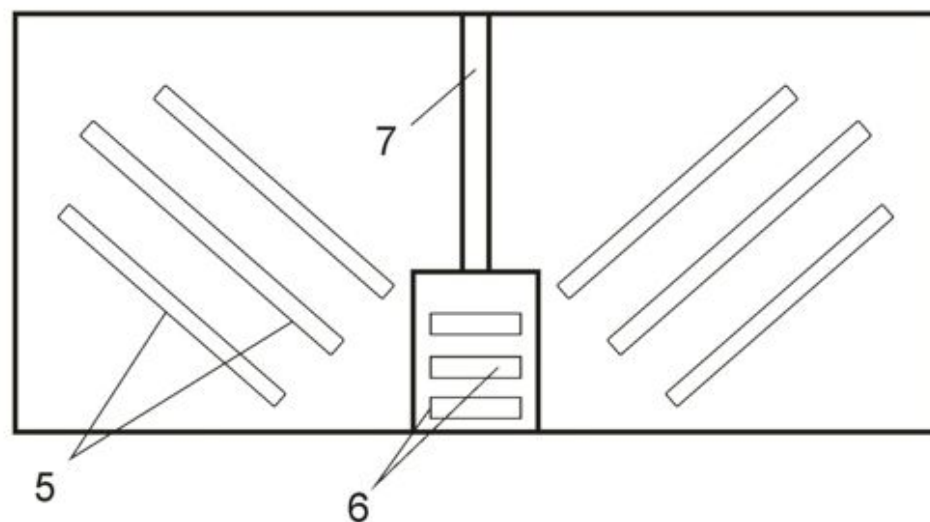

Двухсекционное ямное битумное хранилище:

1 – отсек хранения, 2 – насосная станция, 3 – приямок, 4 – технологическое отверстие для заполнения отсеков хранения, 5 – нагревательные элементы отсека хранения, 6 – нагревательные элементы приямка, 7 – разделительная стенка













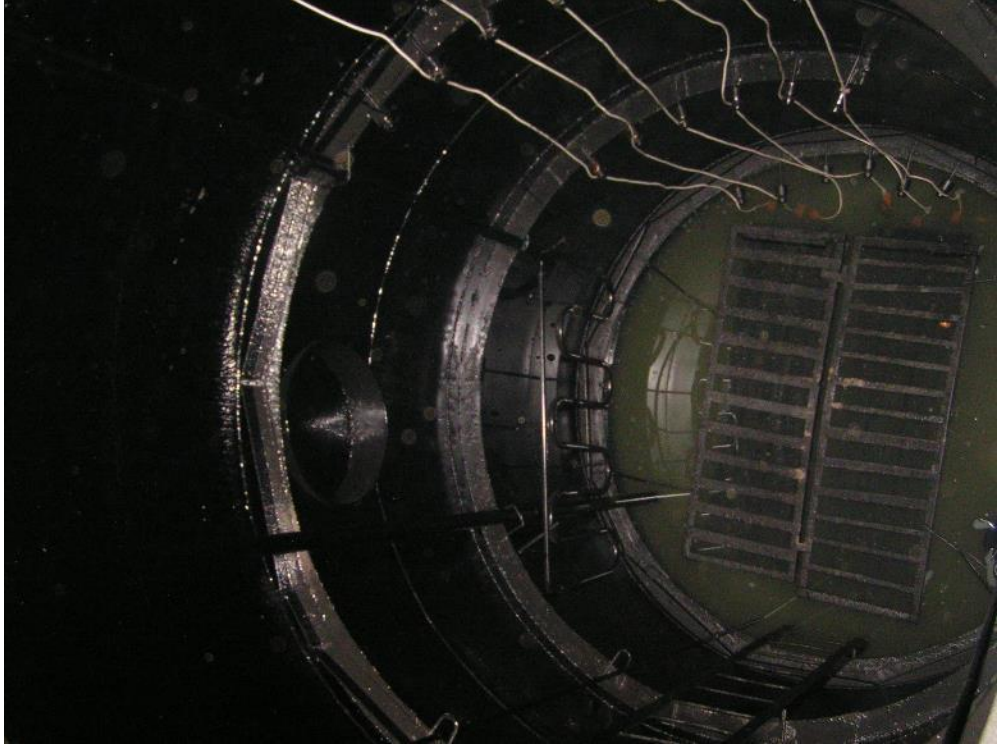

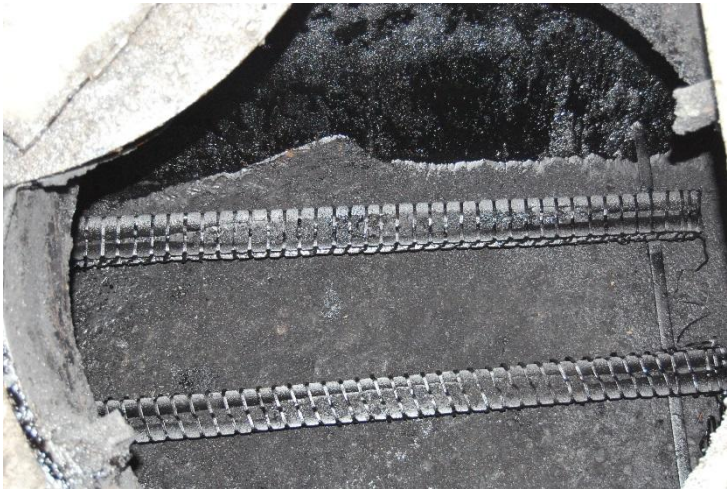

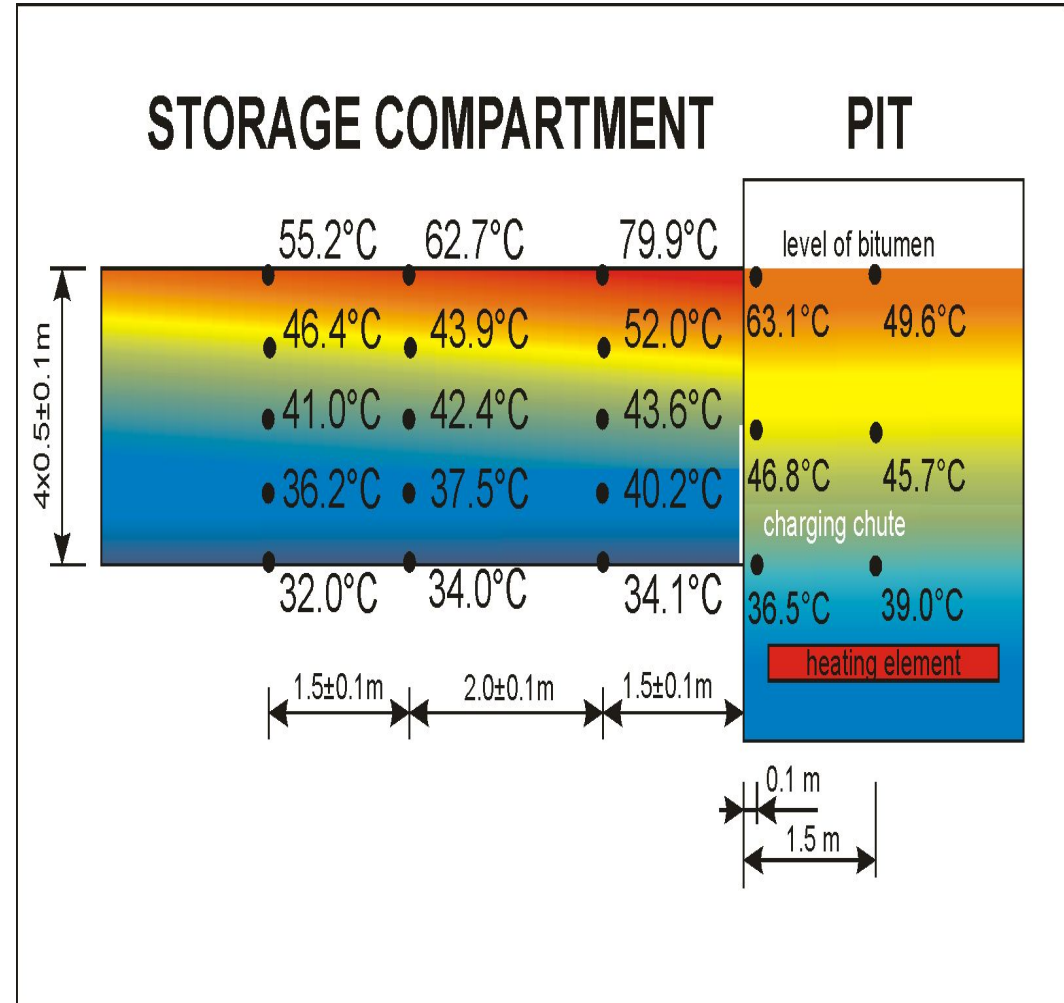
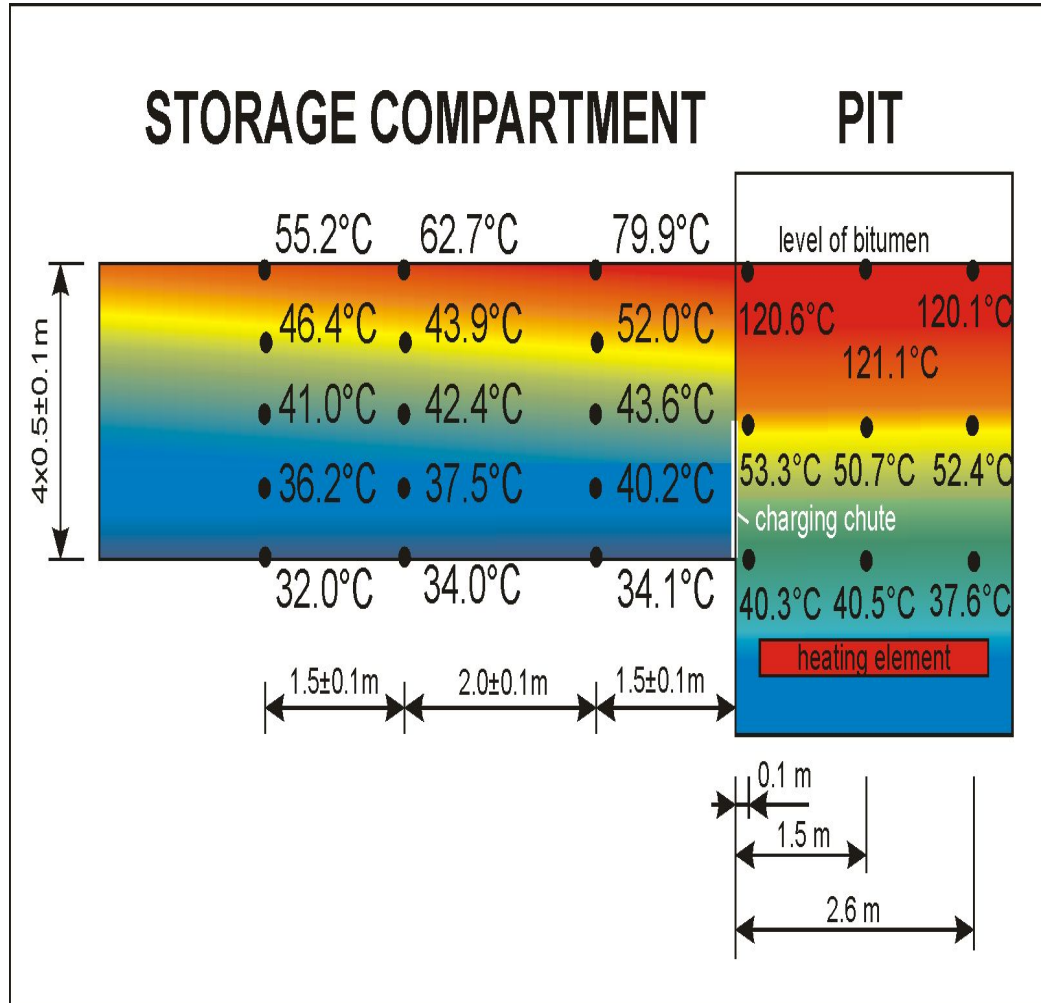



Температура битума, °С, на расстоянии от дна резервуара							Температура, °С	
1 м	2 м	3 м	4 м	5 м	6 м	7 м	Воздуха	На поверхности тепловой изоляции
137,8	137,9	138,0	138,1	138,2	138,2	138,2	30	39



СКЛАДЫ ФАСОВАННОГО





Flagma.ru



BIG BAG

**КЛОВЕРТЕЙНЕ
Р**



**БОЧК
А**



POLYCUBE

