



цикл  
пешеходных  
экскурсий

№2  
РИТМ

ГОРОД  
КАК КАРТИНА

17  
июля  
15.00



## Основные виды метрических рядов

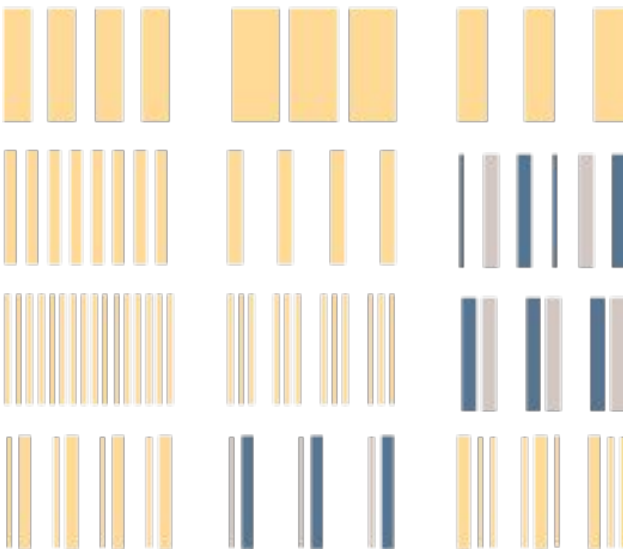

## Основные виды ритмических рядов

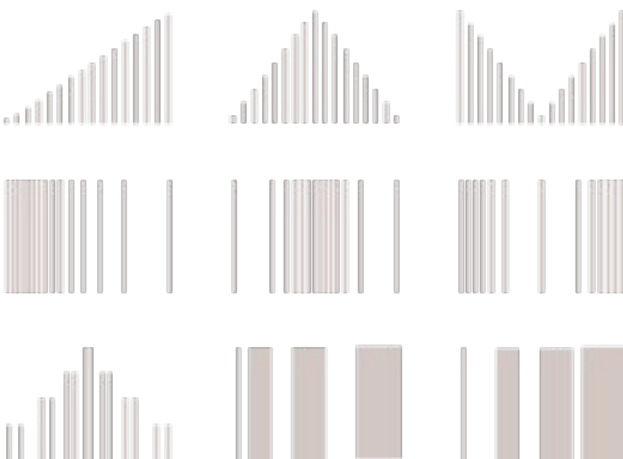

1

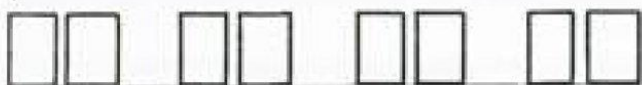

2



3

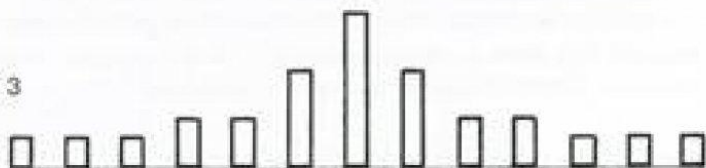

4

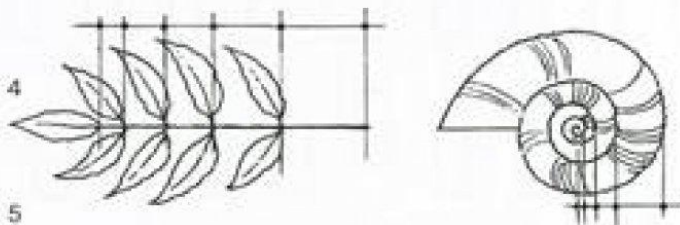

5



6



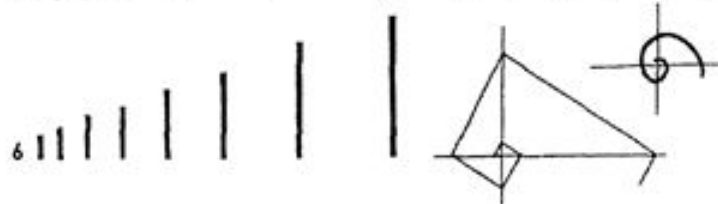

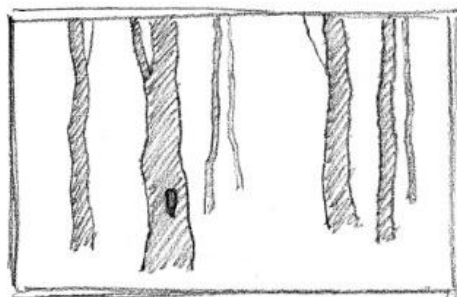
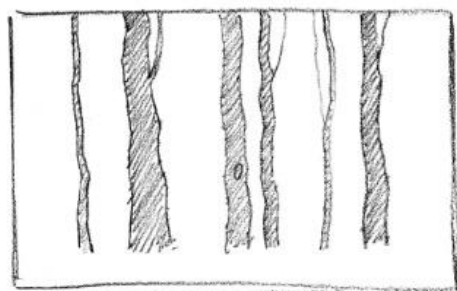
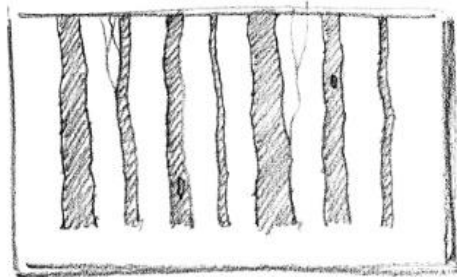
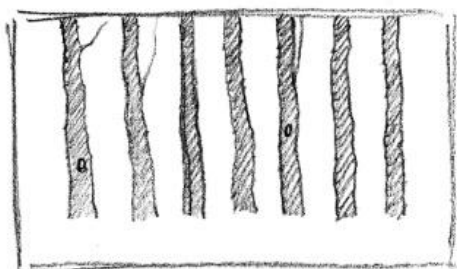

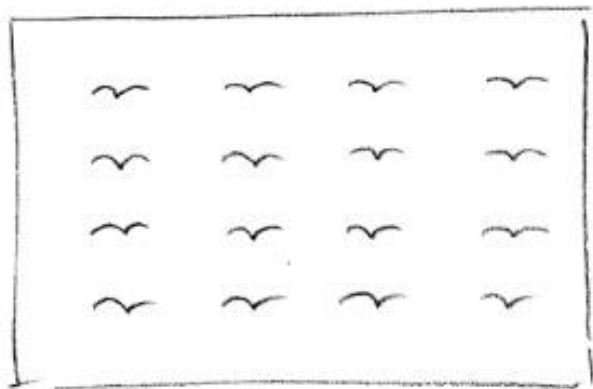



Диего

Веласкес

«Сдача

Бреды»

1634–1635



Александр

Родченко

«Лестница»

1929



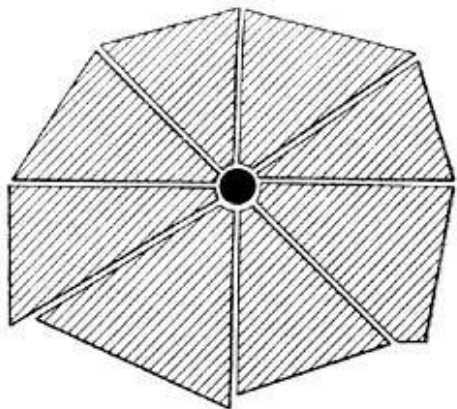

РАДИАЛЬНАЯ

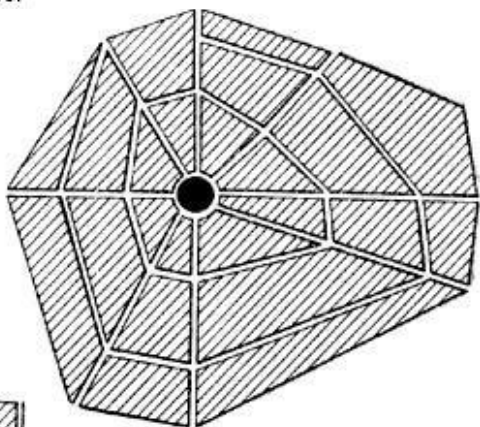

РАДИАЛЬНО - КОЛЬЦЕВАЯ

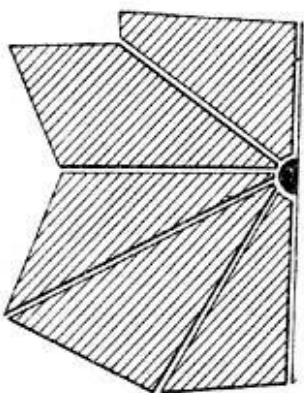

ЛУЧЕВАЯ

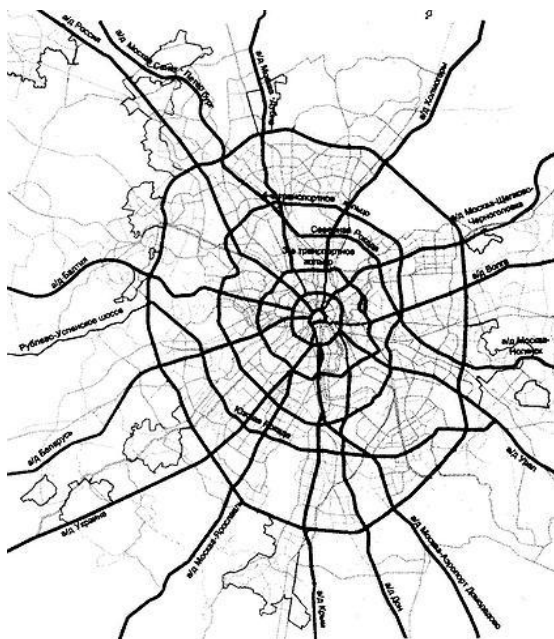

— существующие магистрали  
 — проектируемые магистрали

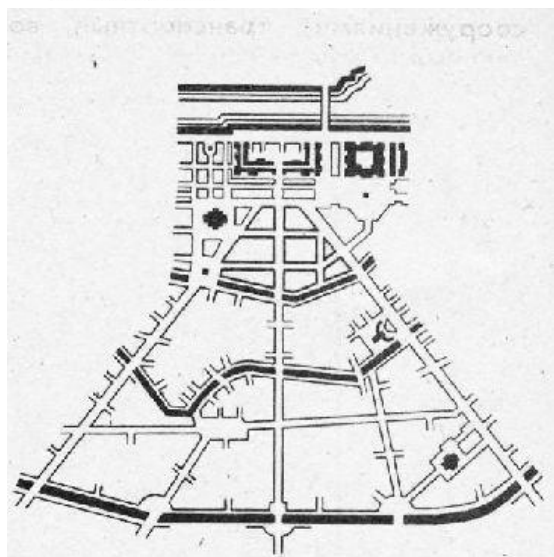

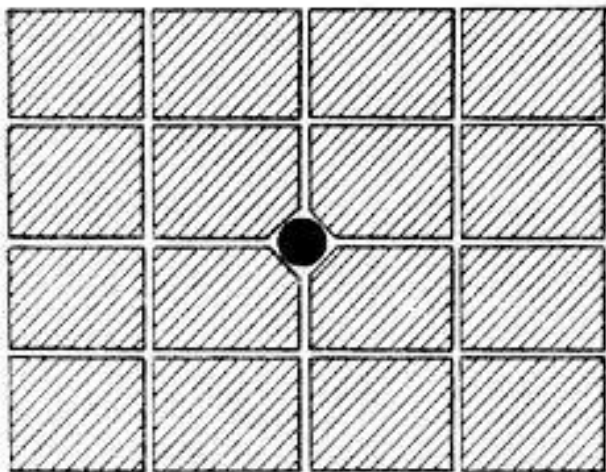

ПРЯМОУГОЛЬНАЯ

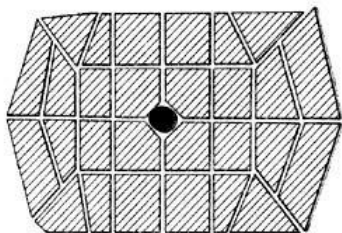

КОМБИНИРОВАННАЯ

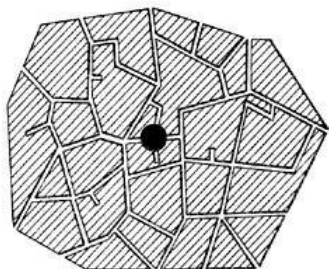

ПРОИЗВОЛЬНАЯ

# Генеральный план Манхэттена

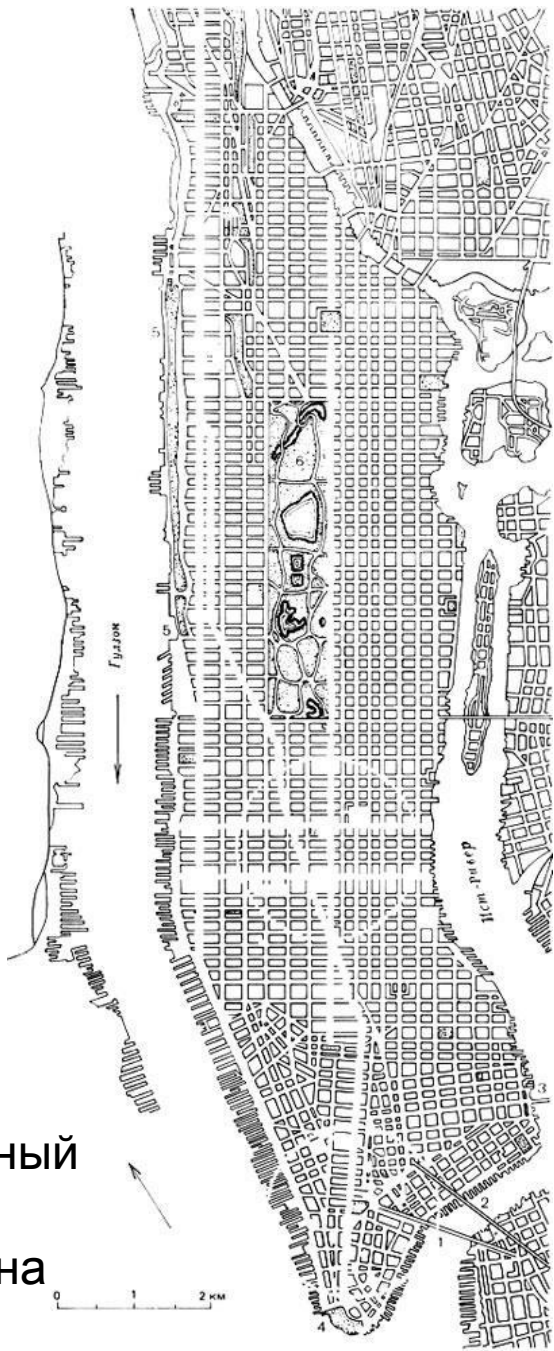

**Геометрический план  
Симбирского наместничества  
города Самары снят  
в 1782 году мая 14-го дня  
уездным землемером Сахаровым**

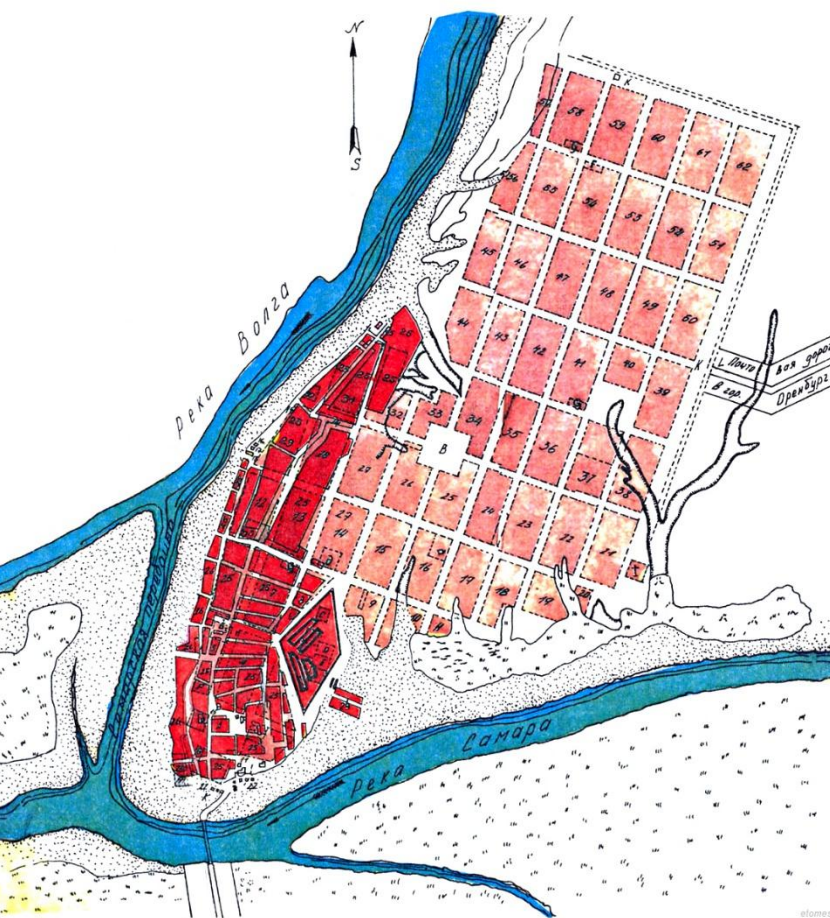







Здание Губернской Земской  
управы  
1898-1900



Александр Зеленко





Фонарь Белиша

1930-е



Иэн Макмиллан

Фото для обложки альбома

Beatles «Abbey Road»

1969





Автомобиль

Константина Головкина

1904



Конка в Самаре, 1914



Трамвай на ул. Саратовской, 1915

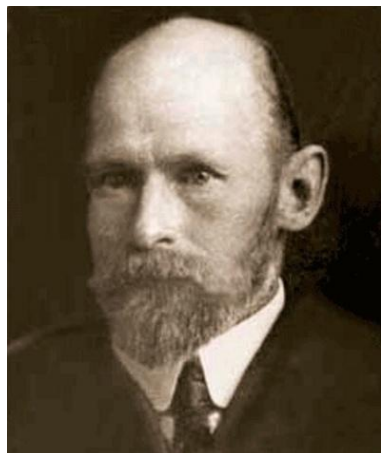

Павел  
Антонови  
ч  
Суткевич





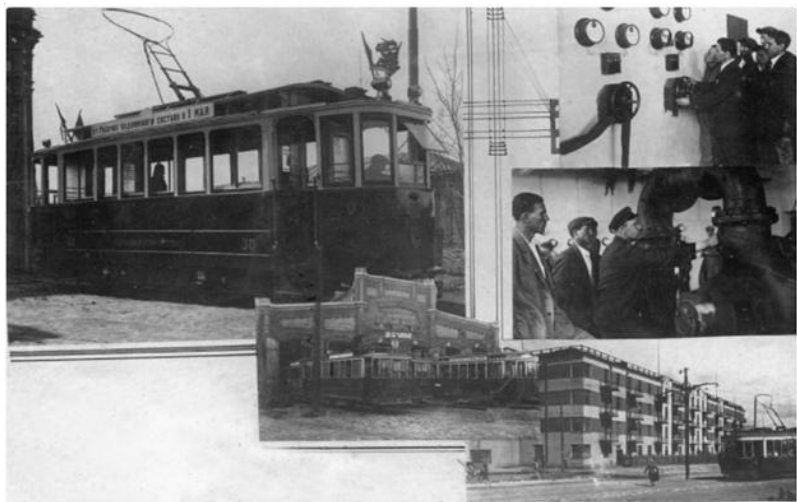

Растет и улучшается коммунальное хозяйство города.





