

Решение любой задачи— “это хорошее знание теории, немного смекалки и простая арифметика”

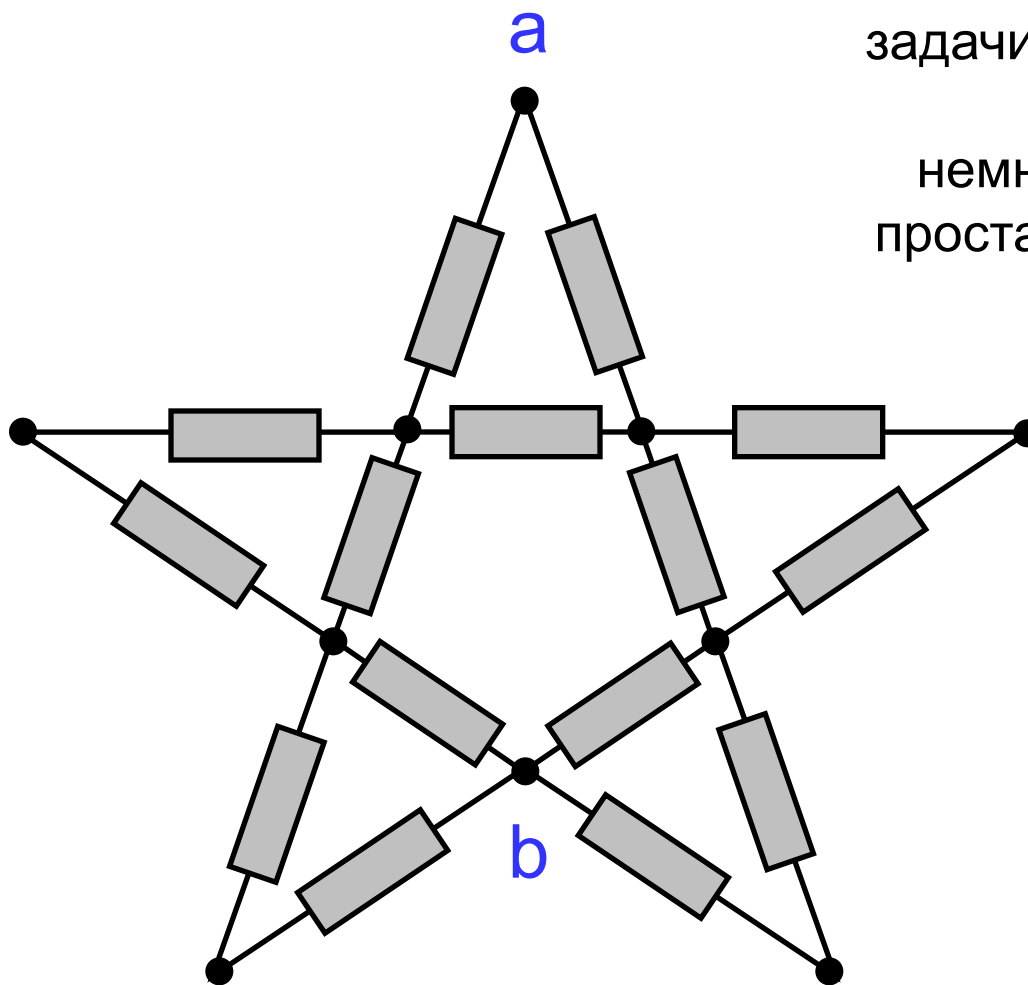

Решение задач на расчет электрических цепей.

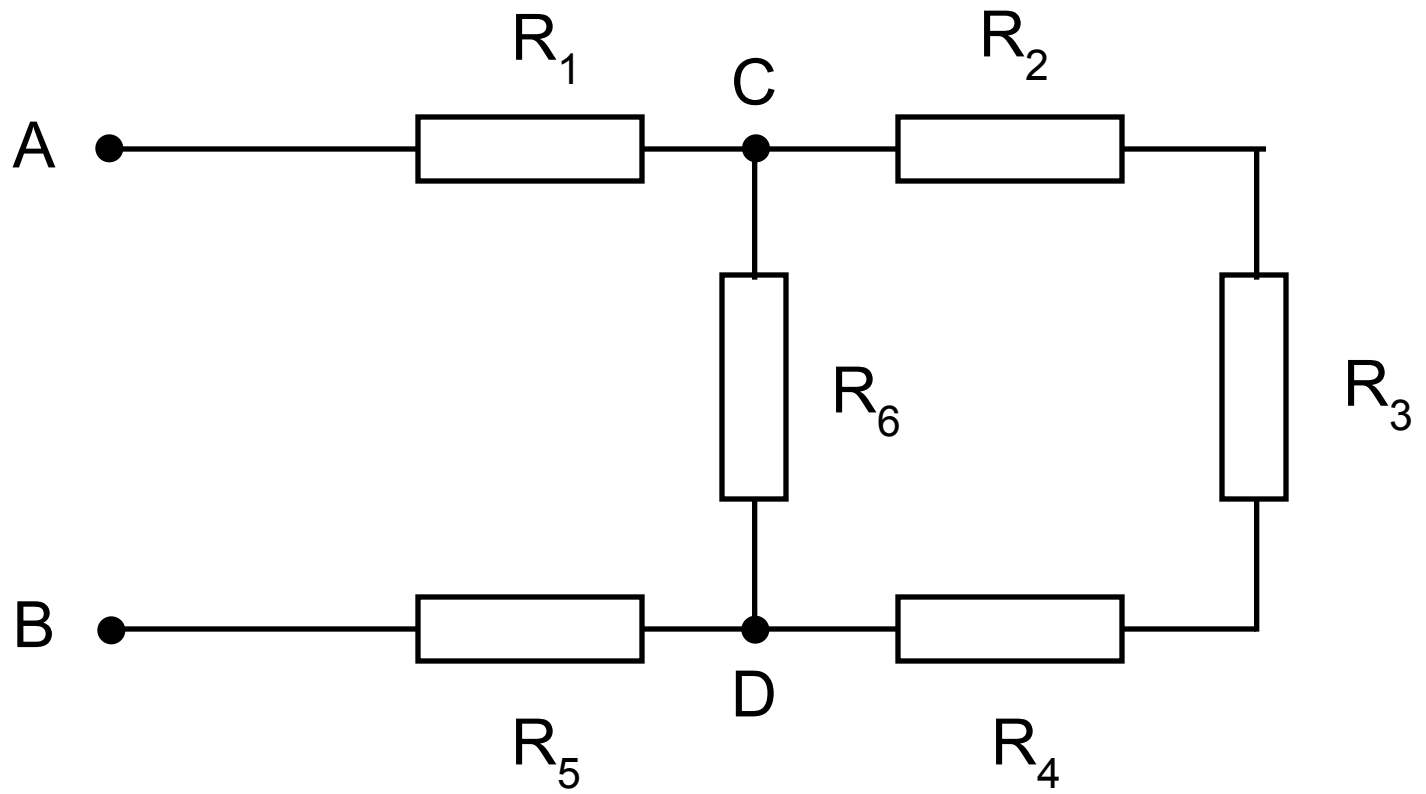

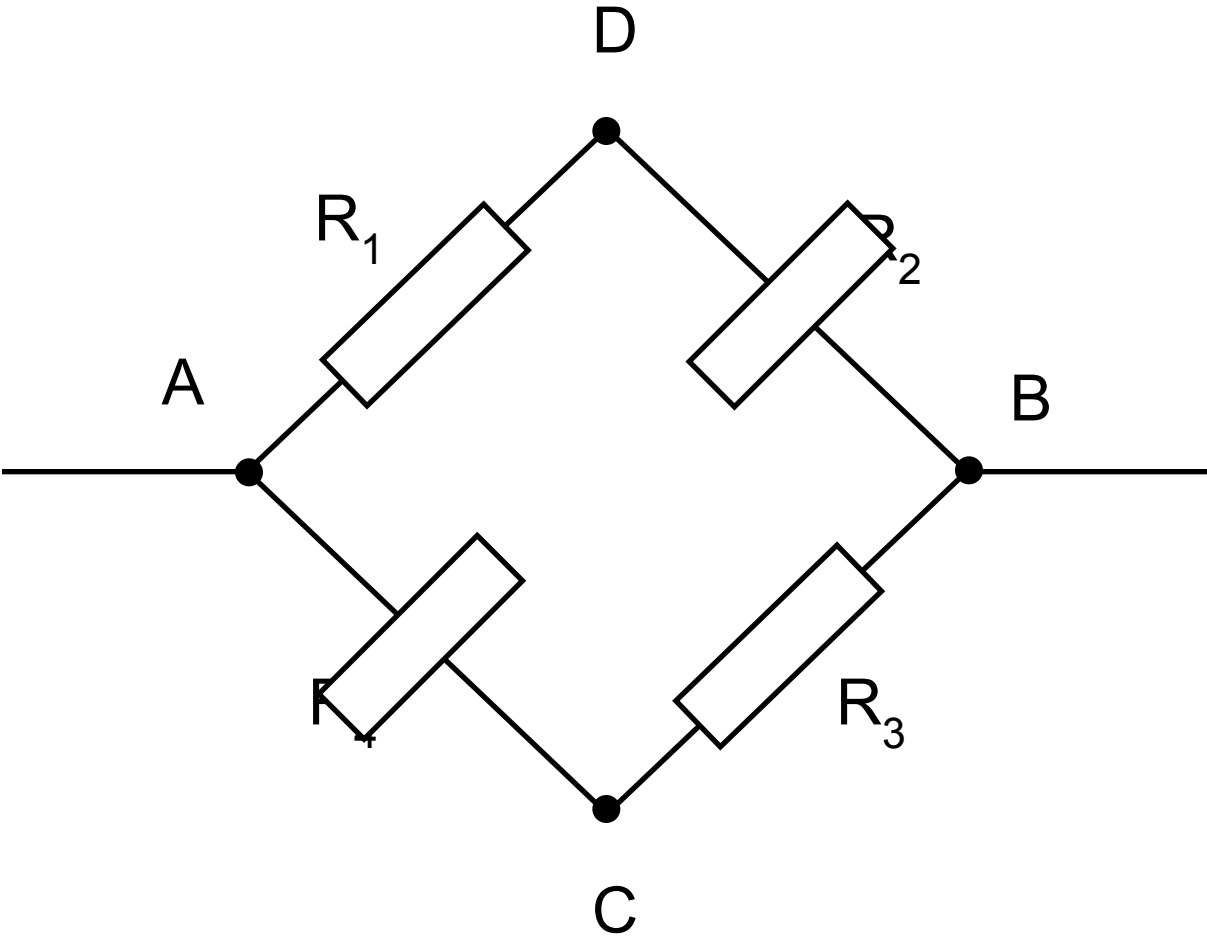

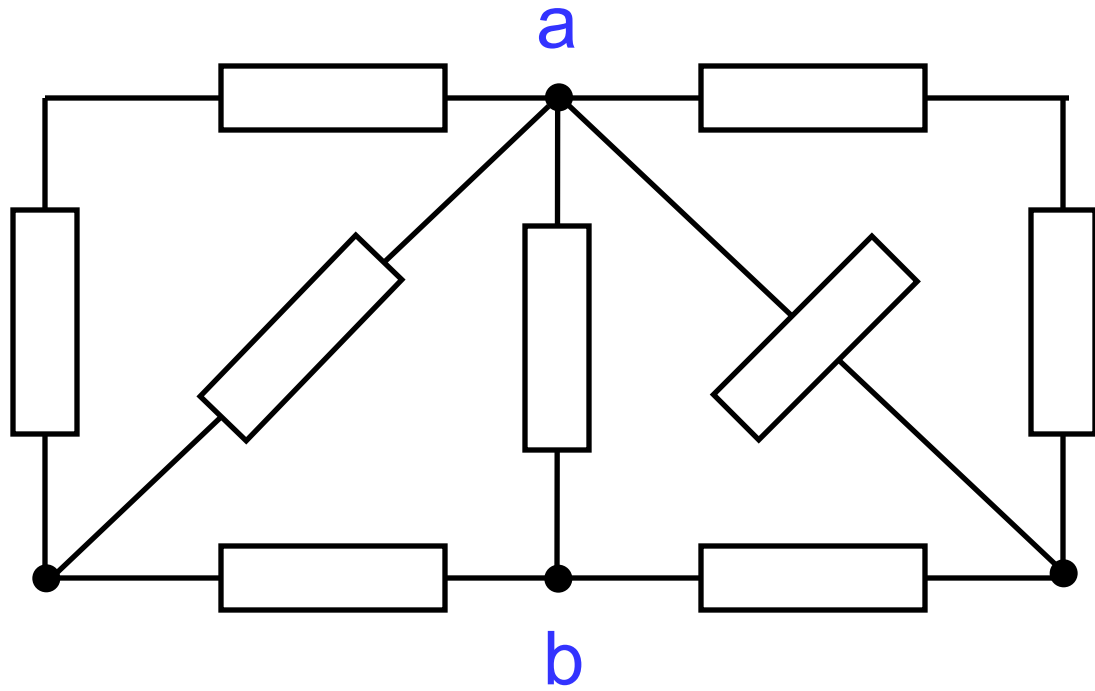
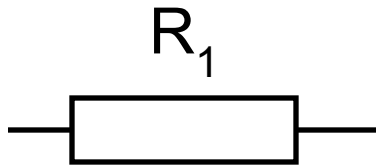

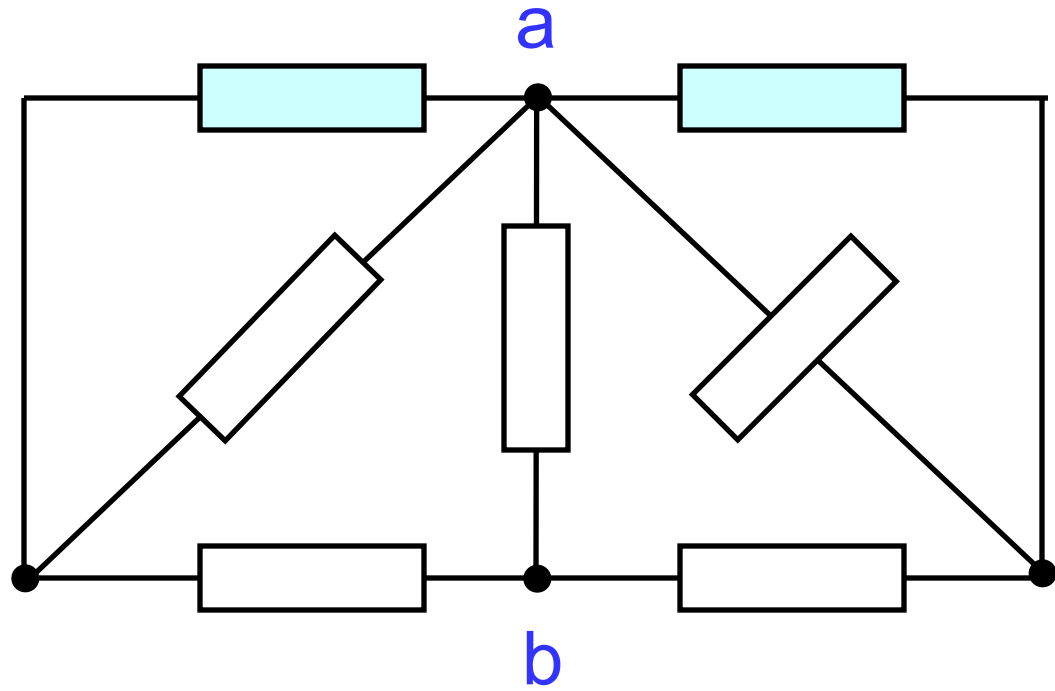
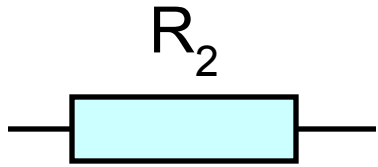
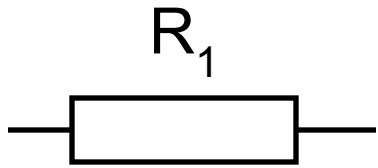

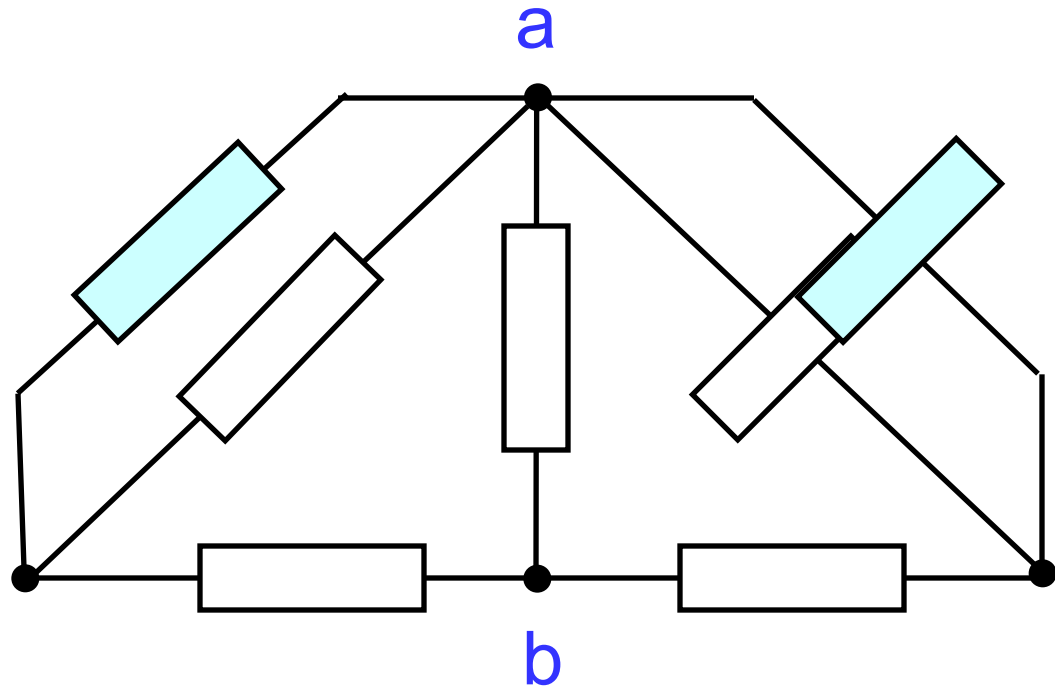
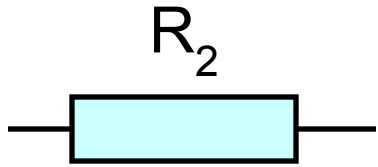
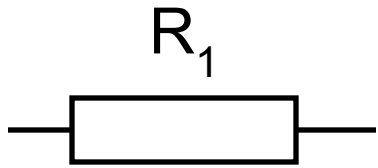

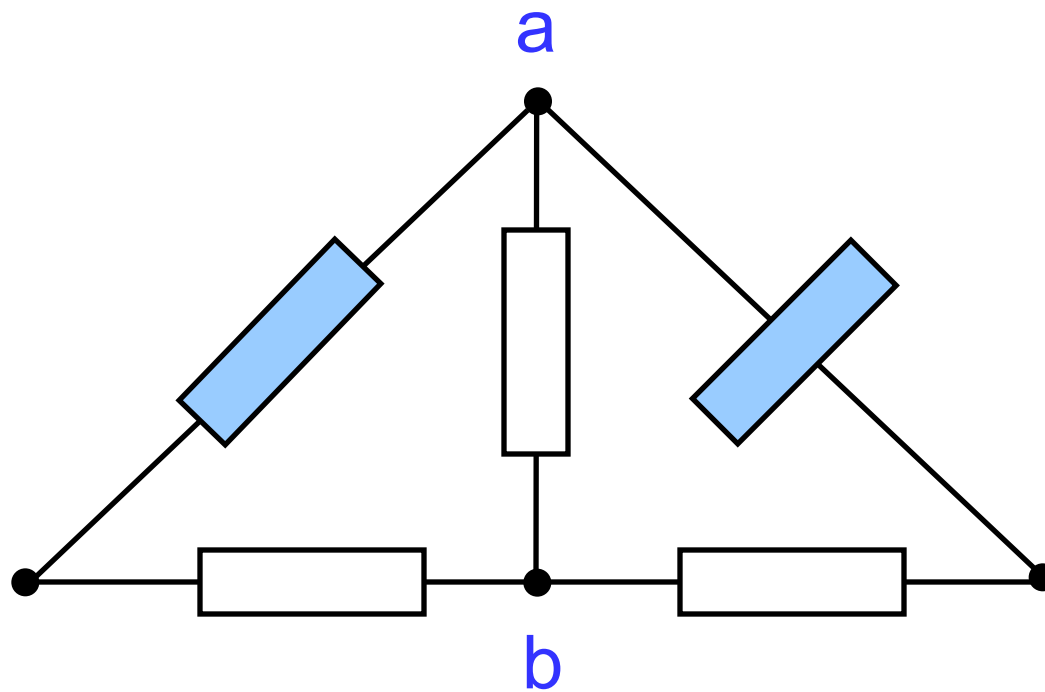
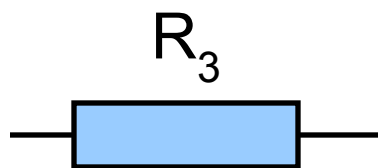
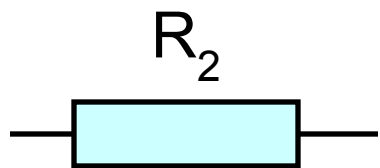
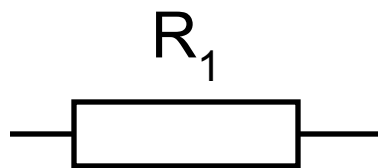

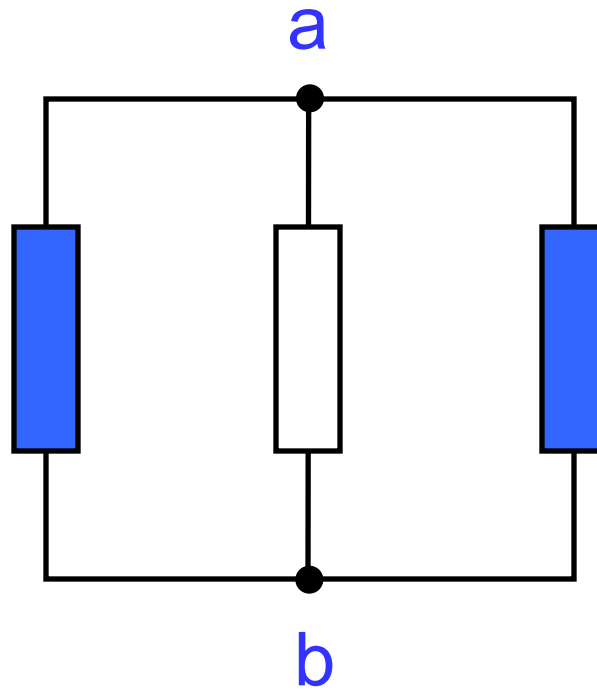
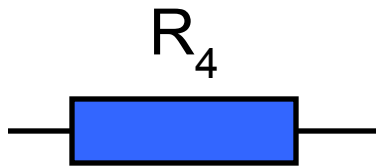
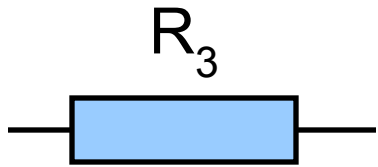
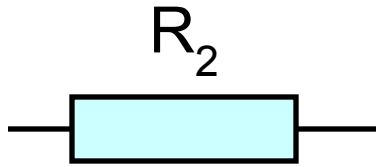
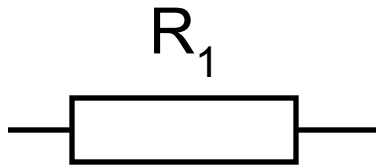

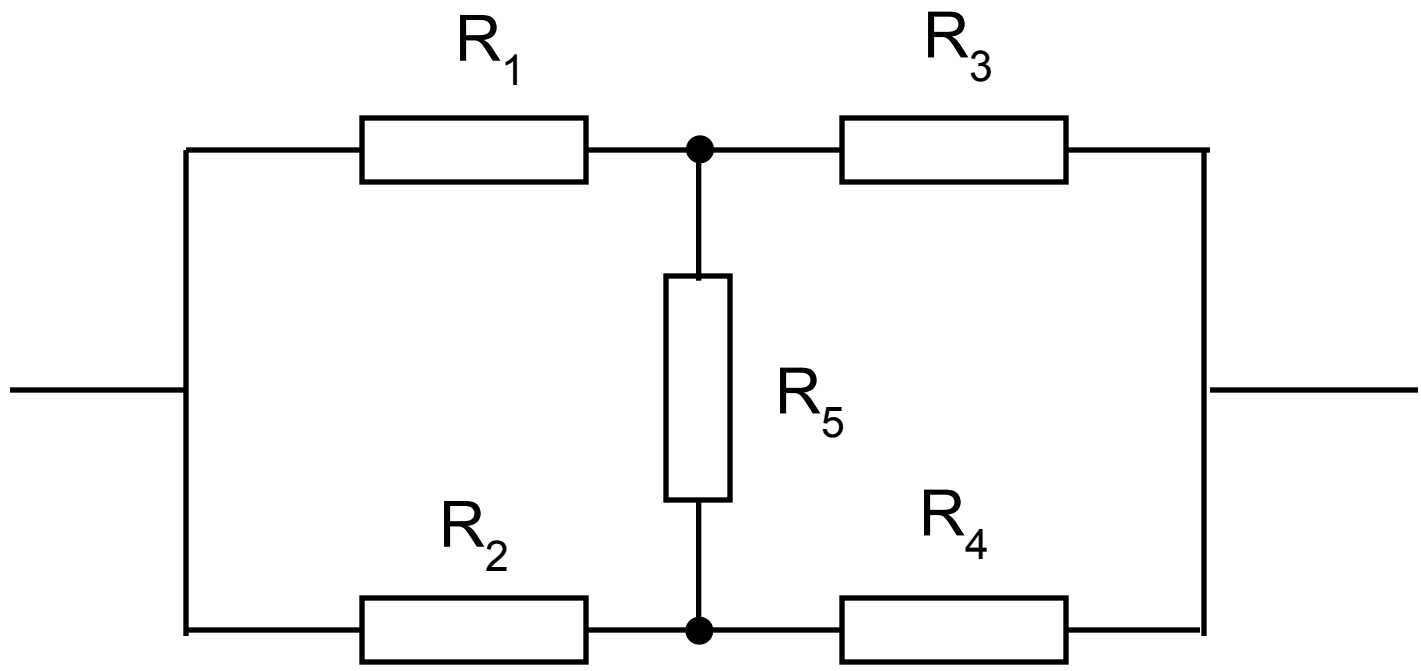

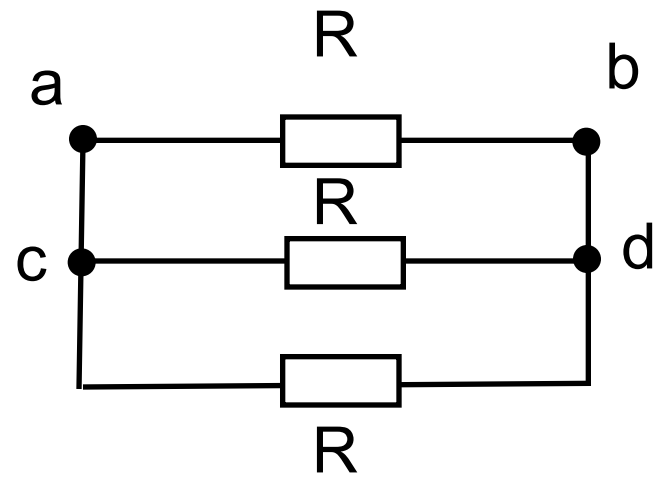
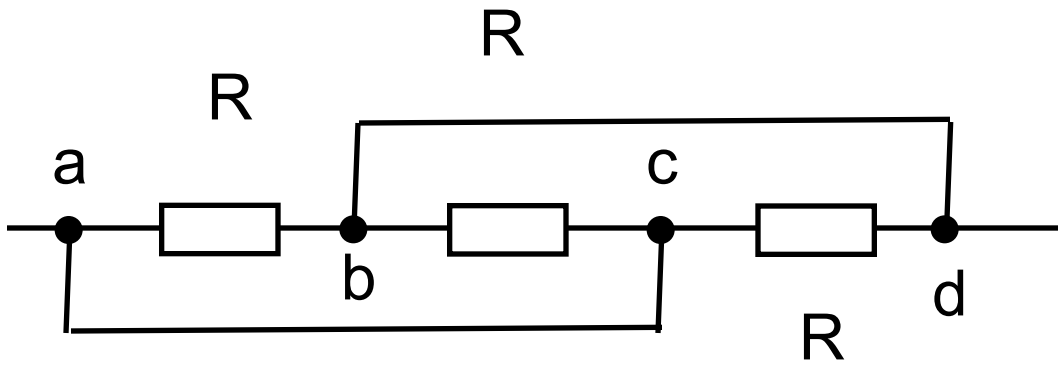

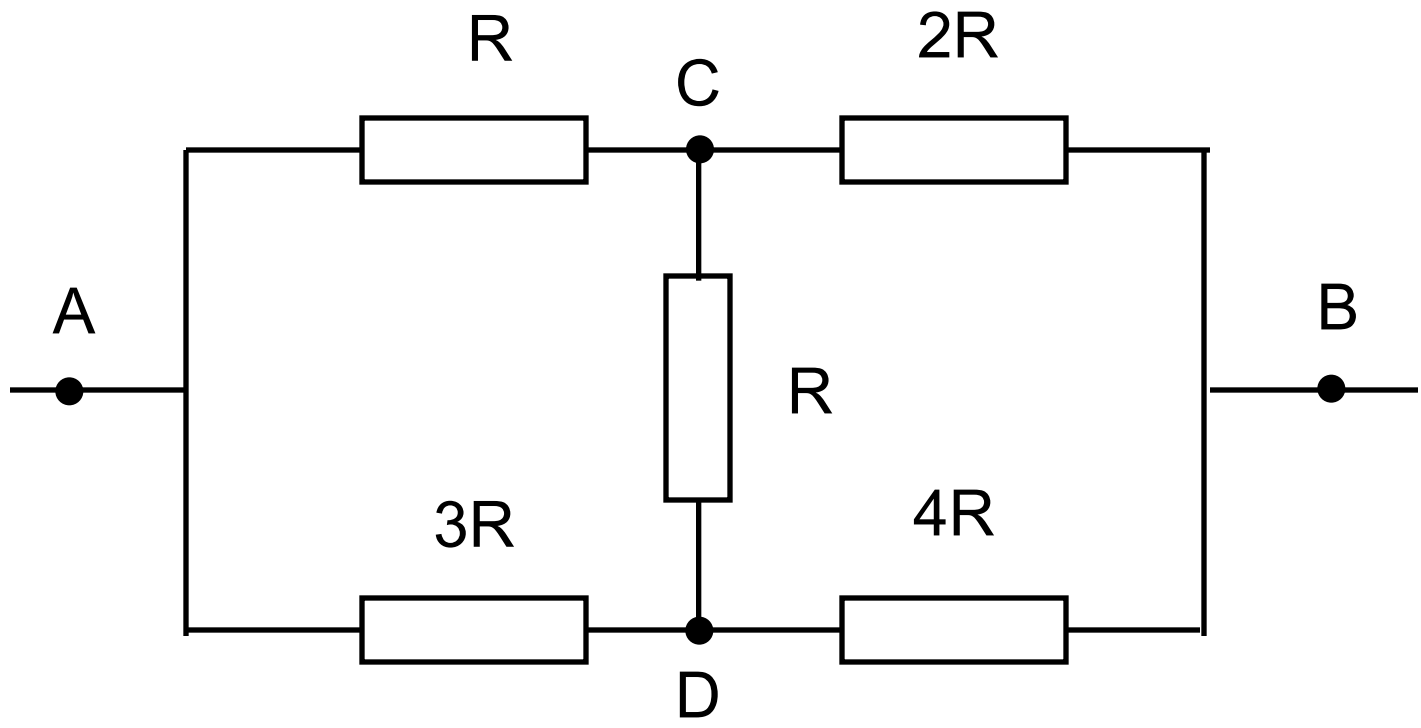

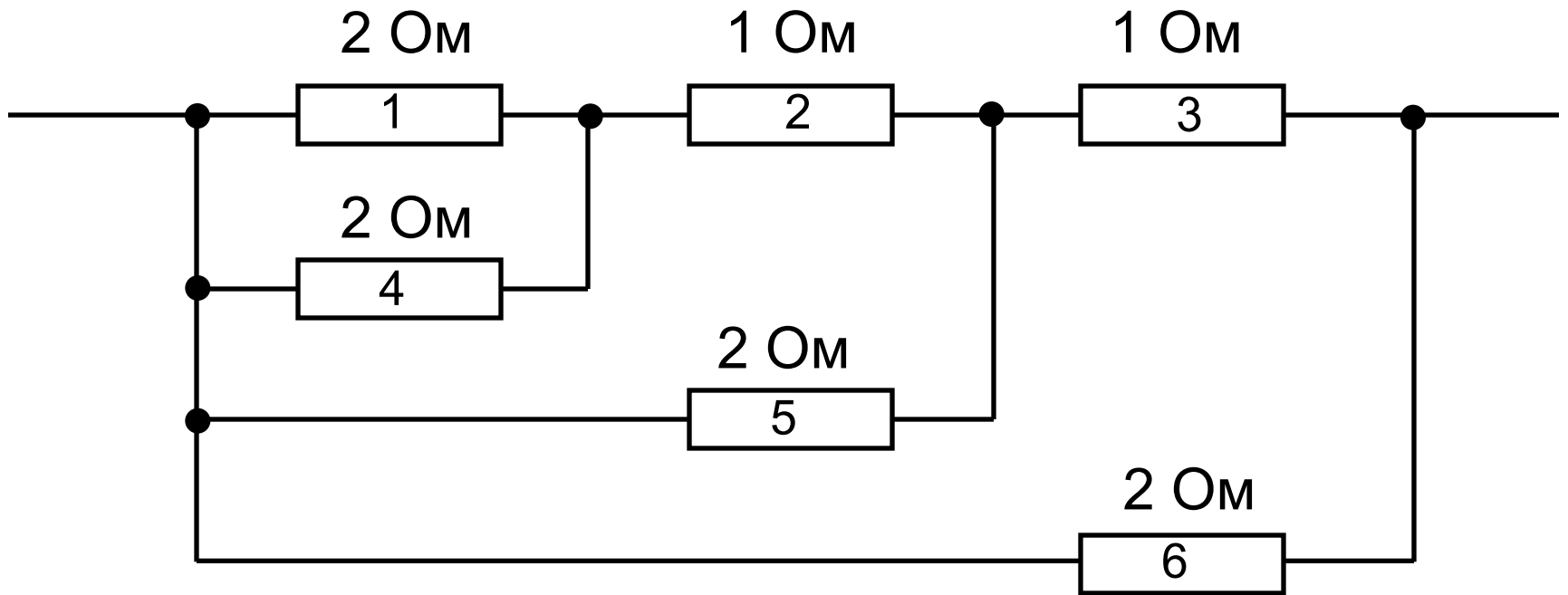

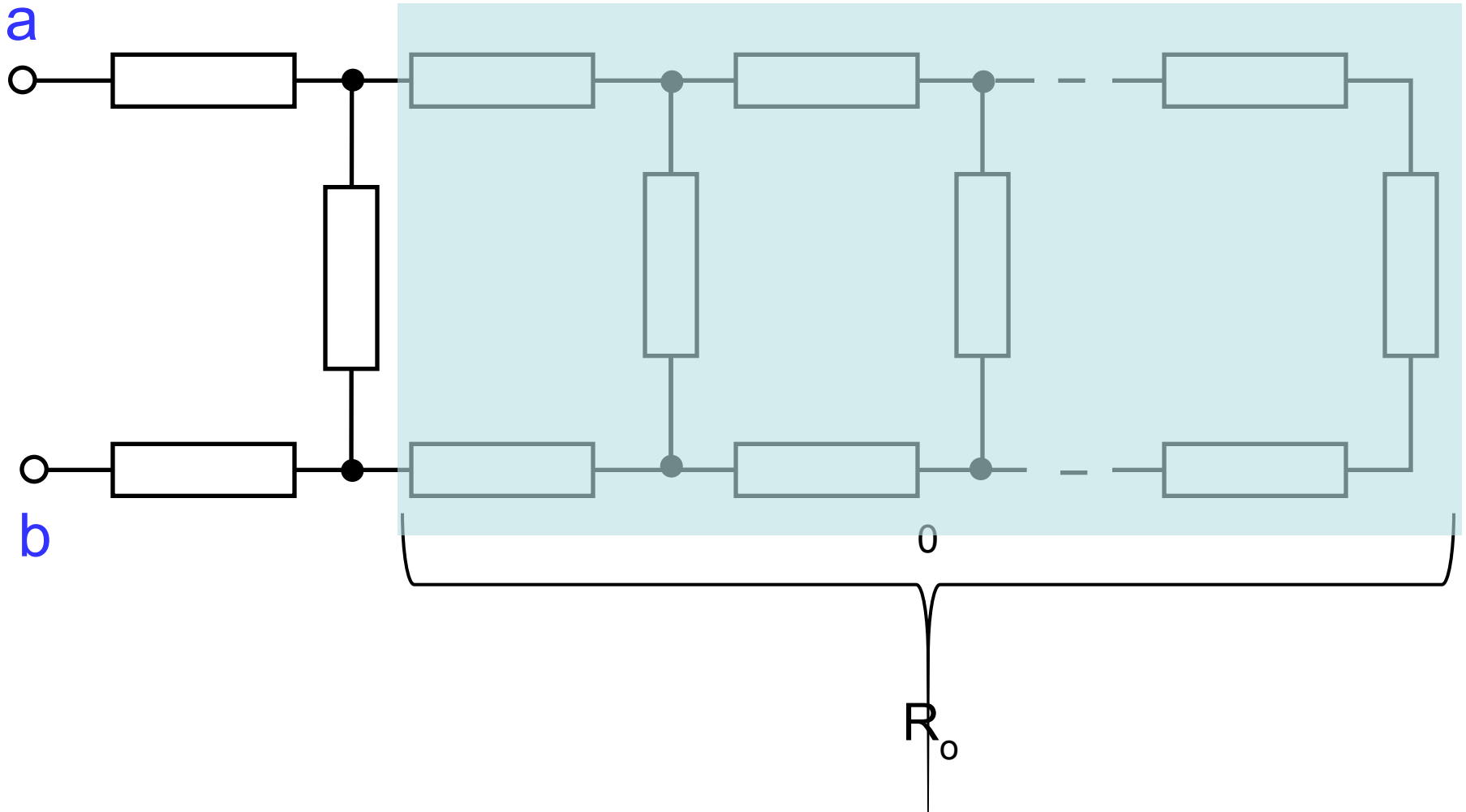
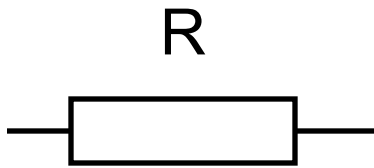

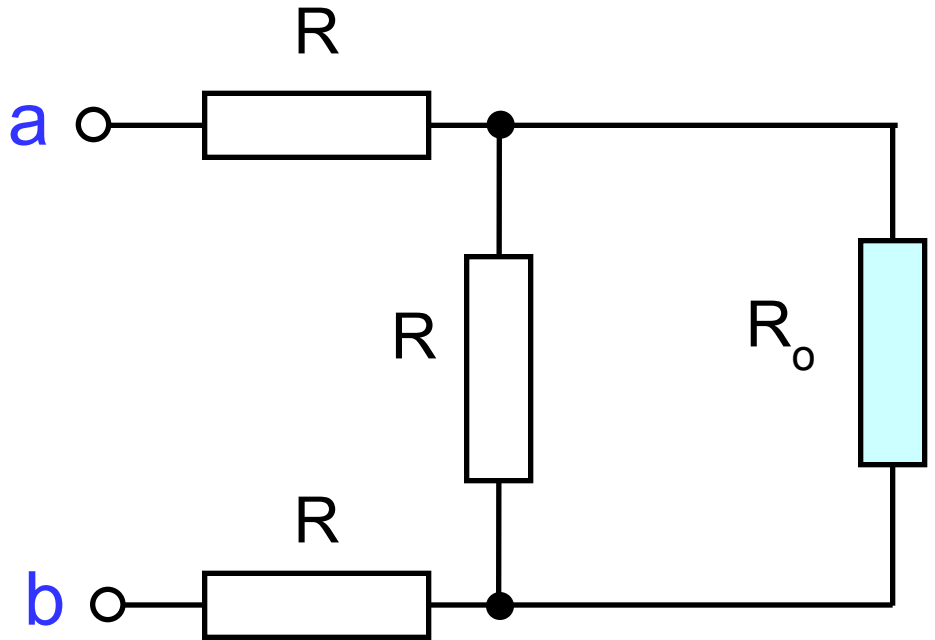
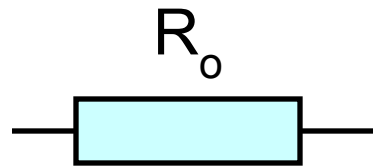
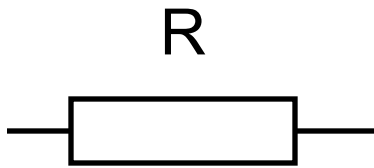

$$R_0 = R + \frac{R \cdot R_0}{R + R_0} + R_0$$

$$R_0 = R(1 + \sqrt{3})$$

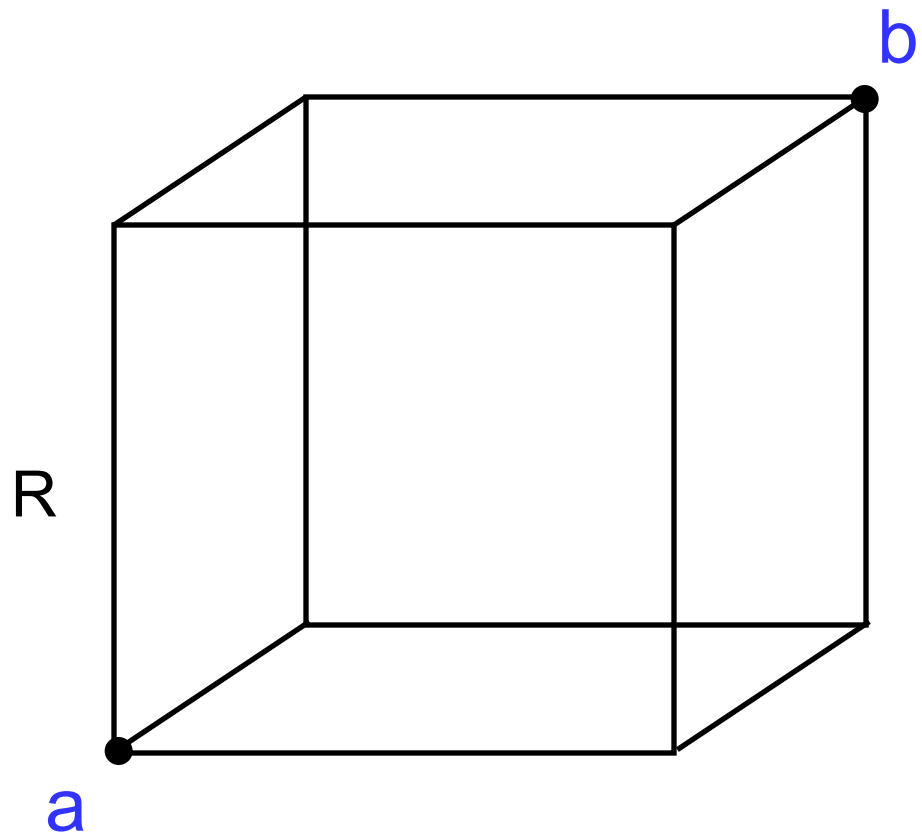

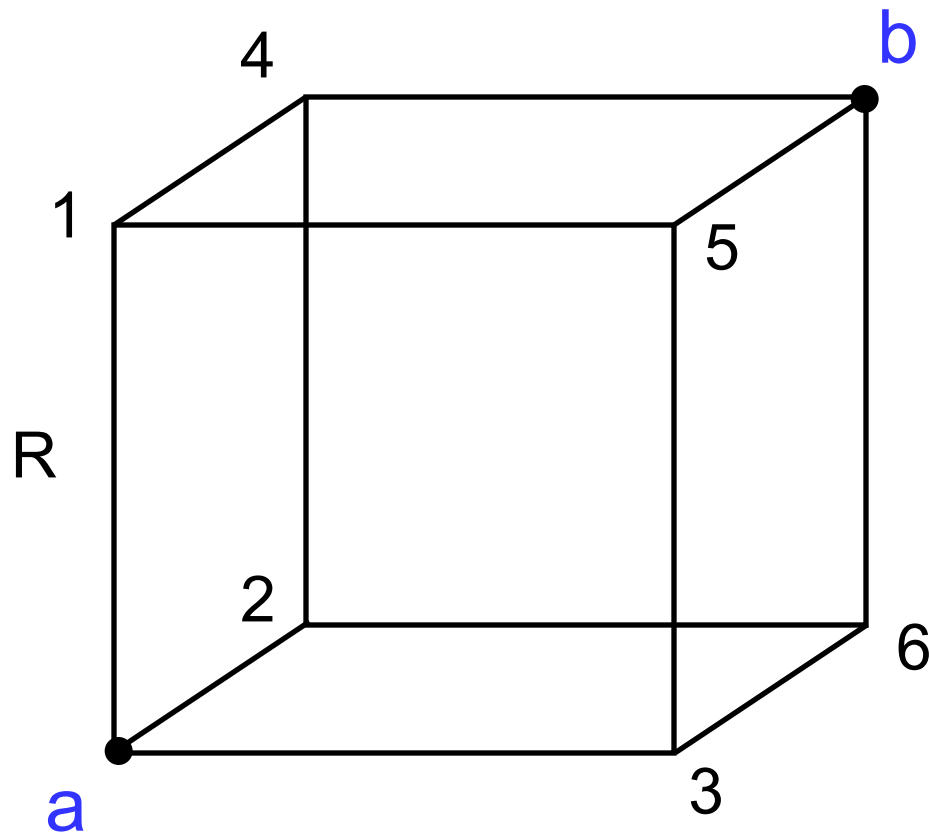

$$R_o = \frac{5}{6} R$$

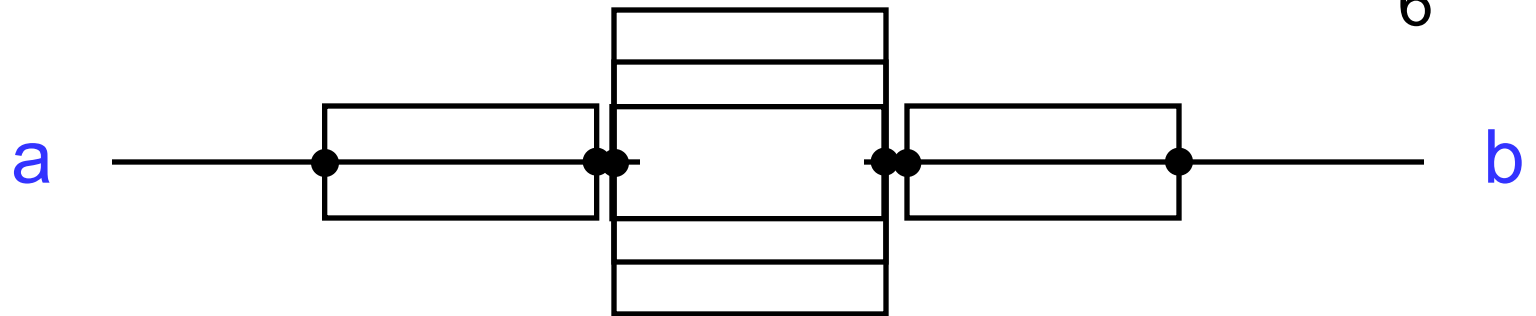

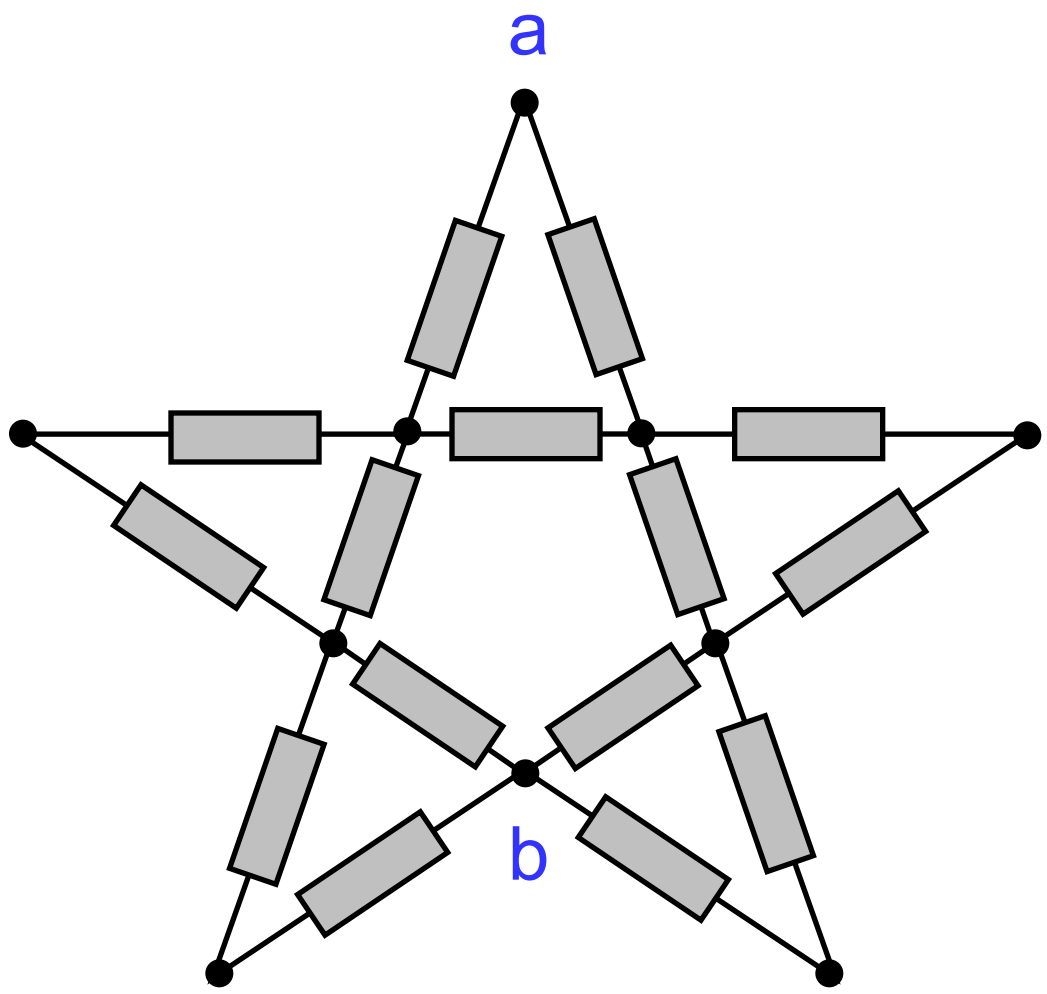
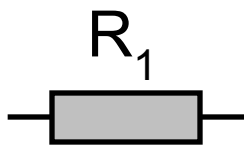

Домашнее задание:

Слайд № 18 решить.

Придумать свою задачу (пример: звезда, дом, машина, зайчик...), решить ее, прислать мне на эл почту.

pigalinajulia@yandex.ru