

The Elizabethan Period

Plays and Poetry

1558-1603

HISTORY OF THE PERIOD

AGE OF EXPLORATION-

- John Cabot reaches Newfoundland in 1497
- Francis Drake attacks Spanish ships in 1572
- Walter Raleigh founds Roanoke Colony in 1584

RELIGIOUS TURMOIL-

- Elizabeth's predecessor Mary, had executed 300 Protestants and restored Catholicism.
- Elizabeth maintained a policy of tolerance, despite several Catholic plots against her life.

The English Nation

Centralization of monarchy
focused money and power in
London, around court.

Idle aristocracy +
Improving economy
Many willing patrons

```
graph TD; A[Centralization of monarchy focused money and power in London, around court.] --> C[Strong personality of Queen and long reign attracted many creative types]; B[Idle aristocracy + Improving economy Many willing patrons] --> C; C --> D[Focus on arts and changing language contributed to literary explosion]; E[New playhouses and evolution of drama provided public entertainment] --> D;
```

Strong personality of Queen
and long reign attracted
many creative types

New playhouses and
evolution of drama provided
public entertainment

Focus on arts and changing
language contributed to
literary explosion



DRAMA

POETRY

- Thomas Kyd (1558-1594)

The Spanish Tragedy

- Kit Marlowe (1564-1593)

Doctor Faustus

- Ben Jonson (1572-1637)

Volpone

- Edmund Spenser (1552-1599)

The Faerie Queene

- Sir Philip Sidney (1554-1586)

Astrophel and Stella

Sonnets and Soldiers

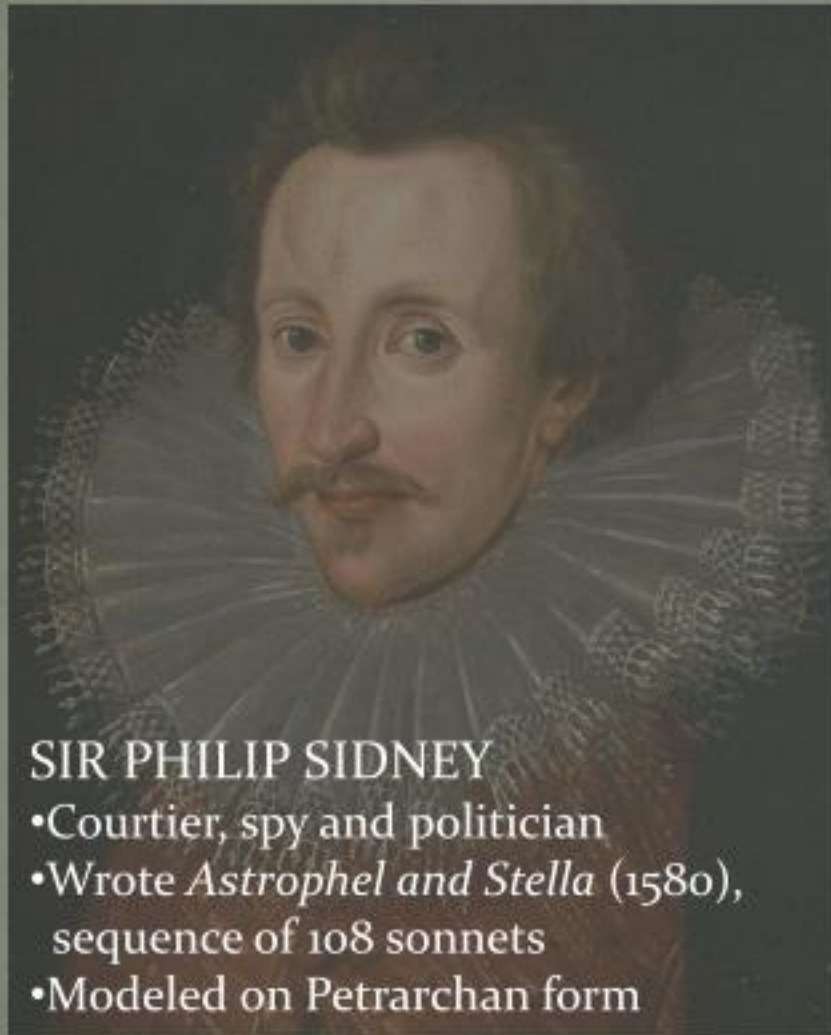

SIR PHILIP SIDNEY

- Courtier, spy and politician
- Wrote *Astrophel and Stella* (1580), sequence of 108 sonnets
- Modeled on Petrarchan form

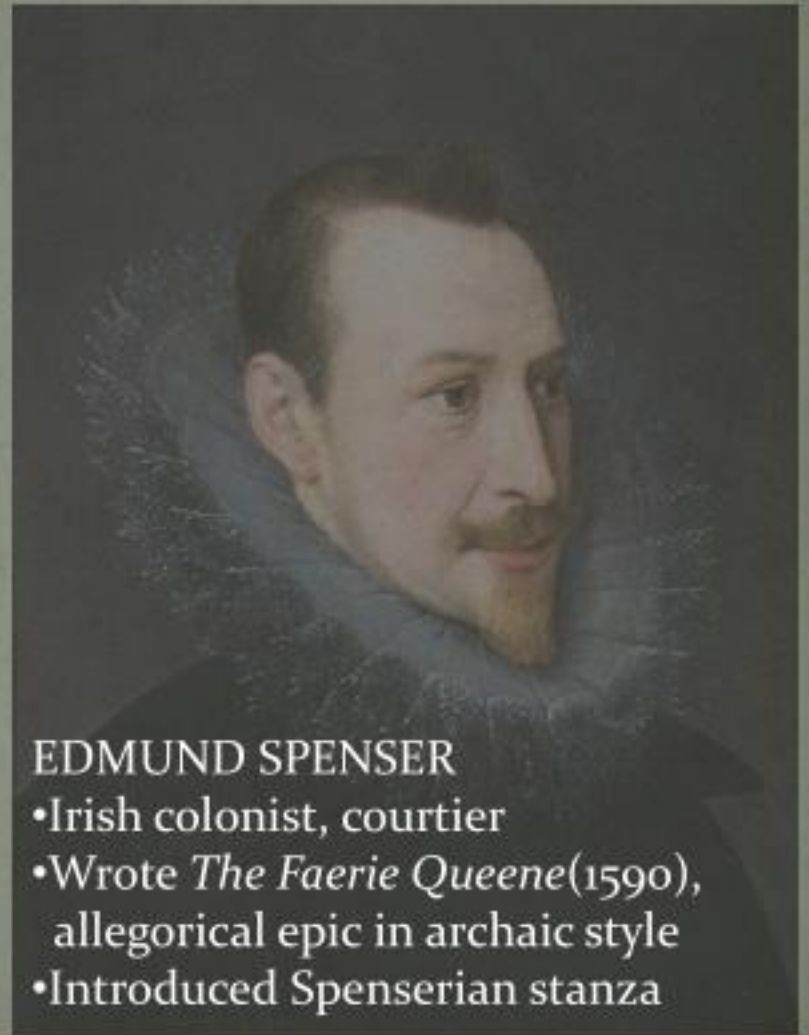

EDMUND SPENSER

- Irish colonist, courtier
- Wrote *The Faerie Queene* (1590), allegorical epic in archaic style
- Introduced Spenserian stanza

TIES TO ELIZABETH:

- **Gloriana**, the Faerie Queene, represents Elizabeth
- **Archimago**, an evil magician, represents the Church
- Symbolic implication of Gloriana's descent from **Arthur**

OVERALL MESSAGE:

- Humans are naturally inclined toward **good**,
- **Weak** when confronted with **temptation**, especially deception
- Only the **steadfastly virtuous** ultimately prevail

The Faerie Queene

ALLEGORICAL SIGNIFICANCE

The *Faerie* Queene

Britomart

Represents **Chastity**
Female knight
Moderation as key to salvation

Represents **Holiness**
Resembles **Peter**
Salvation through **suffering**
and **redemption**

Redcrosse

Artegal

Represents **Justice**
Defeats, then falls for, **Britomart**
Justice can be **virtue or weapon**

MAJOR
CHARACTERS

DANGEROUS DRAMATISTS

- Talented young **playwright** and poet
- Inventor of **blank verse**
- Best known for **ambitious** protagonists
- Worked as a **spy** in Walsingham's network
- Connected to "**School of Night**"
- Died at a young age, **knifed** in tavern brawl
- Shakespeare's greatest **rival**

Christopher Marlowe

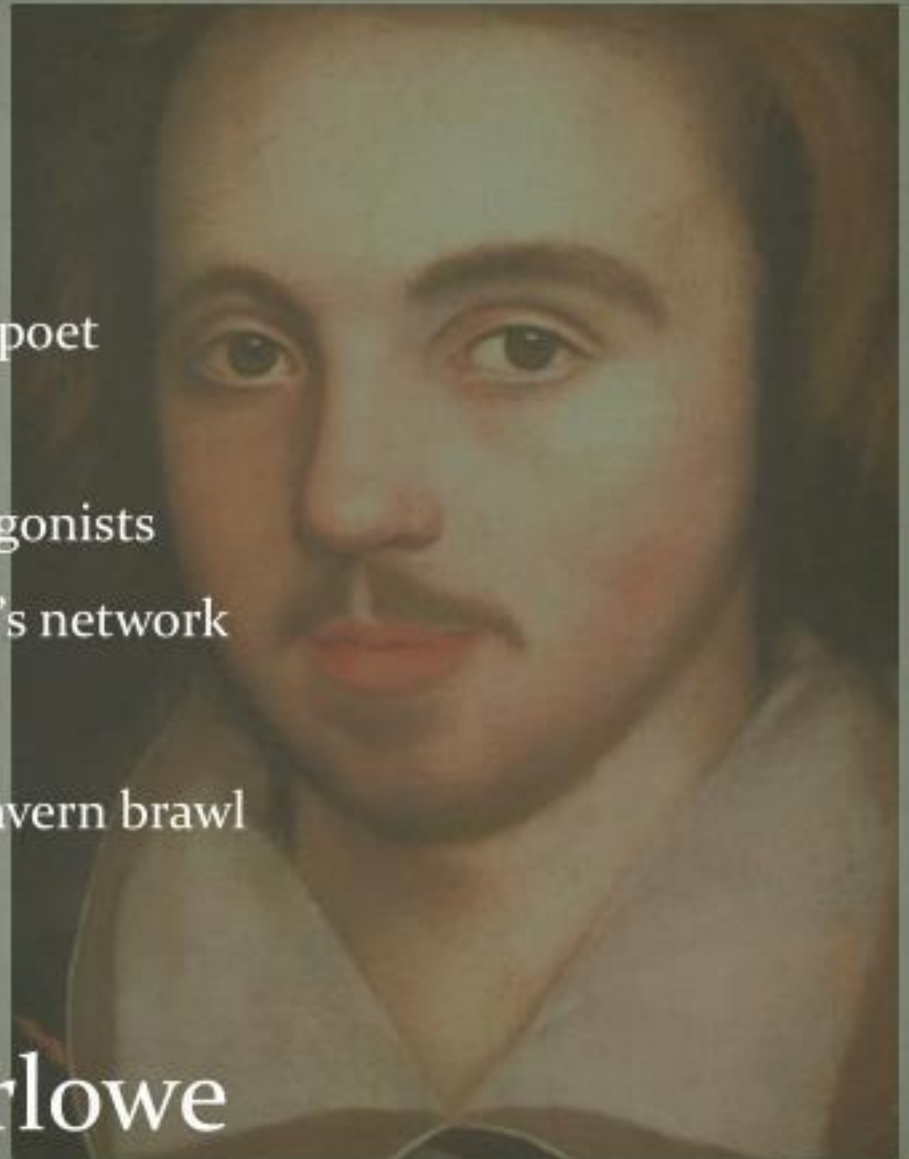

DANGEROUS DRAMATISTS

- Wrote **masques** and poetry as well as plays
 - Gift for comedy, especially **satire**
- Somewhat successful, but **temperamental**
- Killed a man in a duel, spent time in **prison**
 - **Popularity declined** as his plays aged
- *Volpone* and *The Alchemist* continue to win praise for **plotting and ingenuity**

Ben **Jonson**

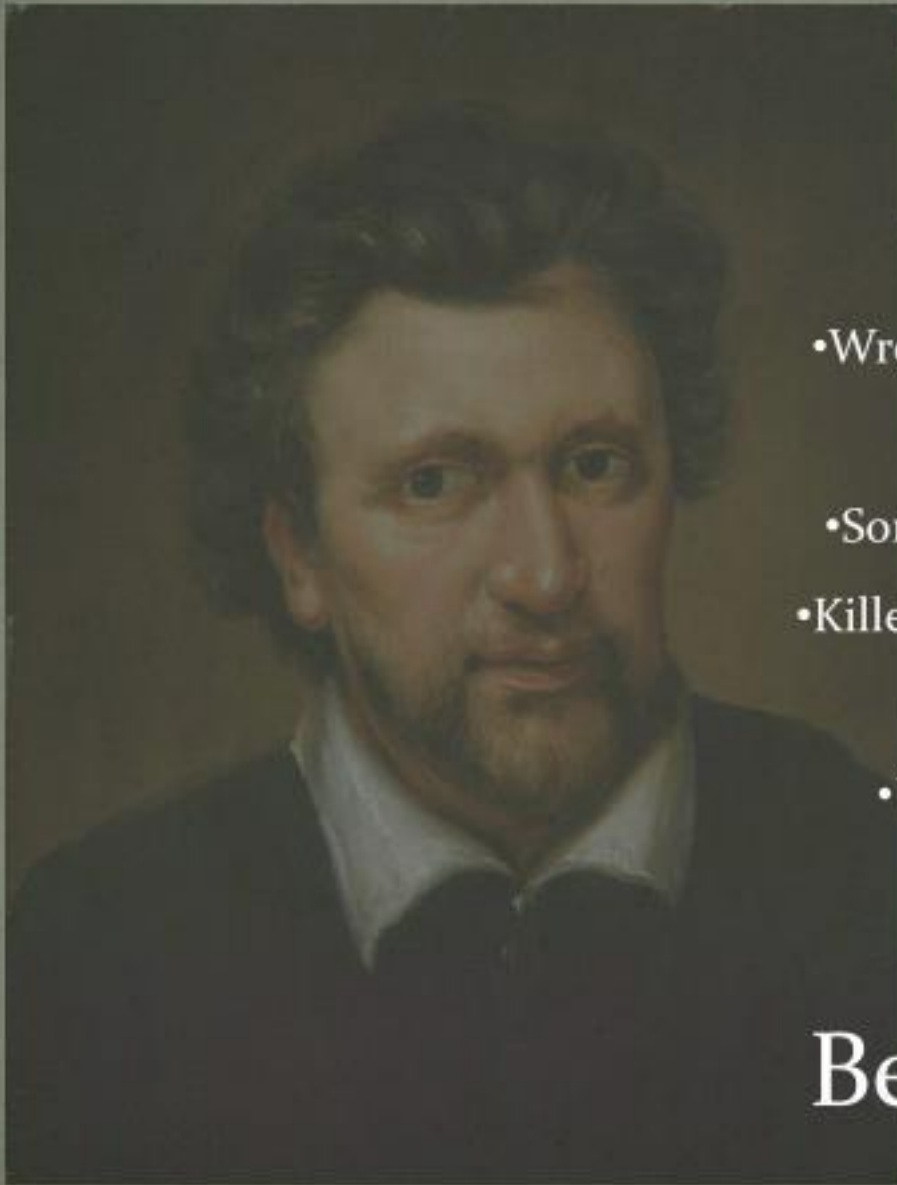

- Allegorical **fable** that satirizes greed
- Characters' names indicate **personalities**
- Best known for **ambitious** protagonists
- **Plot** is typical of Jonson:
 - Complex and convoluted, and ultimately instructive.
- Use of **grotesque** and varied **meter**

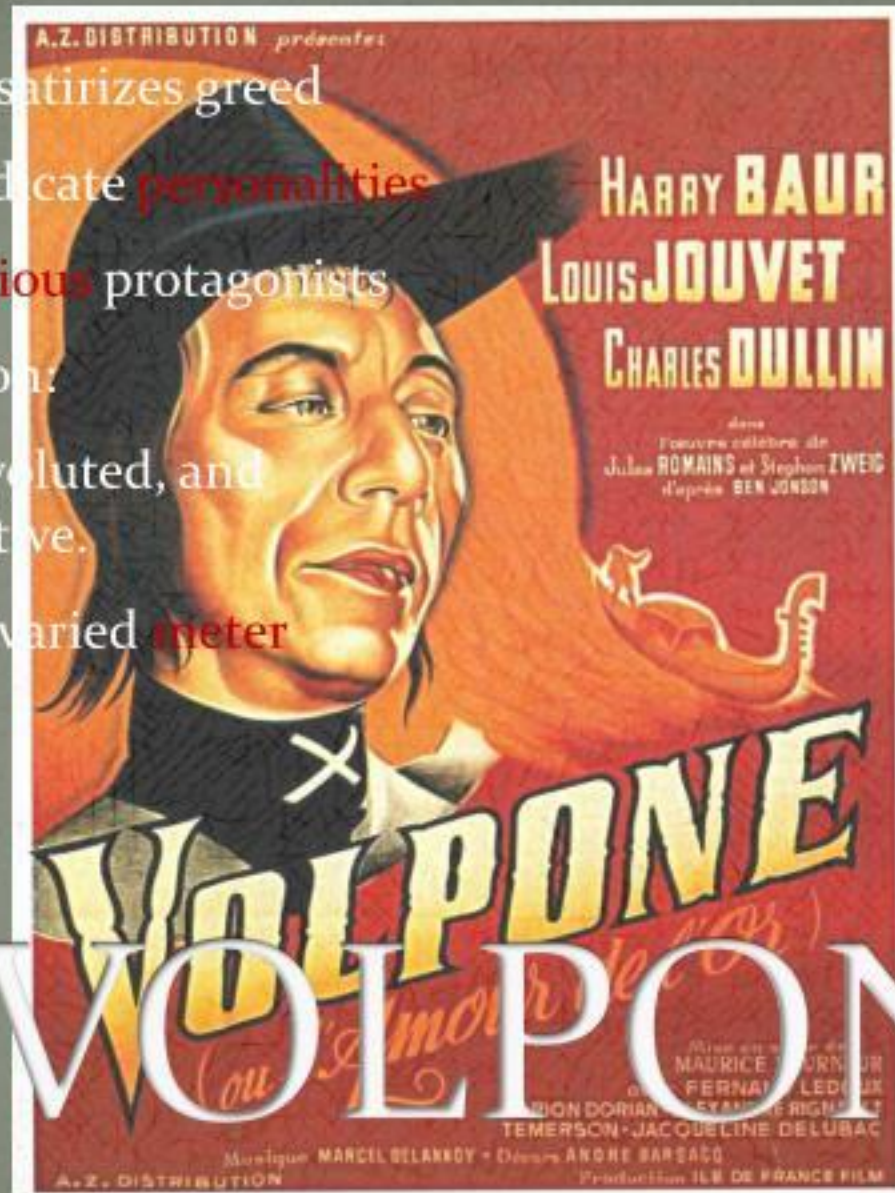

WOLFPONE

SCIENCE

AND

THE

SOUL

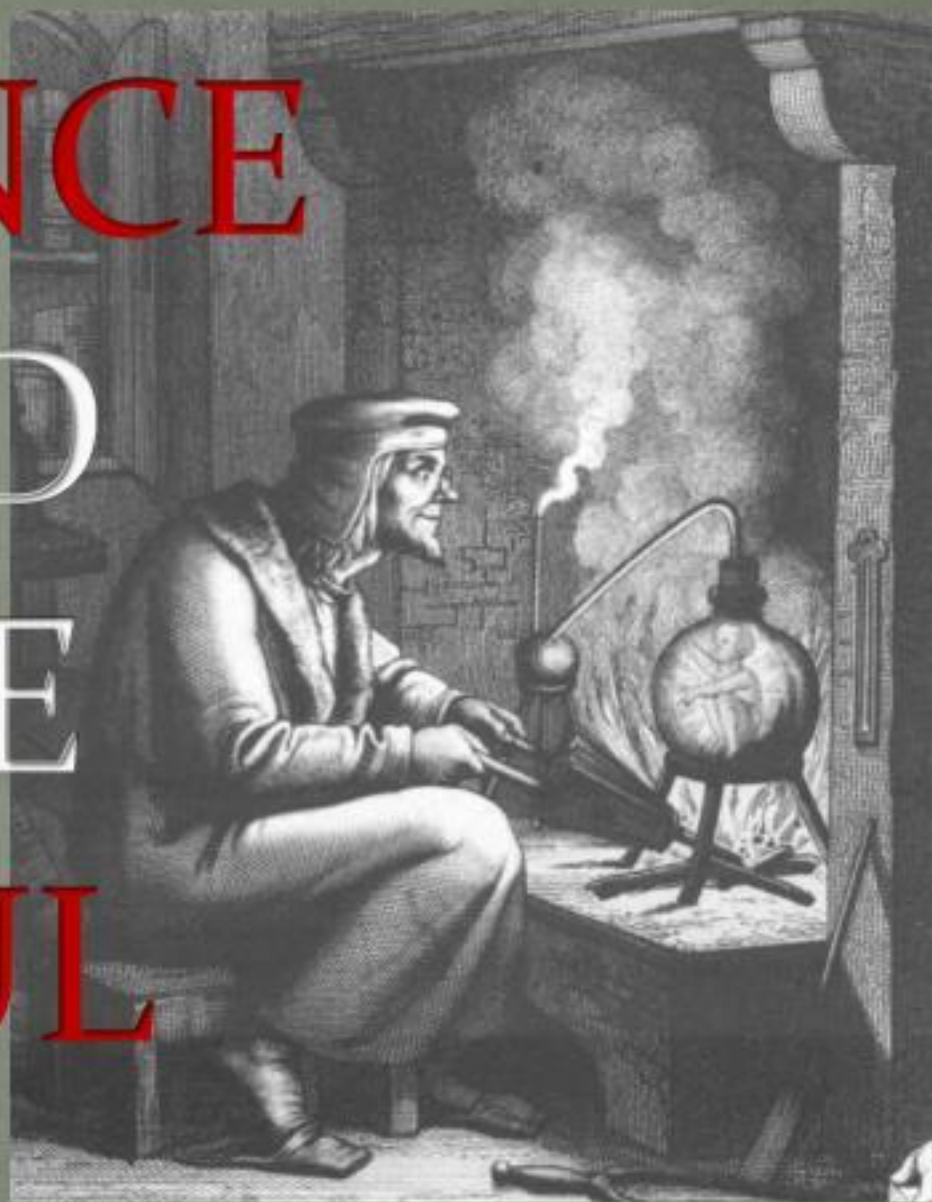

When we assume...



- **Faulty** assumptions lead to **incorrect** ideas
 - Four humors and human behavior
 - Homunculus and reproduction
- **Deductive** vs. **Inductive** Reasoning
- Development of the **scientific** method

Formation of Syllogism...

Proposition → Idea → Syllogism

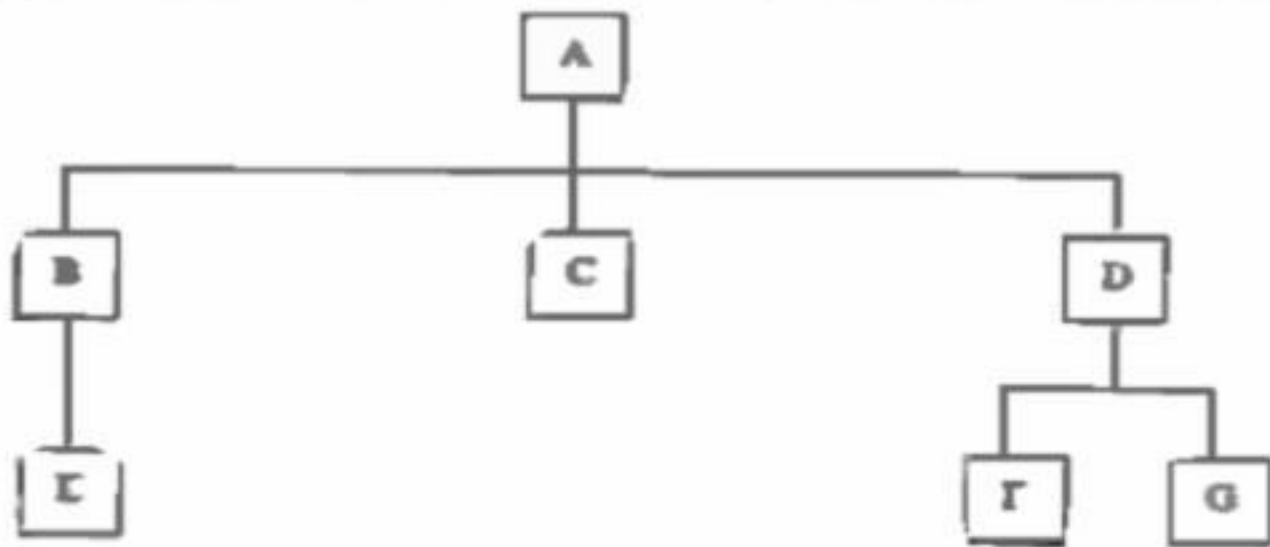

Prodigal Poets...

- **Soldier/politician** as a young man, became a **priest** late in life
- **Unconventional** life and style
- Often sacrifices elevated style for **discordancy** (for effect)
- Remembered for his poetry, but also his **conflict of faith**.

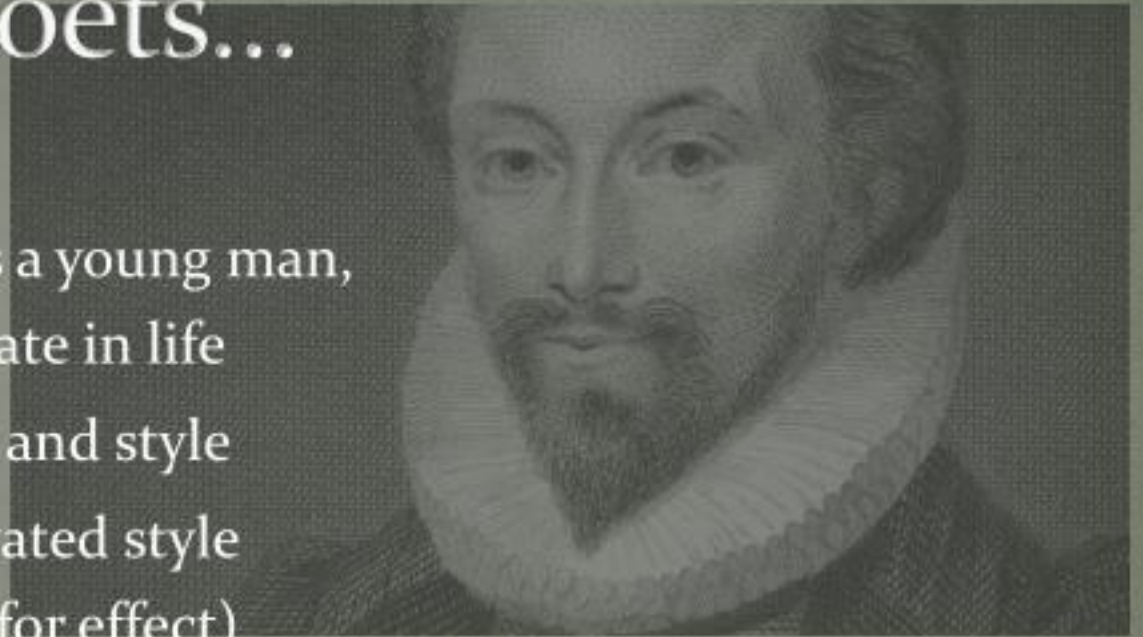

John Donne

Prodigal Poets...



- Soldier and politician as a young man, became a priest late in life
- Unconventional life and style
- Often sacrifices elevated style for discordancy (for effect)
- Remembered for his poetry, but also his conflict of faith, which reflects the period

John Milton