

Государственное бюджетное общеобразовательное учреждение
«Нижекамская школа №18 для детей
с ограниченными возможностями здоровья»

Урок швейного дела
«Соединение боковых срезов пижамной сорочки
запошивочным швом»

учитель труда
Гаева С.Б.

Пословица

«Труд человека кормит, а
лень портит»



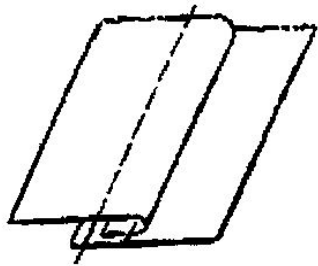

1

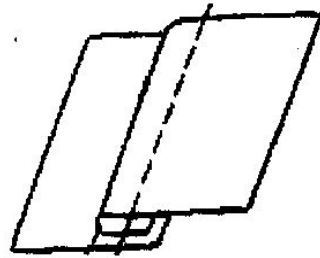

2

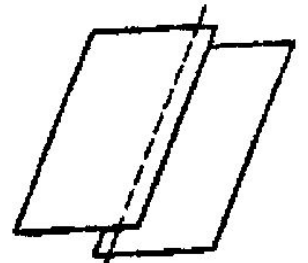

3

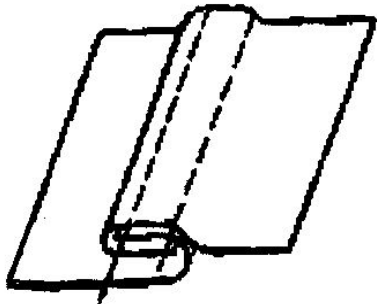

4

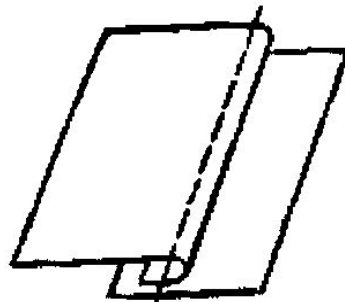

5

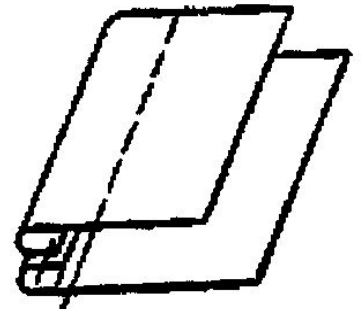

6

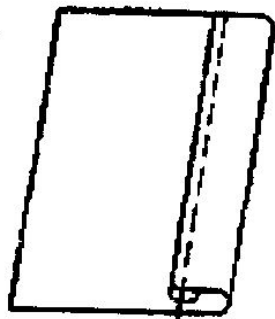

7

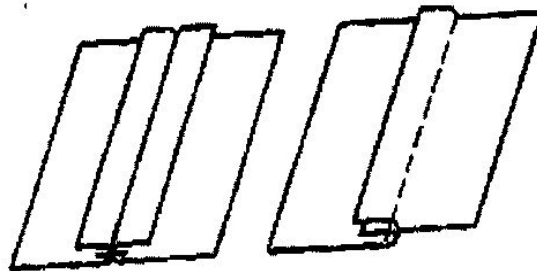

8

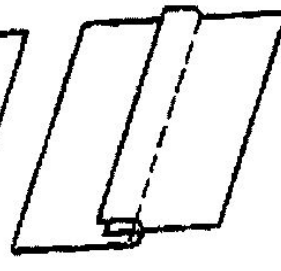

9

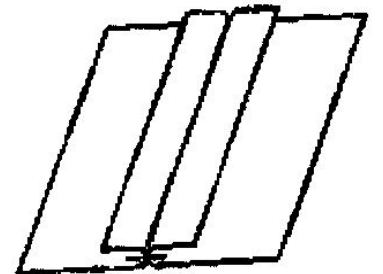

10

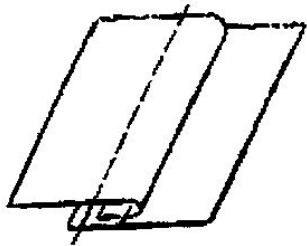

1

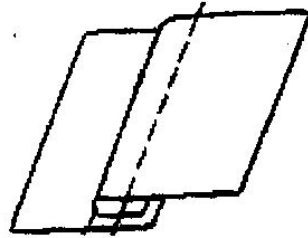

2

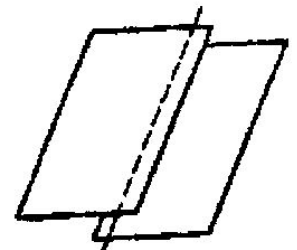

3

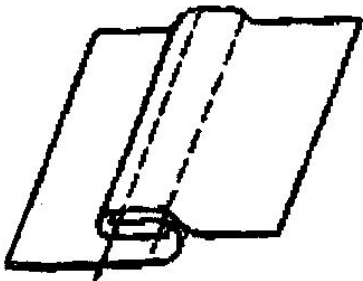

4

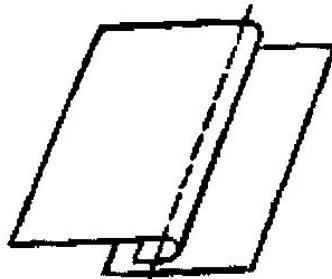

5

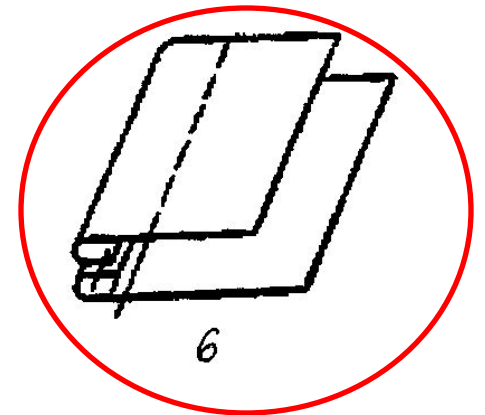

6

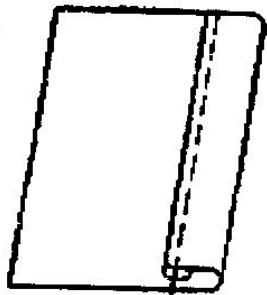

7

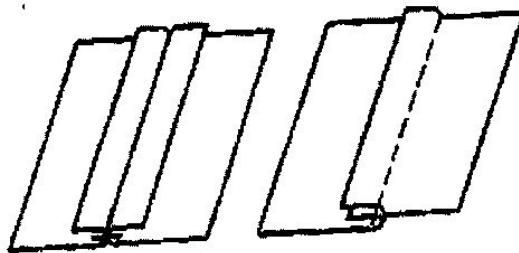

8

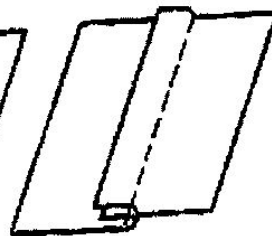

9

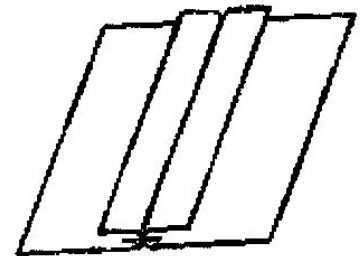

10

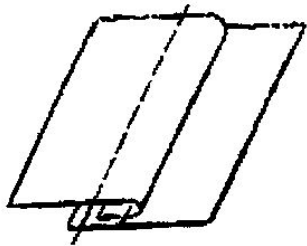

1

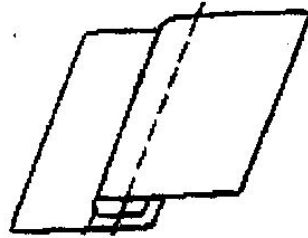

2

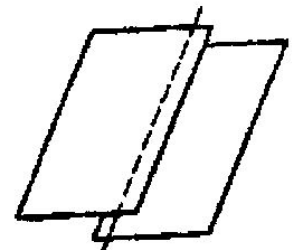

3

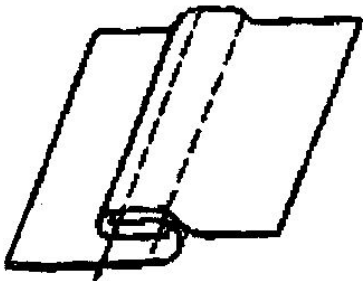

4

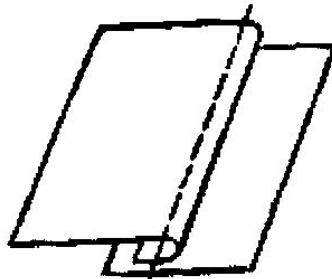

5

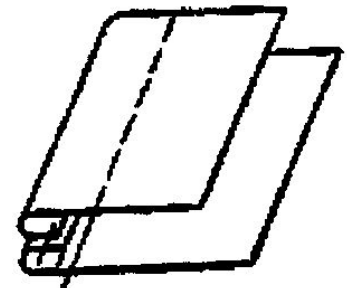

6

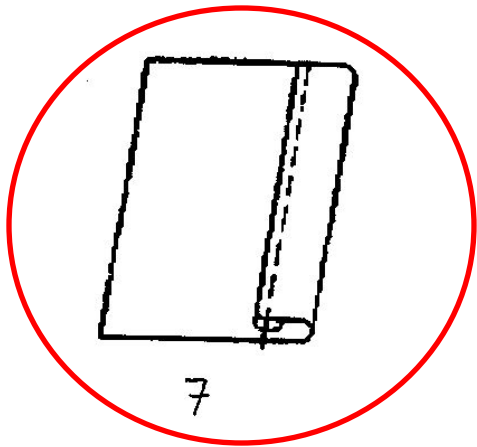

7

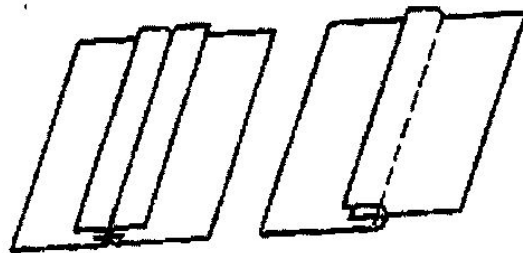

8

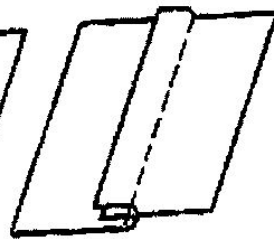

9

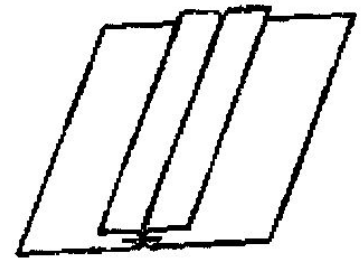

10

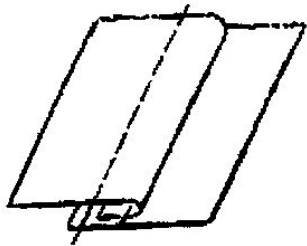

1

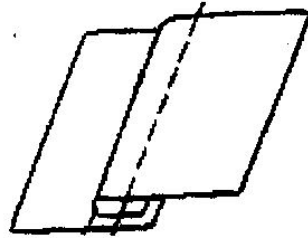

2

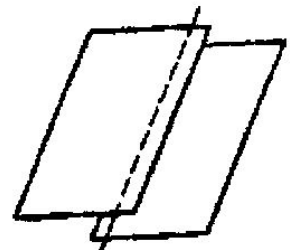

3

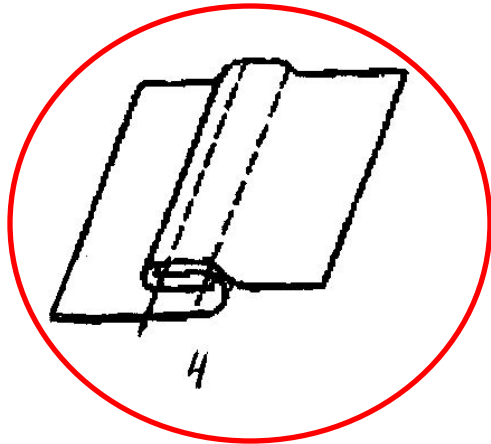

4

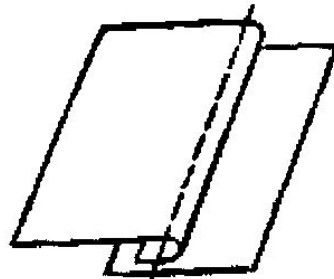

5

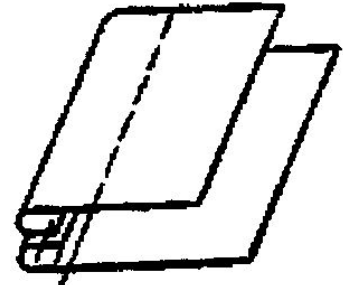

6

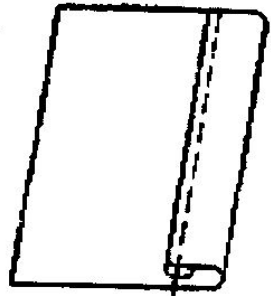

7

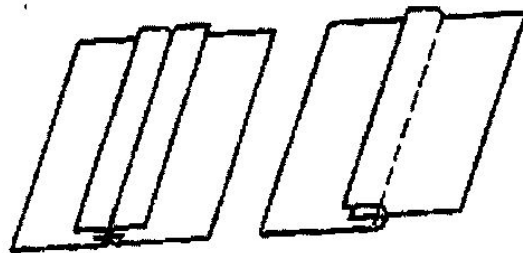

8

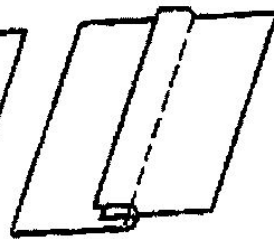

9

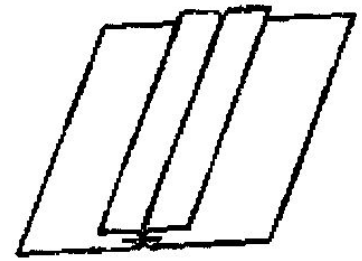

10

Словарные слова

ПИЖА́МА

БО́КОВОЙ СРЕ́З

ЗАПО́ШИВОЧНЫЙ ШОВ



Запошивочный шов

Физминутка

Чтобы сильной стать и ловкой,
Приступаем к тренировке.
Носом вдох, а выдох ртом.
Дышим глубже, а потом,
Шаг на месте, не спеша.
Как погода - хороша!
Мы проверили осанку,
И свели лопатки.
Мы походим на носках,
А потом на пятках.



Какие инструменты необходимы для пошива пижамы?

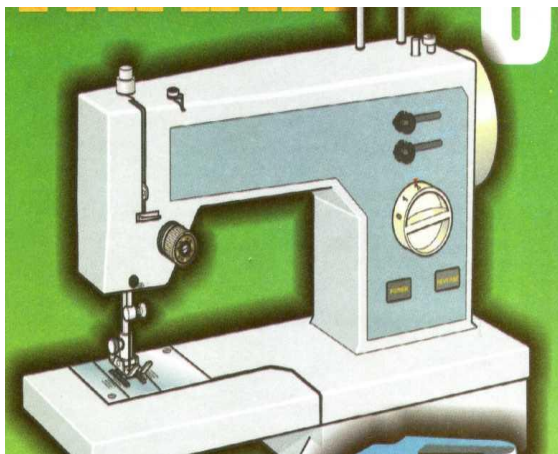
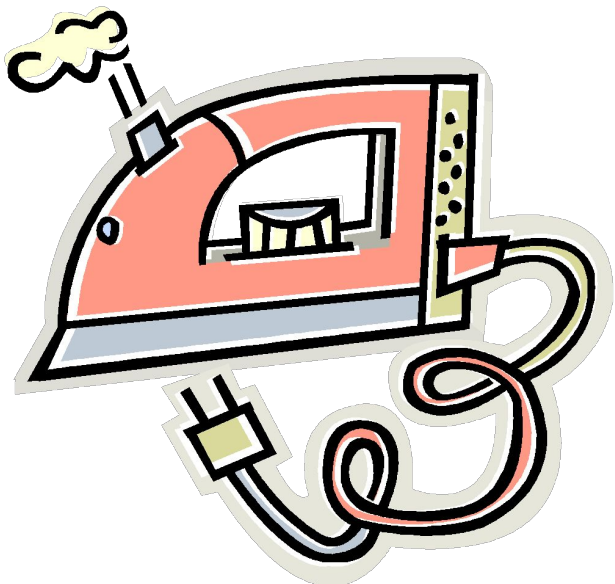

Практическая работа

**Обработка боковых срезов
пижамной сорочки
запошивочным швом**

Технологическая карта

7-9 мм

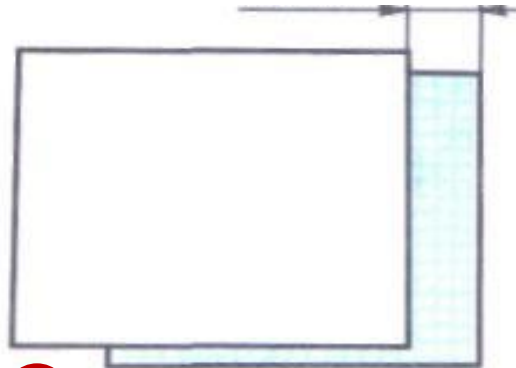

①

5-7 мм

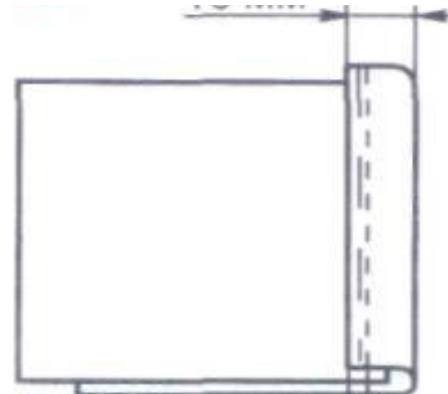

②

2-3 мм

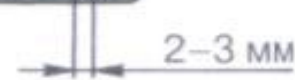

1-2 мм

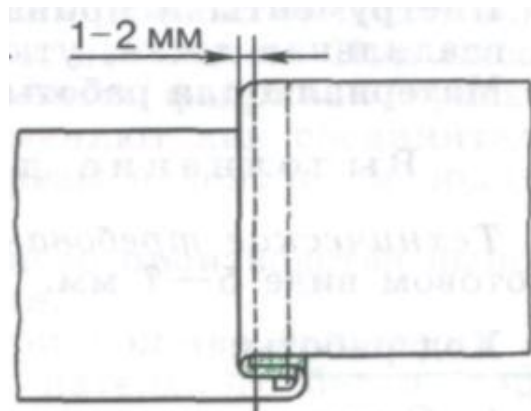

③

④

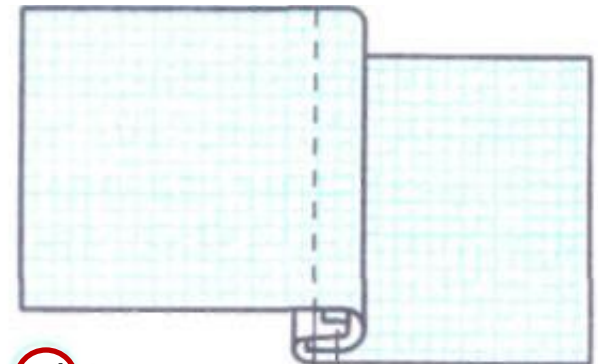



Технологическая карта

7-9 мм

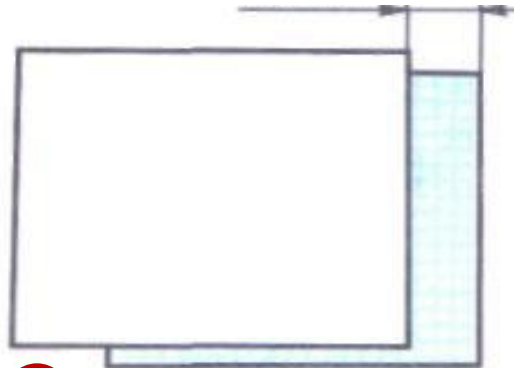

①

5-7 мм

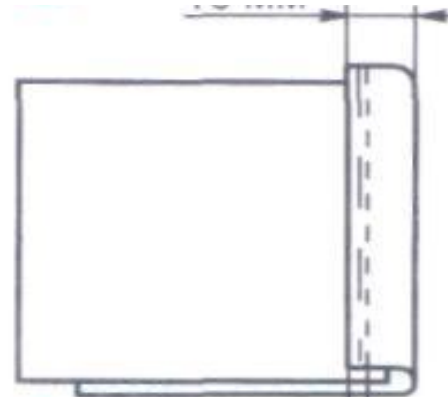

②

2-3 мм

1-2 мм

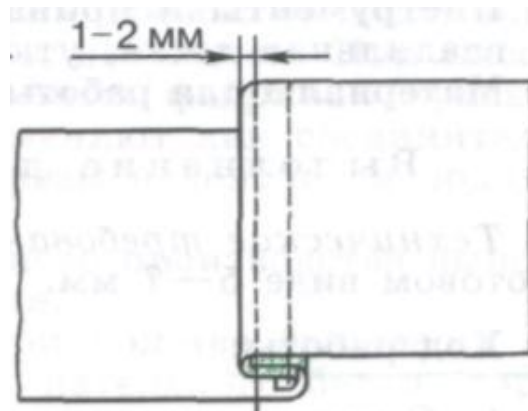

③

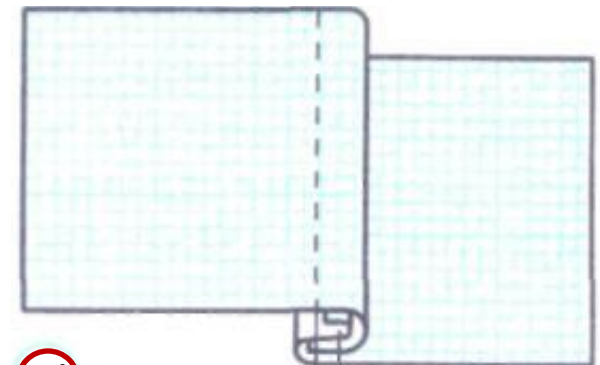

④

Проверка качества работы

1. Ширина шва равна 7мм.
2. Строчка ровная, проложена точно по краю подгиба.
3. На лицевой стороне нет слабину ткани в шве.
4. Шов хорошо приутюжен.

Спасибо за работу