

# КЛАССИФИКАЦИЯ ЛЕТАТЕЛЬНЫХ АППАРАТОВ

# Типы классификации

## ОБЩИЕ ПРИЗНАКИ

Гражданские

Пассажирские

Транспортные

Военные



**Военные**

**Истребители**



# ЧАСТНЫЕ ПРИЗНАКИ

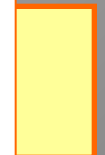
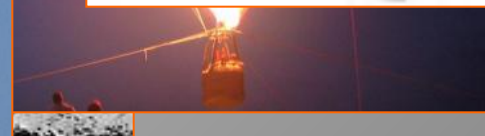
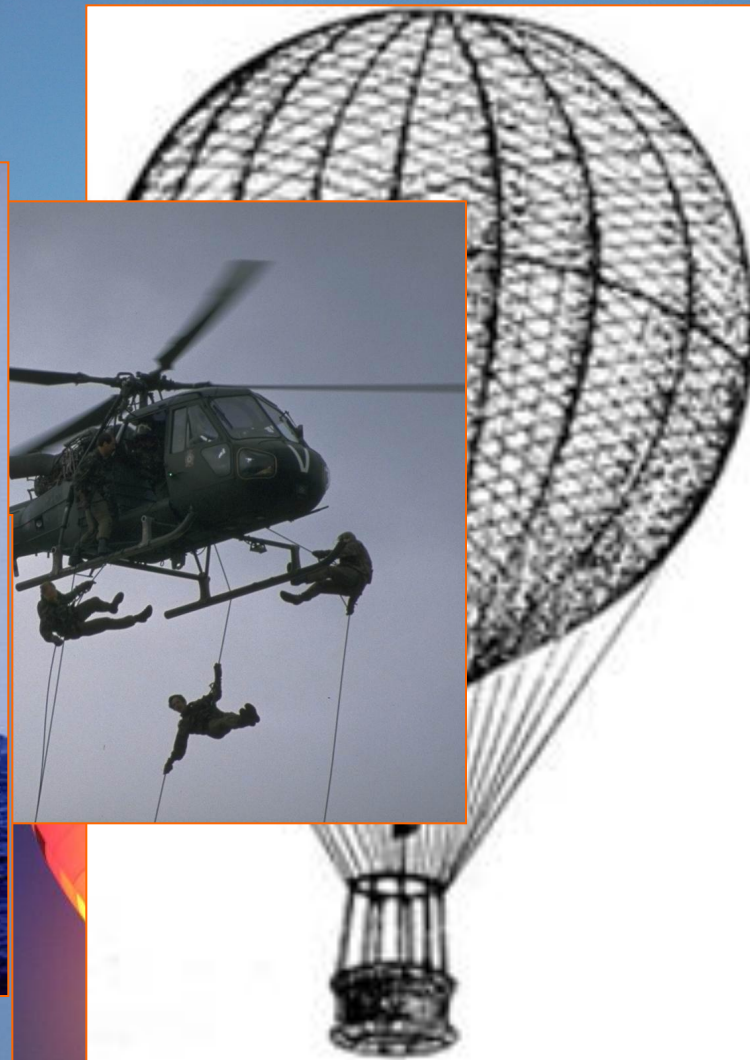

# УЗКИЕ ПРИЗНАКИ

Аэродинамическая  
схема

Число и  
расположени  
е

Крыло

Форма  
в плане

Схема оперения

Расположени  
е

Схема шасси

Тип опорного  
элемента

Схема фюзеляжа

Расположени  
е

Силовая установка

Тип  
двигателя

Скорость

Взлетная масса

Маневренность

# СИЛОВАЯ УСТАНОВКА

Тип двигателя

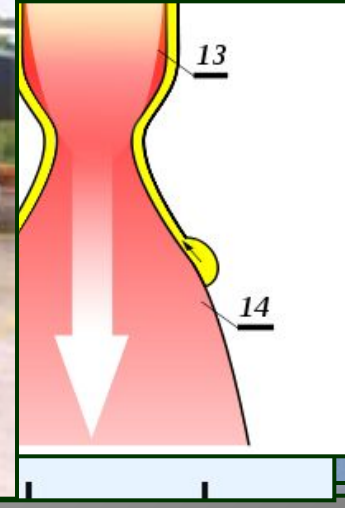
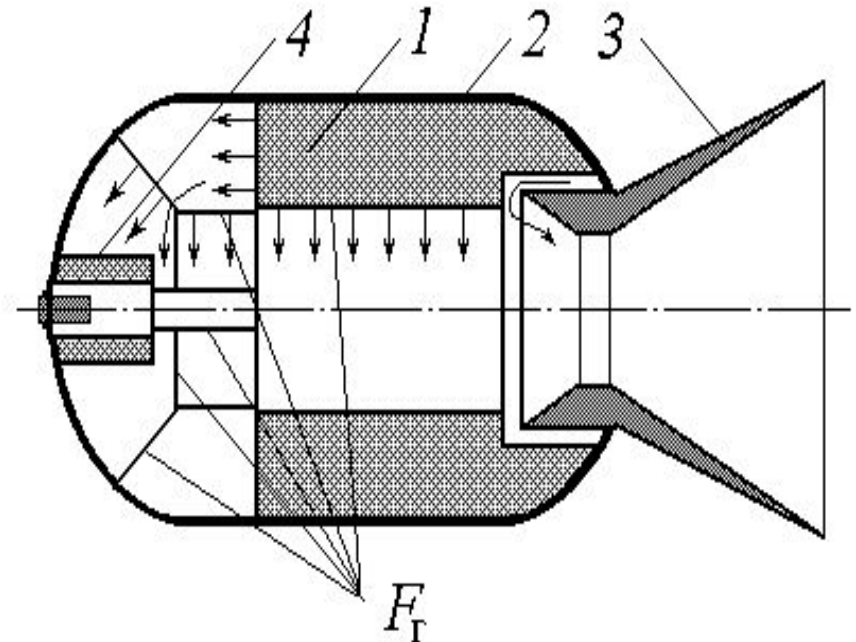
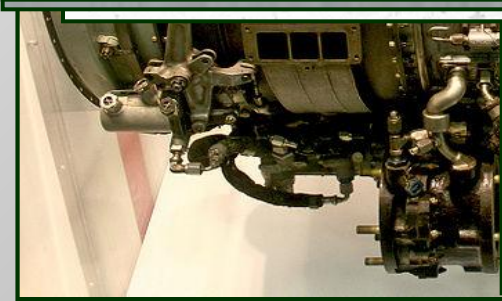

# АЭРОДИНАМИЧЕСКАЯ СХЕМА

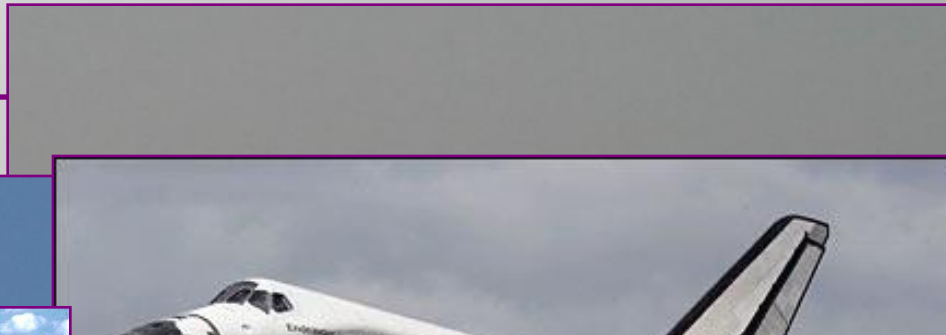

# СХЕМА ФЮЗЕЛЯЖА

Нормальная

