

NIKOLA TESLA

10 July 1856 – 7 January 1943

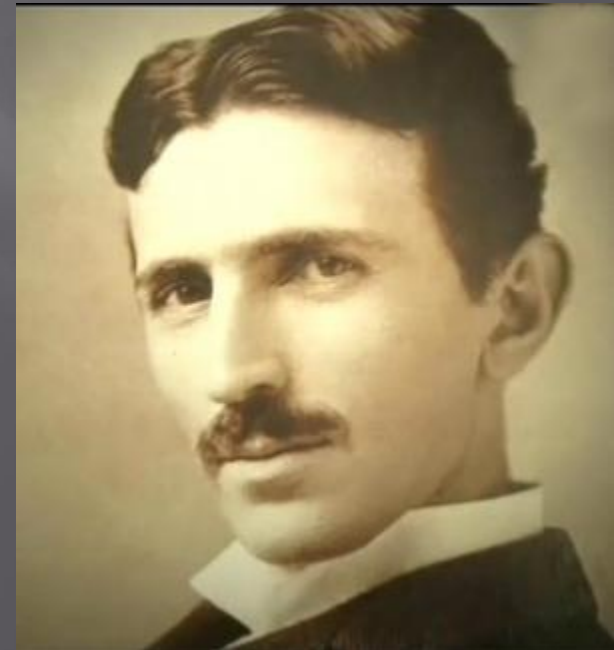

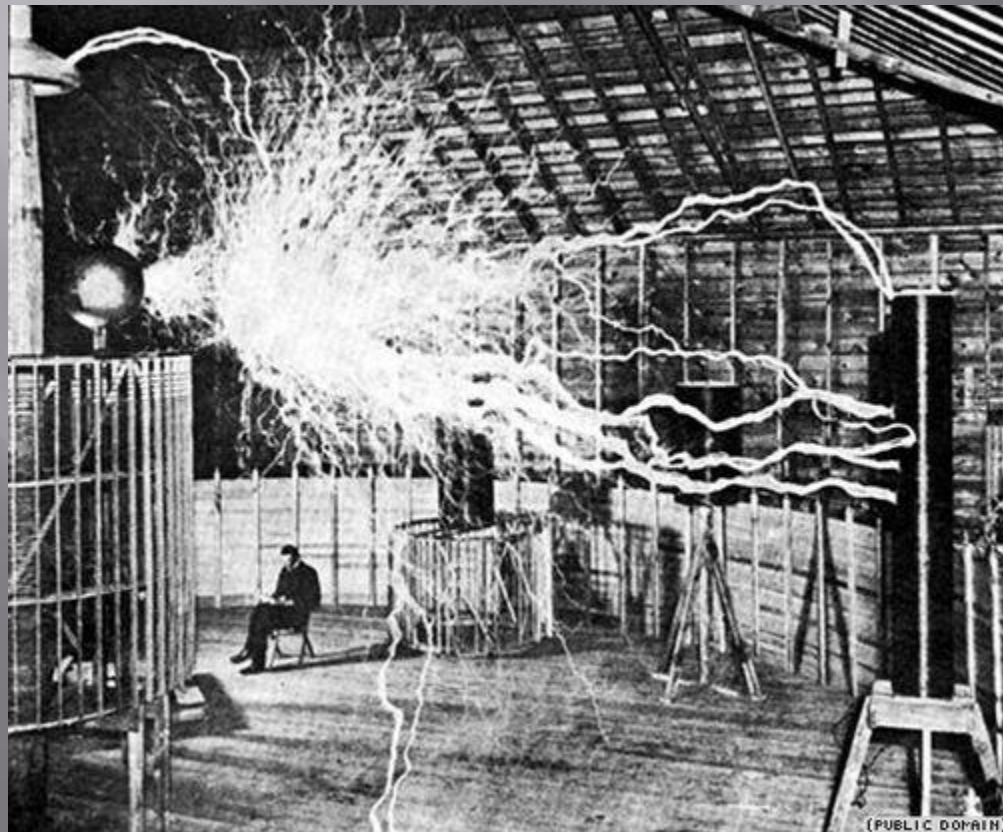

- Tesla was born to Serbian parents in the Croatian village of Smiljan near Gospić, in the Lika region of the Austrian-Hungarian Empire. According to legend, he was born precisely at midnight during an electrical storm.
- His baptismal certificate reports that he was born on 28 June (N.S. 10 July), 1856, and christened by the Serbian Orthodox priest Toma Oklobdžija. His father was Father Milutin Tesla, a priest in the Serbian Orthodox Church Metropolitanate of Sremski Karlovci. Milutin was born on 19 February 1819 in the village of Raduc, county Medak in Lika, Austrian Empire, as son of Nikola Tesla (b. 1789 in the military frontier, settled after his service in the Napoleonic Wars in Gospić in 1815) and Ana Kalinić, from the famous frontier Kalinic family. Tesla's family asserted its last name as such in Lika. Tesla then studied electrical engineering at the Austrian Polytechnic in Graz (1875). While there, he studied the uses of alternating current. Some sources say he received Baccalaureate degrees from the university at Graz. However, the university says that he did not receive a degree and did not continue beyond the first semester of his third year, during which he stopped attending lectures. In December 1878 he left Graz and broke all relations with his family. His friends thought that he had drowned in Mura. He went to Maribor, Slovenia, where he was first employed as an assistant engineer for a year. He suffered a nervous breakdown during this time. Tesla was later persuaded by his father to attend the Charles-Ferdinand University in Prague, which he attended for the summer term of 1880. Here he was influenced by Ernst Mach. However after his father died he left the university, having completed only one term.

- ▣ In 1880, he moved to Budapest, Hungary, to work under Tivadar Puskás in a telegraph company, the National Telephone Company. There, he met Nebojša Petrović, a young, Serbian inventor who lived in Austria. Although their encounter was brief, they did work on a project together using twin turbines to create continual power. On the opening of the telephone exchange in Budapest, 1881, Tesla became the chief electrician to the company, and was later engineer for the country's first telephone system. He also developed a device that, according to some, was a telephone repeater or amplifier, but according to others could have been the first loudspeaker. In 1882 he moved to Paris, France, to work as an engineer for the Continental Edison Company, designing improvements to electric equipment. In the same year, Tesla conceived the induction motor and began developing various devices that use rotating magnetic fields for which he received patents in 1888.



- ▣ Young Nikola Tesla came to the United States in 1884 with an introduction letter from Charles Batchelor to Thomas Edison: “I know two great men,” wrote Batchelor, “one is you and the other is this young man.” Tesla spent the next 59 years of his productive life living in New York. And there, in USA he made his greatest invention. For example his Electromechanical devices and principal developed by Nikola Tesla:

TURBINE

ELECTRIC INCANDESCENT LAMP

SYSTEM OF ELECTRIC LIGHTING

METHOD OF SIGNALING

ELECTED MAGNETIC MOTOR

METHOD OF INSULATING ELECTRIC CONDUCTORS

MEANS FOR INCREASING THE INTENSITY OF ELECTRICAL OSCILLATIONS

APPARATUS FOR THE UTILIZATION OF RADIANT ENERGY

APPARATUS FOR TRANSMISSION OF ELECTRICAL ENERGY

SPEED INDICATOR

ELECTRIC CIRCUIT CONTROLLER

1,061,206.

Patented May 6, 1913.

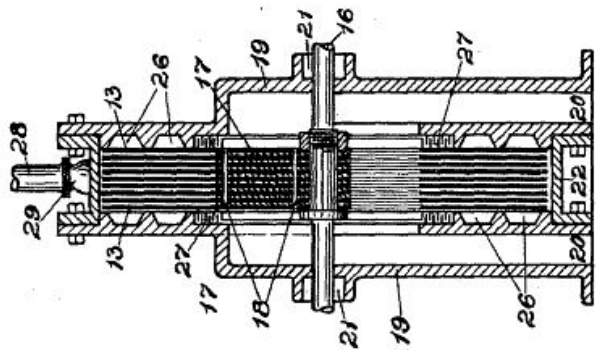

Fig. 2.

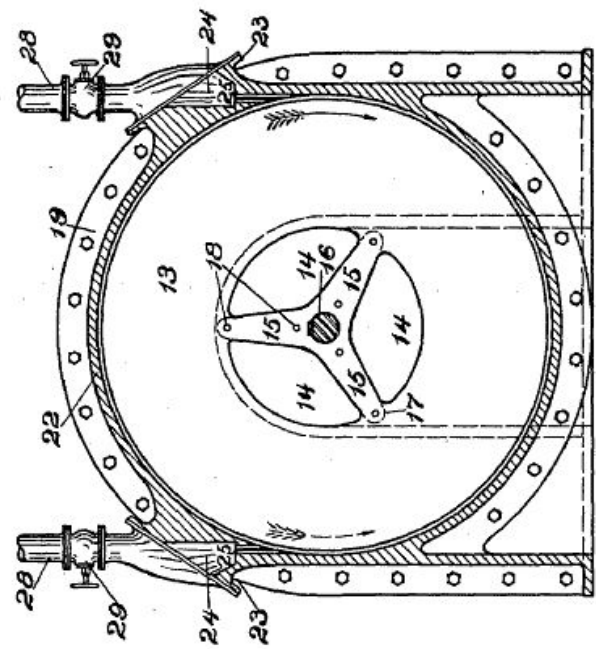

Fig. 1.

Witnesses:
A. Diaz Quintana
Wm. Kohler

Nikola Tesla, Inventor
By his Attorneys,
Newberg, Cooper & Hayward



(No Model.)

N. TESLA.
ELECTRIC INCANDESCENT LAMP.

No. 455,069.

Patented June 30, 1891.

Fig. 1

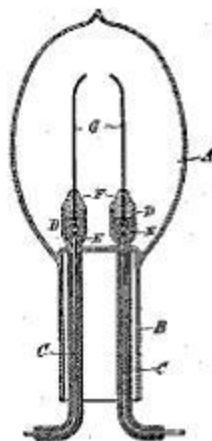
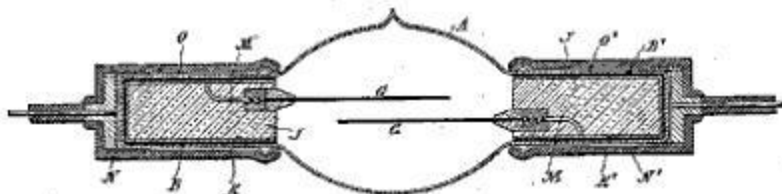

Fig. 2



Witnesses:
Raphael Water
Frank B. Murphy.

Inventor
Nikola Tesla
by
Duncan & Sage
Attorneys.



(No Model.)

N. TESLA.
SYSTEM OF ELECTRIC LIGHTING.

No. 454,622.

Patented June 23, 1891.

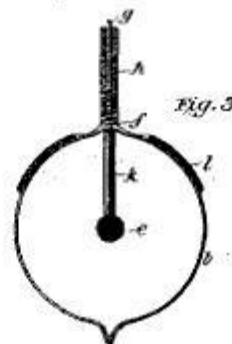
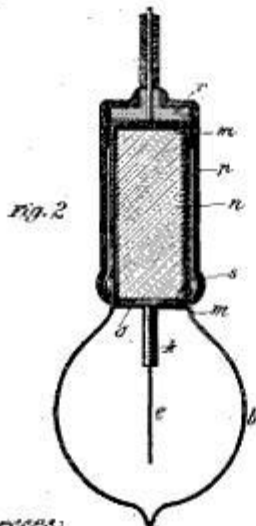
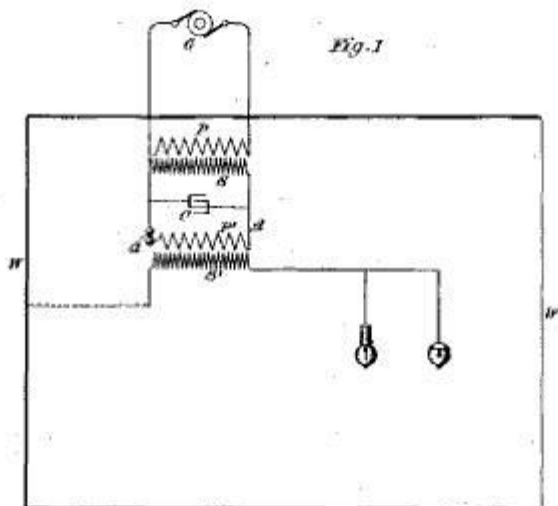

Witnesses:
Raphael Peter
Gustaf Lofgrenson

Inventor
Nikola Tesla
by
Duncan & Page,
Attorneys.



N. TESLA.
METHOD OF SIGNALING.
APPLICATION FILED JUNE 14, 1901.

NO MODEL.

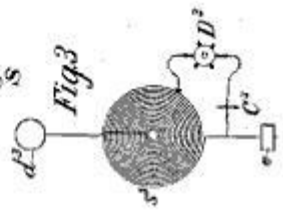
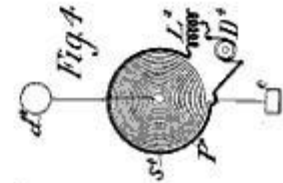
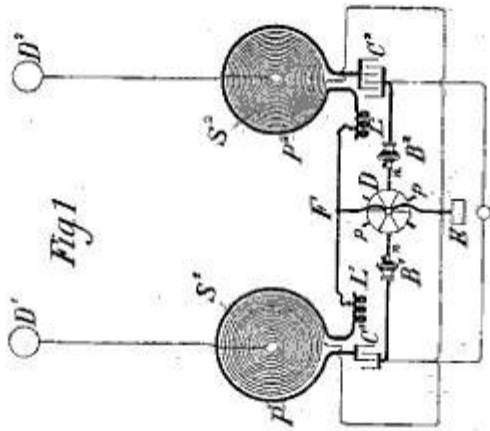
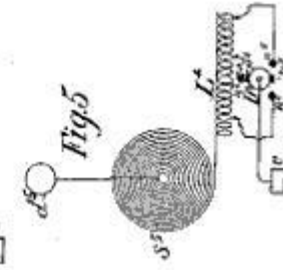
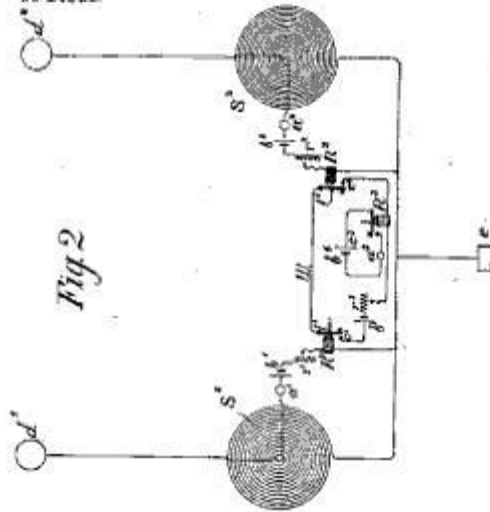

WITNESSES:
Beyamin Miller,
Richard H. ...

INVENTOR.
Nikola Tesla
 BY
Ken. Page & Cooper,
 ATTORNEYS.



N. TESLA.

METHOD OF INSULATING ELECTRIC CONDUCTORS.

(Application filed June 15, 1900.)

(No Model.)

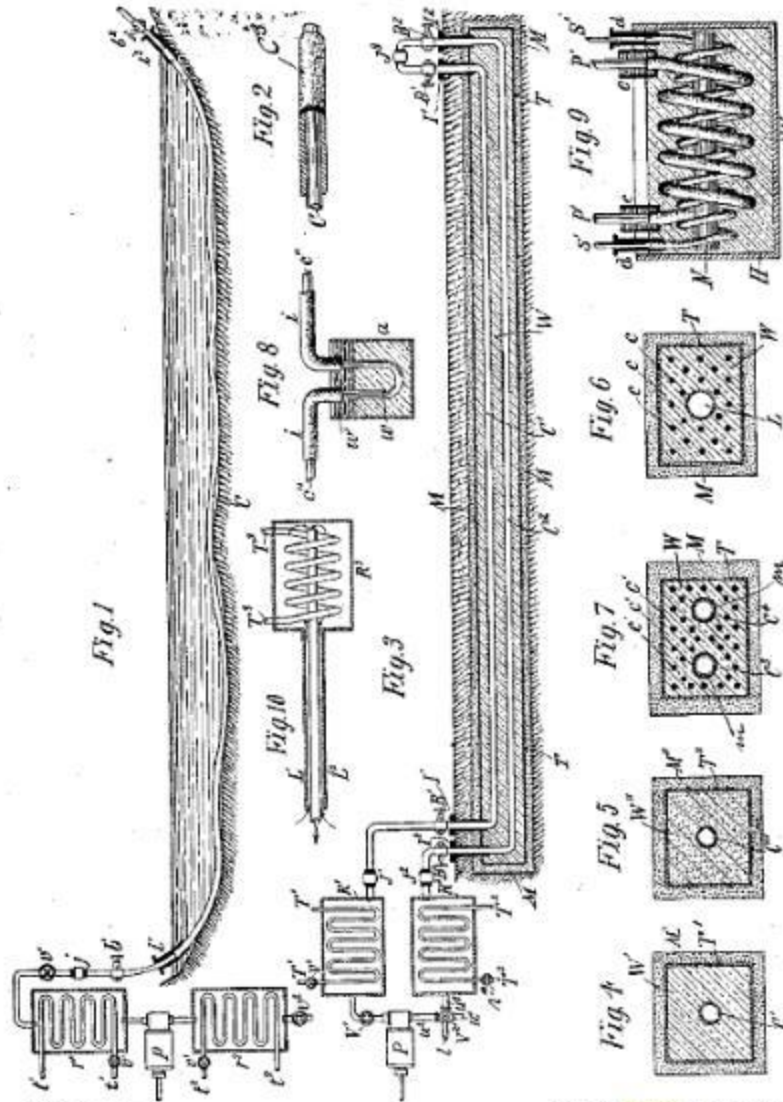

Witnesses:

Raphael Ketler
G.D. Merrill

Nikola Tesla, Inventor

by Kerr, Page & Cooper,
Attys



No. 685,012.

Patented Oct. 22, 1901.

N. TESLA.

MEANS FOR INCREASING THE INTENSITY OF ELECTRICAL OSCILLATIONS.

(Application filed Mar. 21, 1900. Renewed July 6, 1901.)

(No Model.)

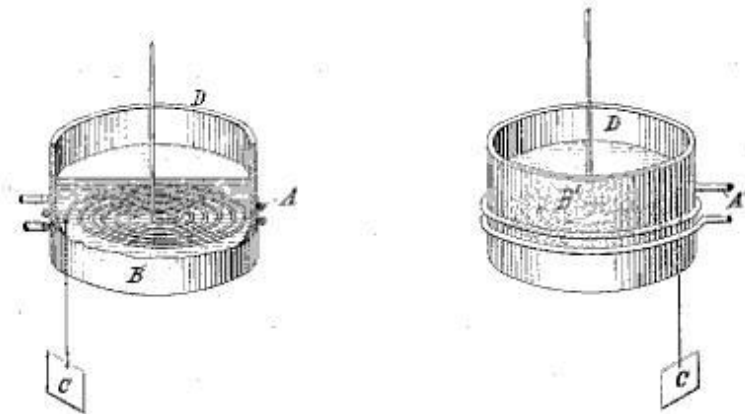

Witnesses:
Kopkail Ketter
Benjamin Miller.

Nikola Tesla, Inventor
by *Herbert A. Harper* Atty.



N. TESLA.

APPARATUS FOR THE UTILIZATION OF RADIANT ENERGY.

(Application filed Mar. 21, 1901.)

(No Model.)



Fig. 1

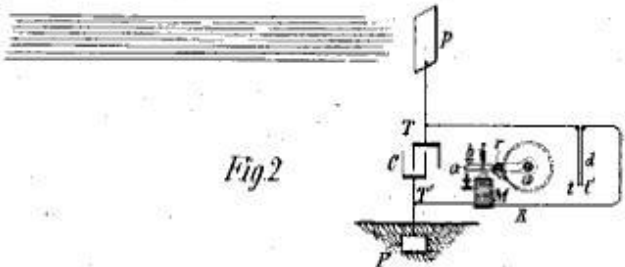

Fig. 2

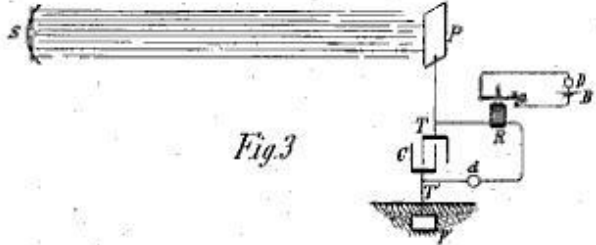

Fig. 3

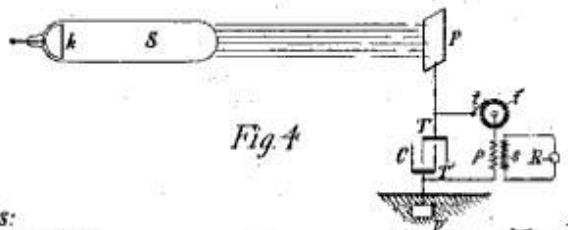

Fig. 4

Witnesses:
Rudolf Ritter
M. Lawrence Dyer

Inventor
Nikola Tesla
 by *Ken. Page & Cooper* Attys.



N. TESLA.

APPARATUS FOR TRANSMISSION OF ELECTRICAL ENERGY.

(Application filed Feb. 10, 1900.)

(No Model.)

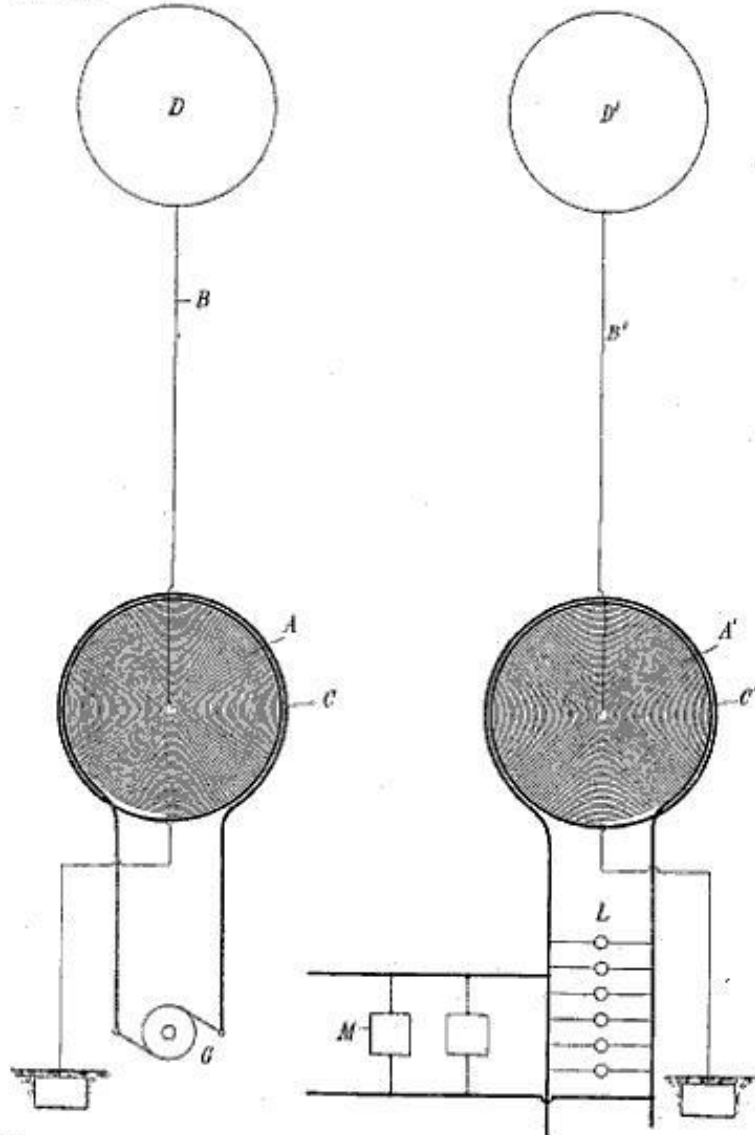

Witnesses:
Benjamin Miller.
G. W. Marling.

Nikola Tesla, Inventor
 by *Ken. Page & Co.*
 Attys



N. TESLA.
SPEED INDICATOR.
APPLICATION FILED MAY 29, 1914.

1,209,359.

Patented Dec. 19, 1916.

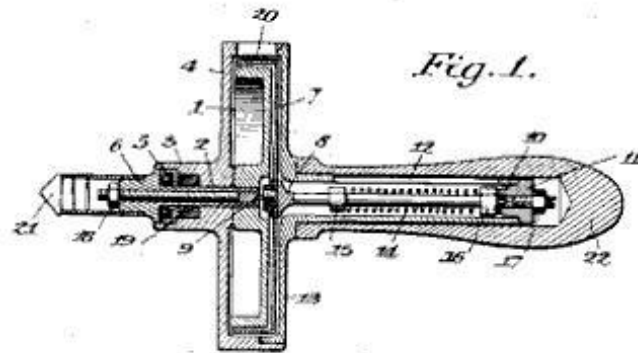

Fig. 1.

Fig. 3.

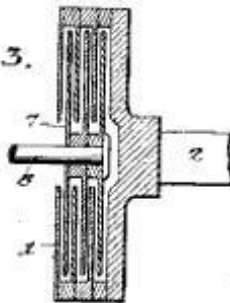

Fig. 4.

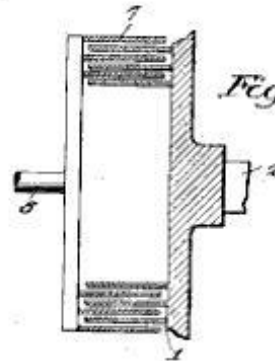
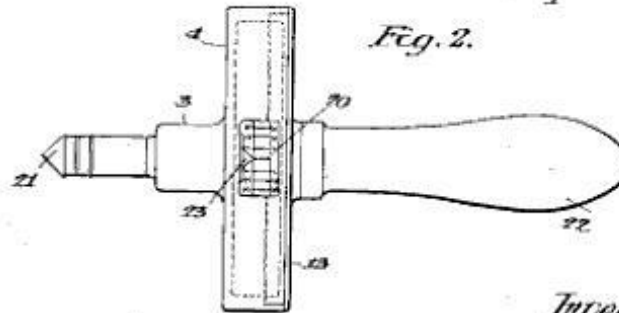

Fig. 2.



Inventor:
Nikola Tesla
Forie Rainalway,
Attorney



N. TESLA.
ELECTRICAL CIRCUIT CONTROLLER.

(Application filed Dec. 20, 1897.)

(No Model.)

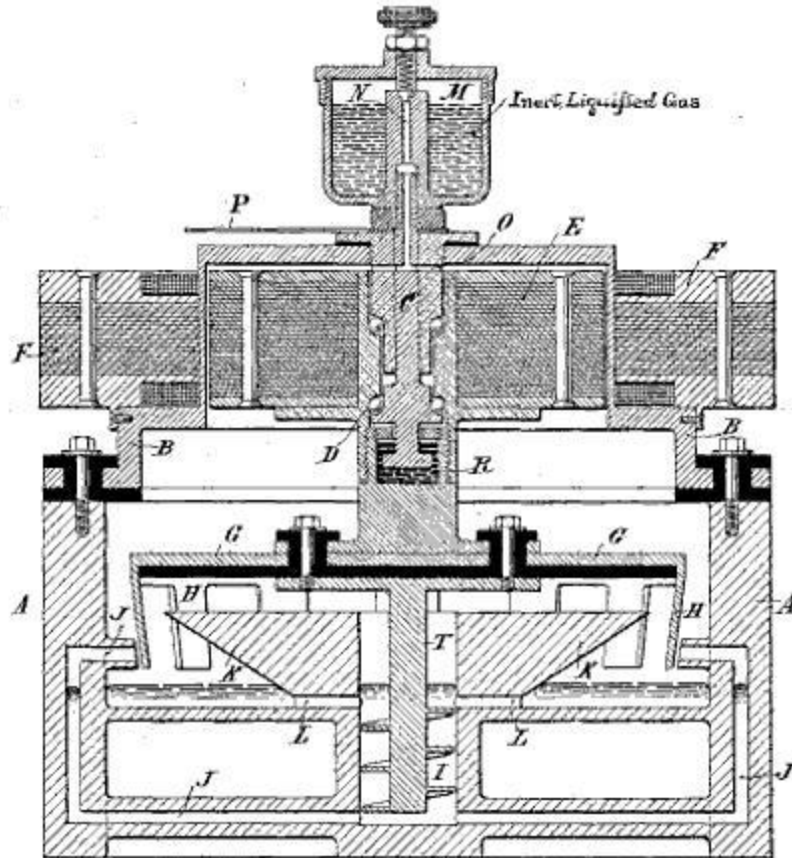

Witnesses:
Raphael Ketler
Edwin B. Hopkins.

Nikola Tesla, Inventor
by Kerr, Curtis & Page, Attys.



Tesla died on January 7th, 1943 in the Hotel New Yorker, where he had lived for the last ten years of his life. Room 3327 on the 33rd floor is the two-room suites he occupied.

A state funeral was held at St. John the Divine Cathedral in New York City. Telegrams of condolence were received from many notables, including the first lady Eleanor Roosevelt and Vice President Wallace. Over 2000 people attended, including several Nobel Laureates. He was cremated in Ardsley on the Hudson, New York. His ashes were interred in a golden sphere, Tesla's favorite shape, on permanent display at the Tesla Museum in Belgrade along with his death mask.

In his speech presenting Tesla with the Edison medal, Vice President Behrend of the Institute of Electrical Engineers eloquently expressed the following: "Were we to seize and eliminate from our industrial world the result of Mr. Tesla's work, the wheels of industry would cease to turn, our electric cars and trains would stop, our towns would be dark and our mills would be idle and dead. His name marks an epoch in the advance of electrical science." Mr. Behrend ended his speech with a paraphrase of Pope's lines on Newton: "Nature and nature's laws lay hid by night. God said 'Let Tesla be' and all was light."

“The world will wait a long time for Nikola Tesla’s equal in
achievement and imagination.” E. ARMSTRONG

Nikola Tesla’s Awards and Recognition