

***The Blending of Genres:  
Interaction of  
the University novel and the  
Industrial novel in David  
Lodge's «Nice Work»***



**VS**

**Academic  
World**

**Industrial World**

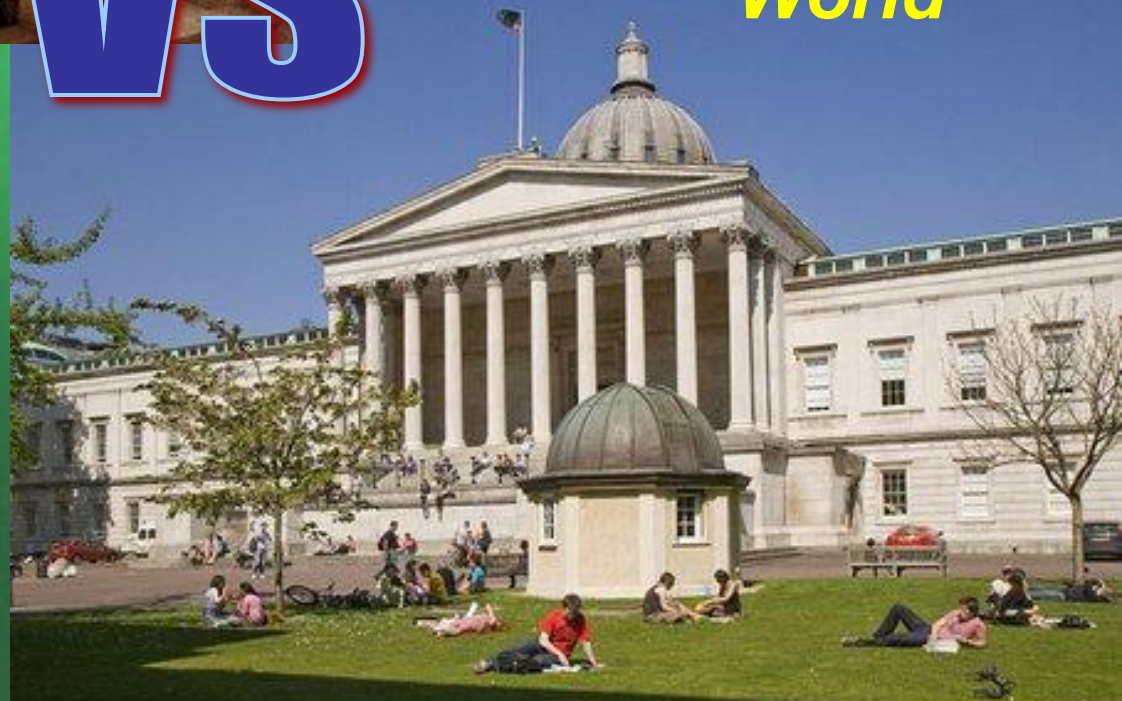

*«If you think... that anything  
like a romance is preparing for  
you, reader, you never were  
more mistaken.*

*Do you anticipate sentiment,  
and poetry, and reverie?*

*Do you expect passion, and  
stimulus, and melodrama?*

*Calm your expectations;*

*reduce them to a lowly standard.*

*Something real, solid lies before you;  
something unromantic as Monday morning,  
when all who have work wake with  
the consciousness that they must rise and*

*betake themselves thereto»*

*(S. Bronte. Shirley)*

*Two nations;  
between whom there  
is no intercourse  
and no sympathy;  
who are as ignorant  
of each others  
habits, thoughts,  
and feelings, as  
if they were dwellers  
in different zones,  
or inhabitants  
of different planets”  
(B. Disraeli. Sybil)*

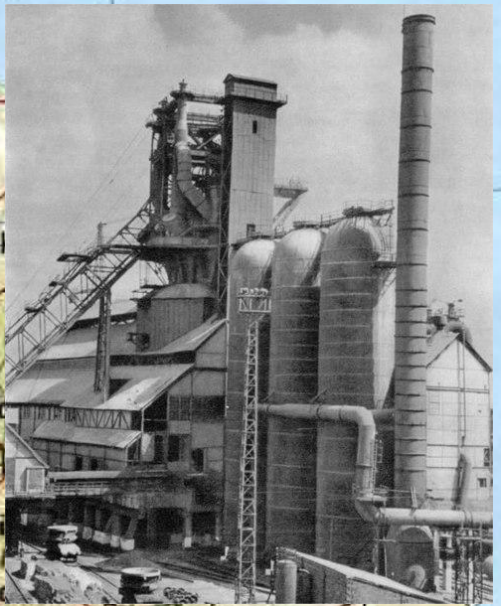
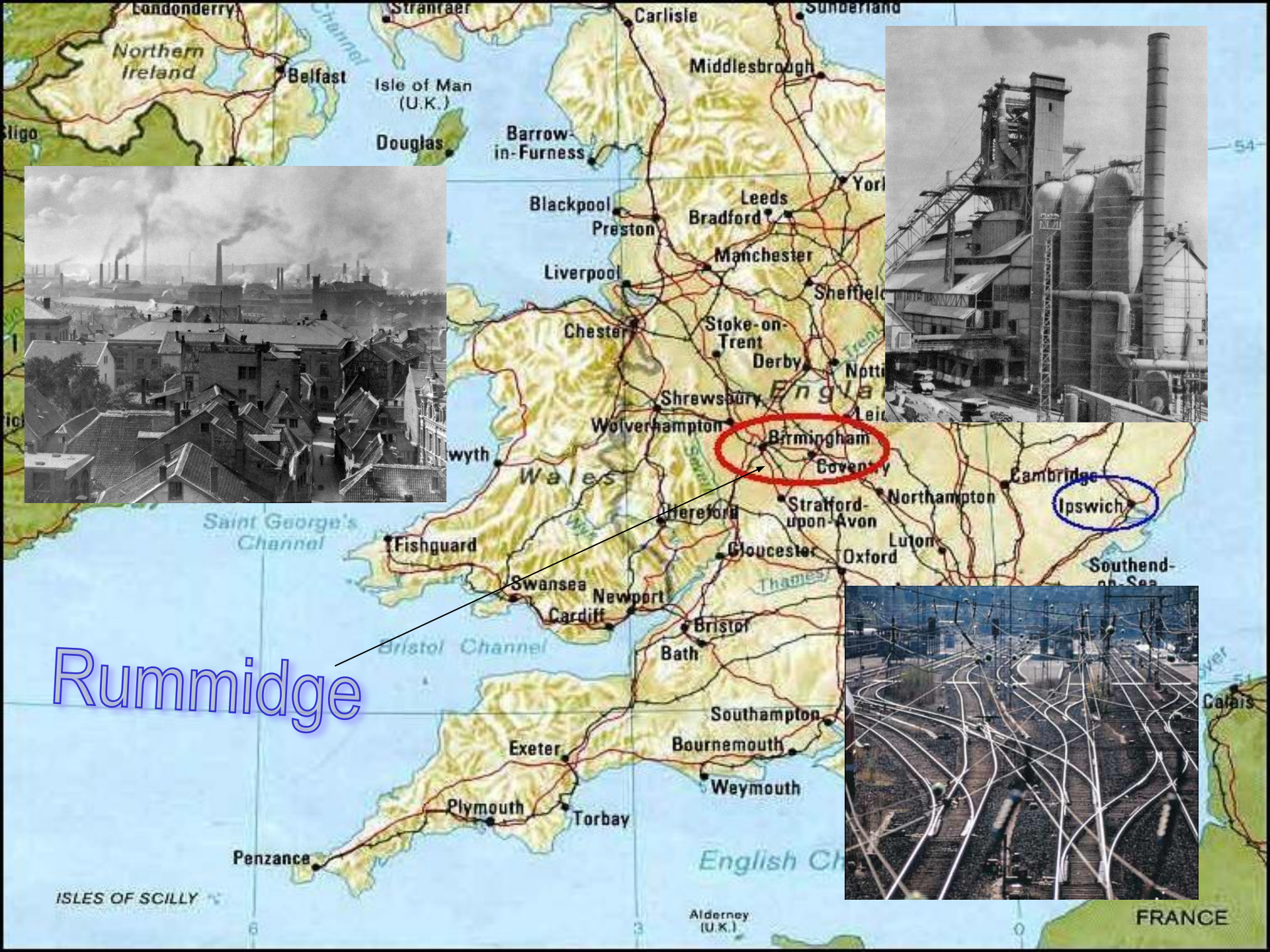

Rumridge

England

Wales

Southend-on-Sea

Calais

FRANCE

ISLES OF SCILLY

Alderney (U.K.)

English Channel

Northern Ireland

Belfast

Isle of Man (U.K.)

Douglas

Barrow-in-Furness

Blackpool

Preston

Liverpool

Chester

Wolverhampton

Birmingham

Coventry

Shrewsbury

Stoke-on-Trent

Derby

Nott

Leic

Bradford

Manchester

Sheffield

Middlesbrough

Carlisle

Sunderland

Londonderry

Sligo

ic

54

6

3

0

K  
O  
B

**Vic**

**Industry!  
Progress!**



**ZYBOR**

**University!  
Revolution!**



**V  
S**



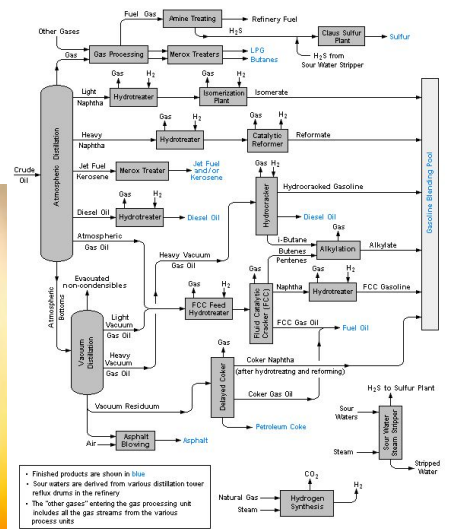

- Finished products are shown in blue
- Sour waters are derived from various distillation tower within drums in the refinery
- The "sour gases" entering the gas processing unit includes all the gas streams from the various process units

# Strikes



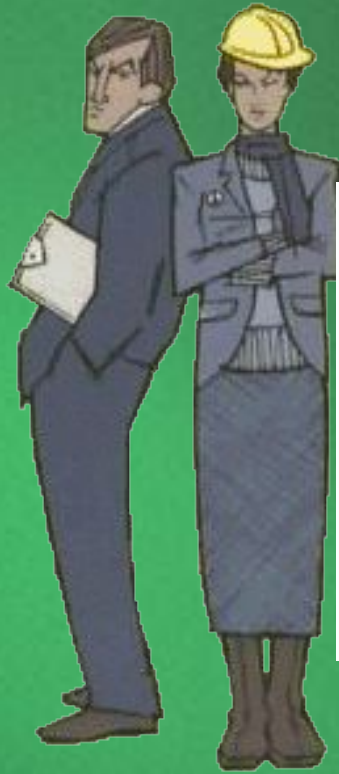





***Thank You!***



*The work was prepared by*

***201 em:***

***Victoria Maslova***

***Darya Kholodova***

***Diana Gazieva***

***Eugenia Pomogaeva***