

How should someone take a phone and a cup, to use this movement of hand for renovation of continuous health

Theory first. In air, as is well known, there is 16% of Oxygen. And when you consume it with air, Oxygen makes Air-Balloon of You.



Combustion of a match



You also know that Combustion Process cannot be possible without Oxygen and that Combustion is Heat release...

It means that where there is Oxygen there combustion is occurring and where the Combustion is occurring there Heat is released .

Fact.



**Pay attention on organization of Man's Body – extended upwards
Chest.**

**HOWEVER ALL MEN
(WHO IS NORM)
ALLWAYS BREATH WITH BELLY.**



WHAT FOR?

As if They keep SOMETHING precious in CHEST.

What is the Treasure that is kept in Man's Body?

Sensephysiology Science asserts: The Treasure is Heat! – as a result of Combustion after Air Oxygen Actions.

It means the longer Man's lungs will keep oxygen inside after inhale the longer and more active will be Oxidation Process - i.e. Combustion – and the more Heat will be released...

AND THIS HEAT WILL RISE UP MAN HIGHER!

As Personal Air-Balloon (here structure of Man's Chest) takes off to the Sky only when it is filled with Heat and when Heat is cherished like the apple of one's eye within it...

That is exactly what Creator of Man's Body wanted to achieve.

Pay Attention to the fact that in average most Men are higher than Women.

WHAT FOR?

Now it is also evident for you.

**Woman's Body Structure is heavier in bottom part,
And Woman breathes (who is in Norm) Not with Belly, as Man does, but only with
Breast. WHAT FOR?**

**Here it is evident for quicker removing of Oxygen from Lungs, not allowing it to finish
Oxidation and then less Heat will be released.**

**Woman's Body Designed by Creator (and
everything is tight-knit) in such a manner that
her Body would not be able to fly up into air to
join «Air-balloon» from Lungs in order to keep
it near the Planet's surface
«Here and Now».**

What for?

**Answer is very simple! Breathing actively with
Breast and as the result cooling inner volume
of Lungs, it will be easier for woman to land
on Planet's Surface in order to sit herself down
to still small Baby ...**

**Creator PROHIBITED WOMAN to breath
with Belly, also in order not to disturb Calm
Development of New Life by muscles
movement during Breathing.**



**NAMELY DUE TO BREAST BREATHING A WOMAN CAN SIT HERSELF DOWN
TO THE LEVEL OF HER BABY ALLOWING HIM TO SEE HAPPY EYES OF HIS
MOTHER!**



**A. PLASTOV
SPRING**

Let's review the theory: Men are projected by Creator in different manner than Women – keeping Oxygen in Lungs, Man can easily fly up above the Planet's Surface, even higher and higher, and due to this he WILL SEE QUICKER : a Danger, and Livelihood, and even Perspective for Family...

For example: New cave or Modern Invention.

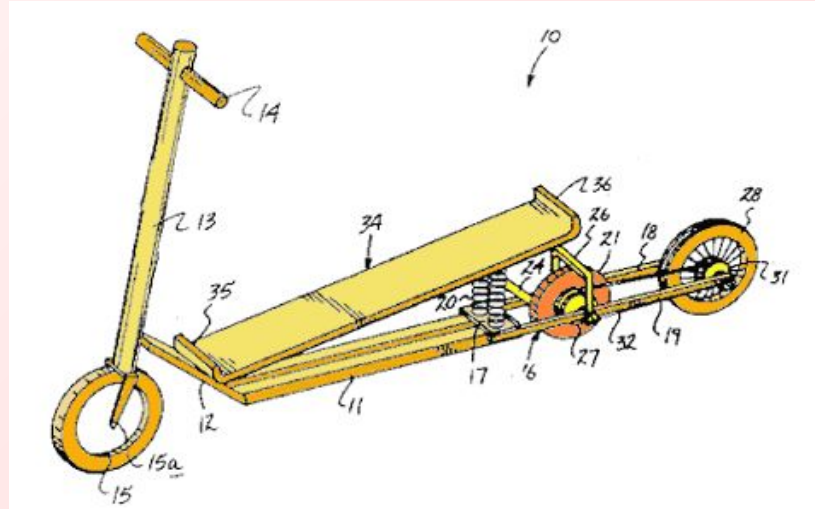

**Thus, having realized the Theory You come to Important conclusion:
As to Creator's conception, MOVIBILITY OF RIBS of Masculine should be minimum,
and the same of Female should be vice verse maximum.
The More Moveable Woman's Ribs are, then more and more Factors of Femininity she
has, and vice verse she loses Femininity,
if her breast is immovable and she breathes with Belly.
Consequently Men when Breathing actively with Chest loose their Masculine Qualities.**

**It will be interesting for you To Know that:
Arches of the Ribs just of Homo Sapiens are**

PARALLEL TO SURFACE OF PLANET IN DIRECTION OF MOVEMENT

**- and Animals have such an arrangement that Ribs and Breastbone, hang down to Ground,
i.e. in direction of Gravitation Forces**

Such an Arrangement of Ribs System just

**«forces» Organism to «correct» Ribs every time - i.e. lift and lift Breastbone upwards, as it
time after time «attempts», as you will note, fall towards the Ground, drawn by Gravitation
Forces...**

Now You and Me know the Reason of Organism Ageing?!

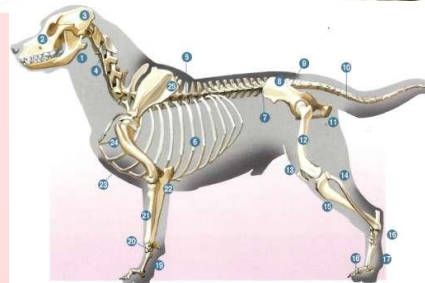
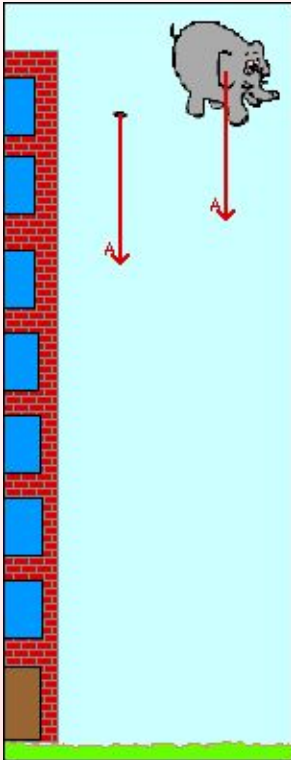

Another one Important piece of Information – for You to Learn the Technology of Continuous Health Renovation when using Phone and Cup.

For sure you know about Implement of Water-diviner! – Water-diviner holds Fork with two branches at an angle and walks up and down with this implement and suddenly point to the place where there is Water. At this place people dig Well.

Pay attention (in the picture) that Ribs System of Homo Sapiens with its arrangement and direction of Breastbone is exactly the same System as Water-diviner’s Fork with Two Branches in.

In other words it is Physiological technology of Water Search.

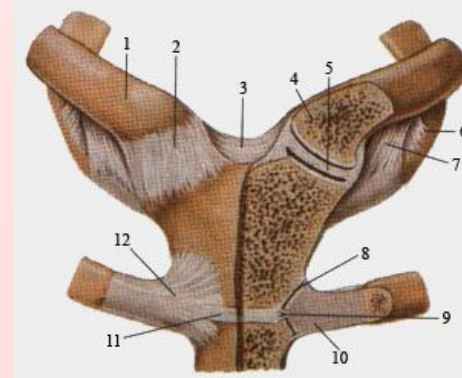

**Water-diviner’s “Fork” in Human Organism
(upper Sternocostal Joints)**

**Sensephysiology Science proves that Human's Ribs System in conjunction with Breastbone is the Implement of Homo Sapiens to Search Information, dissolved in Air Humidity (as in Water). For example, Man is going somewhere then Monades of Air Humidity with Information dissolved in them transmit is «Morse Code» to Bone Lamella of Breastbone «about rightness of chosen way» ...
In other words Inform «Does he follow right direction?».**

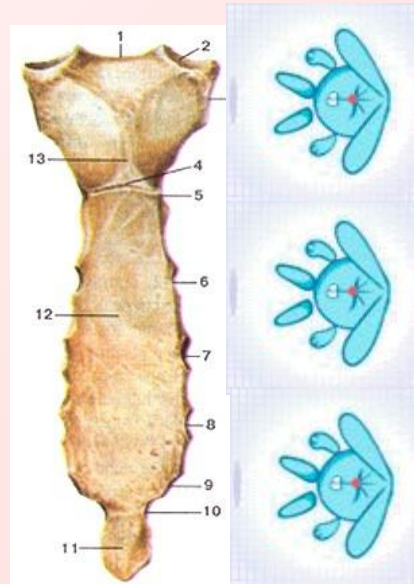

Or let's consider next example – when Human is speaking to Human then the Information in Monades of Water is also «transmitted», but this time in Words. But here Acceleration of Flow of Monades filled with Information occurs as Sound Vibration additionally «pushes» them...

Thus, Breastbone «reads off» the Information from Air Humidity Monades (Molecules of Water) then transmits it to Ribs and Ribs in their turn «reading off» Information from Breastbone transmit it as Vibration to the joints near Backbone, and in this way initiate the activity of Nerve Ganglion of Spinal Cord. And then DIRECTS BODY towards Informational Signal

Coming from Your Goal – i.e. «to the Water».

You may ask me what's that got to do with Telephone and Cup of Coffee when speaking about Renovation of Continuous Health?



It is a Telephone and a Cup that can be used by Homo sensus for Renovation of Lungs' Health Condition.

It means with this Movement of Hand to set Ribs System and Breastbone to Motion and just by this to change corresponding Normalization Processes of Oxidation Processes and Gas exchange which occur in Lungs.



And even to cure Lungs!
When their Health of Particular Person is
deteriorated by some Factor.
And it is very important! As Human starts his life
in our world with the moment of Lungs Opening
(from the First breathing-in) and leaves this world
with Lungs Closing (Last breathing out).

Thus, Movement of Arm with Telephone and Cup is Outstanding Instrument not only to
continue Life in Condition of Continuous Health
(due to Normal Performance of Lungs as Beginning of Life on the Planet),
but also as will be explained further for Renovation of Femininity and Masculinity, by
means of appropriate normalization of Hormonal Systems...
namely by special Skill of using Telephone and Cup!



I repeat the Important thing – for Renovation of Continuous Men's Health, they need to maintain status quo of Lungs filled with Oxygen. Therefore, if You are Man, take a Telephone to make a call or when somebody phoned you, and bring receiver to Ear, SETTING ELBOW AS MUSH AS POSSIBLE ASIDE FROM BODY (this Movement You know from cinema as «hussar's toast»).



With this Movement You not only «mechanically» extend the Chest Volume Capacity – but You also Rise Ribs to the Level parallel to the Planet's Surface and by doing so You direct Breastbone towards «Information Collection».

That is what needed to be achieved to increase Masculinity and other Fundamentals of Ideally Healthy Man's Organism. In the same manner you should act with cup of coffee.

Attention! When performing «Telephone» Technology for Renovation of Lungs' Function and Yourself as Man and all Your «Men's» Functions...

When performing this Act of Self-renovation there is another one significant moment. When You using Telephone EXACTLY IN THIS MANNER (in hussar's manner)

make Movement of Arm and then at the other end of Telephone Connection that Person, who is communicating with you, considers You as self-confident Person and Person confident in his Capabilities «in Men's Entourage».

And Responds correspondingly.

You and Your Voice during phone conversation is in fact Vibration which having passed together with Vibration of Telephone Signal through Noosphere of Planet will vibrate namely like Yourself as Real Man in Subconscious of Your Conversation Partner.



**By the way, during analysis with the help of slow motion pictures Attention was paid to instinctive rise of Ribs and Breastbone of Men when meeting Woman...
Now owing to Sensephysiology Science and principle of Dowsing of Water
You know what for – for «Information Collection».**

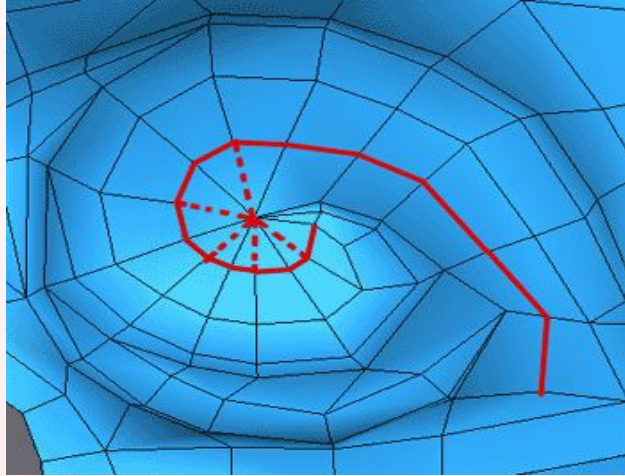

**This is the scheme of Human Ribs System
Ergonomics**



**And this is its analogue - which You
know as Hieroglyph from Naska Desert**

**Here the are no differences in the Processes– as it evident!
WHAT FOR?!**

Woman in order to Renovate Function of Lungs

(i.e. for Renovation of Life Period by Human)

Brings Telephone to Ear SENDING ELBOW TO CENTER OF THE BODY.

As you understand, by doing this she concentrates weight on the Tip of Elbow and her Arm, in order to use its weight to Help Ribs to sink down and to push residual Air and Heat from from Lungs as much as possible... That creates conditions for «Air-balloon sinking down» - it means to provide opportunity for knee bending.



This movement of Elbow recovers other Programs of Ideal Healthy Women's Organism (including Femininity!)

By the way, our researches proved the Fact, that this Movement of Woman's Arm is also... Instinctive! – when she uses Cup and Telephone in the Presence of Man. And if she is «hormonally» Healthy just the fact of this movement can identify who phoned her – Man or Woman.

**Now You are Cognizing Sensephysiology Science as Basic Philosophy and
Practice of Physiological Culture!**

That is why next time take Telephone (Cup) with Opposite Hand!

**Remember that *Homo sapiens* will be *Homo valetudinis* and therefore *sapiens*
during the time**

**while he Continuously Reestablishes in Himself the Balance of Mobile Verticality
- as Balance between Left-Right, Up-Down, Front-Rare and so on.**



But when using Cup as the Technology of Continuous Health Renovation there is a small difference. This difference is in the Technology of Fingers Movement for Man and for Woman. Though this Factor of Difference exists when using Telephone, it is not it to be Determinant.

Pay attention to the fact that Woman when she has Normative Performance of Hormonal System and her Woman's Nature without any doubt is in Health Condition and when she is Filled with Femininity and Radiates Femininity - she takes Cup approaching it with wrist and holding it with Palm as if Petting Child's head!



**Vice Verse, Man, who has good Normative Indicators and Indicators of Hormonal Health,
Takes Cup as if «grasping» it with Fingers, and even inserts Forefinger into handle of the cup, or take hold of it on the edge, when handle is small
(see. Law of Correspondence).**

**It is important to Realize here and TO FEEL YOURSELF that taking Cup either in «women's manner» or in «men's manner» You automatically do Yourself corresponding Movement of Elbow or to the Center of the Body
(women's Program Movement)
or «in hussar's manner»
(Men's Program Movement).**

This Sensephysiological Fact proves that Creator's Conception is being realized by means of Program of Ideal Organism Structure.

**Here it will be useful for Men to get one more piece of Information from me : the more you feel (even do it intentionally) touching tightly Cup's Edge with tip of Thumb as Correspondence of Head and Beginning of Vibration Meridian of Lungs (see. schemes)
and it will put itself on the place for sure –
The higher You will have the Indicators of Internal Force.**

And, Pay Attention that Woman taking Cup «in women’s manner» sets отставляет Little finger aside... But Men’s Little finger is vice verse it pushes with its Tip against the Point of Palm known in Chinese Medicine as «Small Storage Container», (this storage container in Human’s body is Gallbladder in which bile is stored).

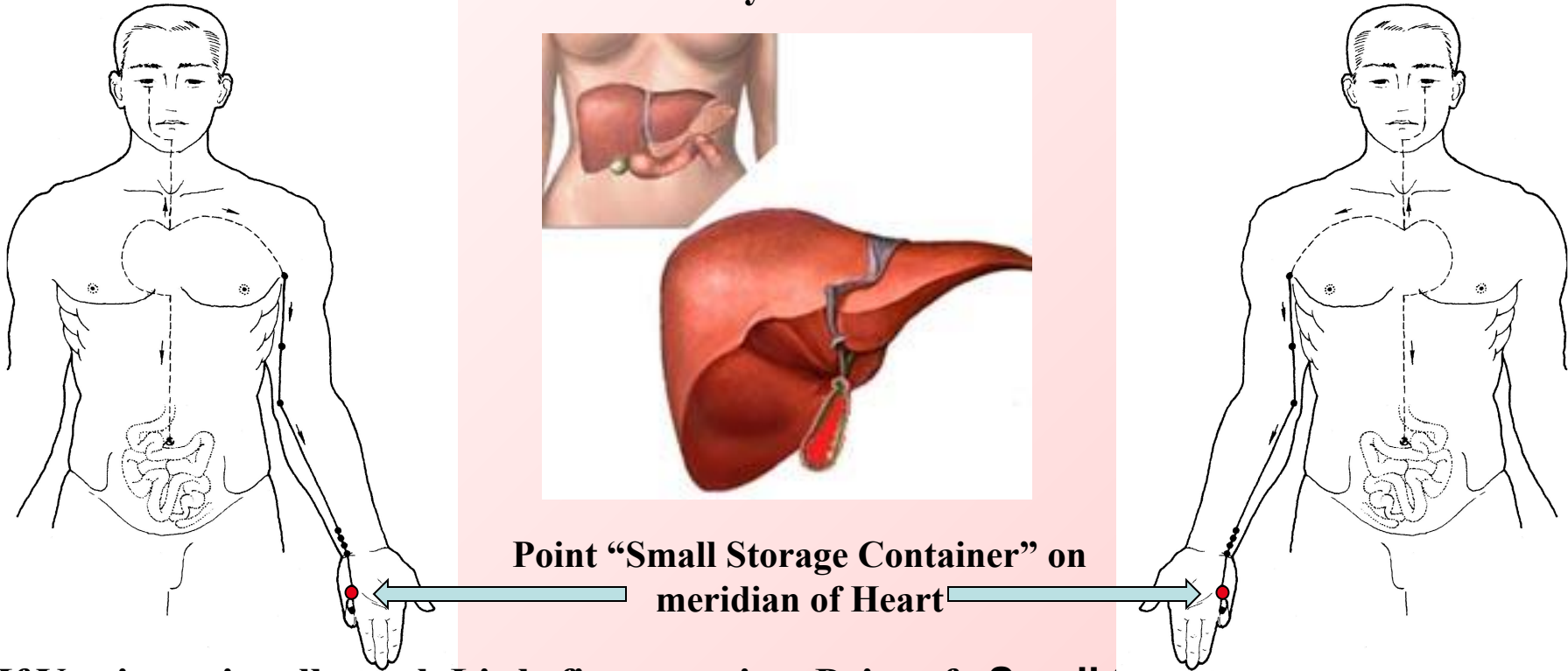

If You intentionally push Little finger against Point of «Small Storage Container», then You will not be able to perform «Drinking in women’s manner»!

Women have everything quite the reverse –

If Woman sets Tip of Little finger aside when using Cup for Femininity Renovation she also will be not able to drink “in men’s manner”!!!

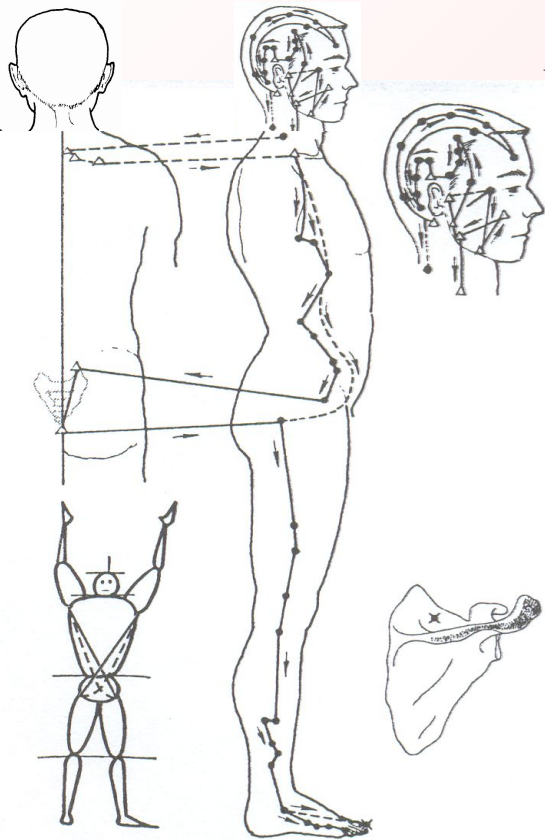

Energetic Meridian of Gallbladder

It is exactly the Gallbladder according to ancient medicine that due to its Energetic and Function provides Strength, Activity and Health to Human's Muscles that is why Men's Gallbladder according to Medical Statistics almost never suffers from disease
RATIO OF DESEASES INCIDENTS AMONG MEN AND WOMEN IS -1/100!

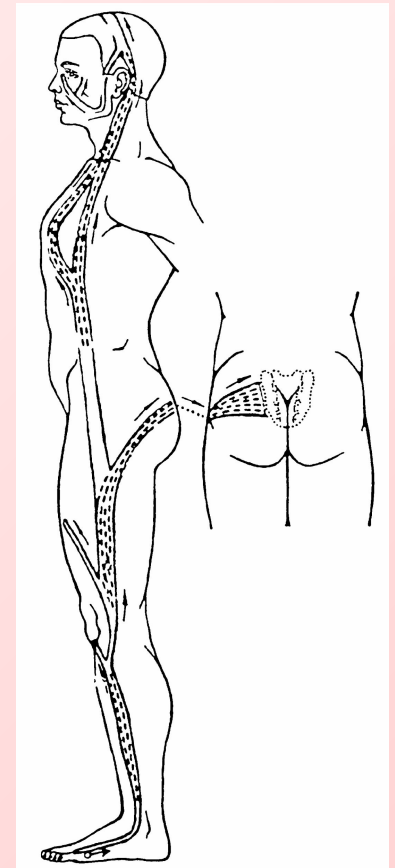

Vibration Meridian of Gallbladder

By the way – Information for Women – WHEN You stop touching «Small storage container» WITH Little finger and set it aside then Your Gallbladder stops disturbing You.

If You being a Man take Cup with Thumb, Middle finger and Forefinger, and the rest Fingers will be Knuckled – then Effect of Renovation will be insuperable! As by pressing with Thumb You «train» all Intercostal Muscles (due to action of Vibration Meridian of Lungs see the scheme).

And by pressing with Forefinger – You Train Strength and Function of Rotator Cuff and Arms, with Middle finger you Train Legs. (all this happens due to Action of Law of Correspondence)

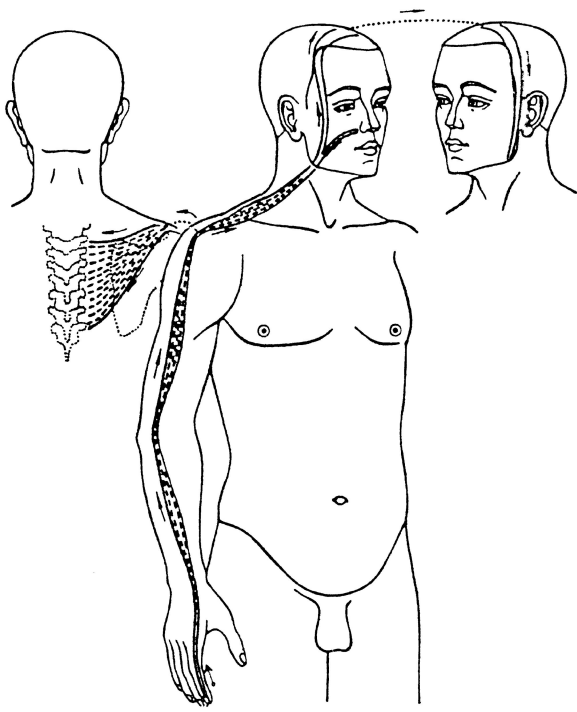

Vibration Meridian of Large Intestine

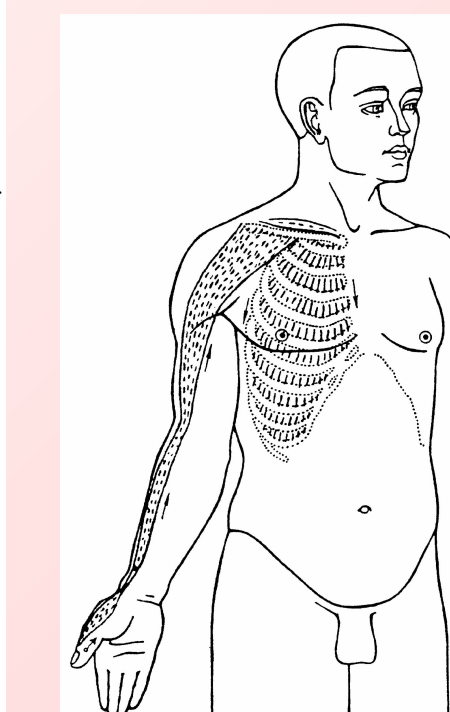

Vibration Meridian of Lungs

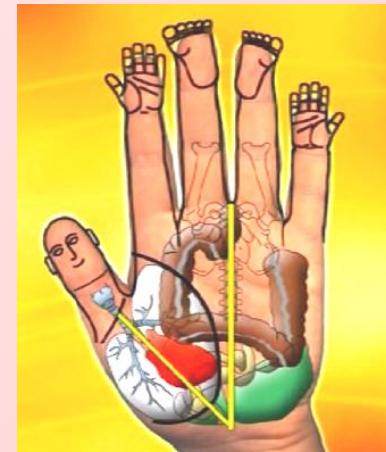

**Law of Correspondence is in Action!
Forefinger is Vibration Meridian of Large Intestine,
and with Its Actions it is Your Mini Hand**

Another one important supplement to the information mentioned above.

Pay Attention that handle of Cup when using «men's» Technology AUTOMATICALLY SUPPORTED BY Middle finger against Corresponding Point from Chinese Medicine DZU

SAN LI - «Great Healer» (exactly!) and even «Immortality Point»

(this Point is located on Leg under Knee...)

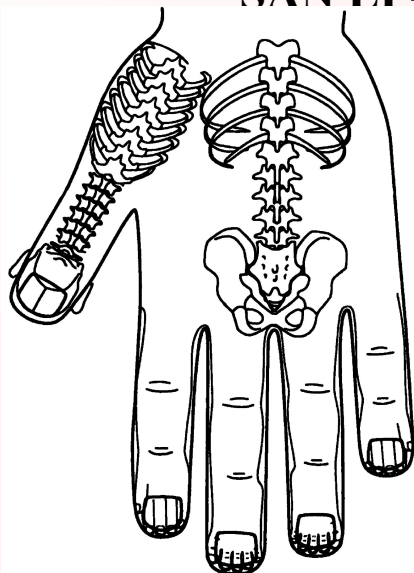

Law of Correspondence is in Action!

Middle finger of hand is Your Leg.

Middle Joint of Middle finger is Your Knee, and where Handle of Cup rests on Middle finger then

“Great Healer of Legs” Point!

When you finished Drinking Tea or Coffee as *Ho sensus* it means you have provided Strength and

Restored Health of Legs!

(“to chase mammoth”)

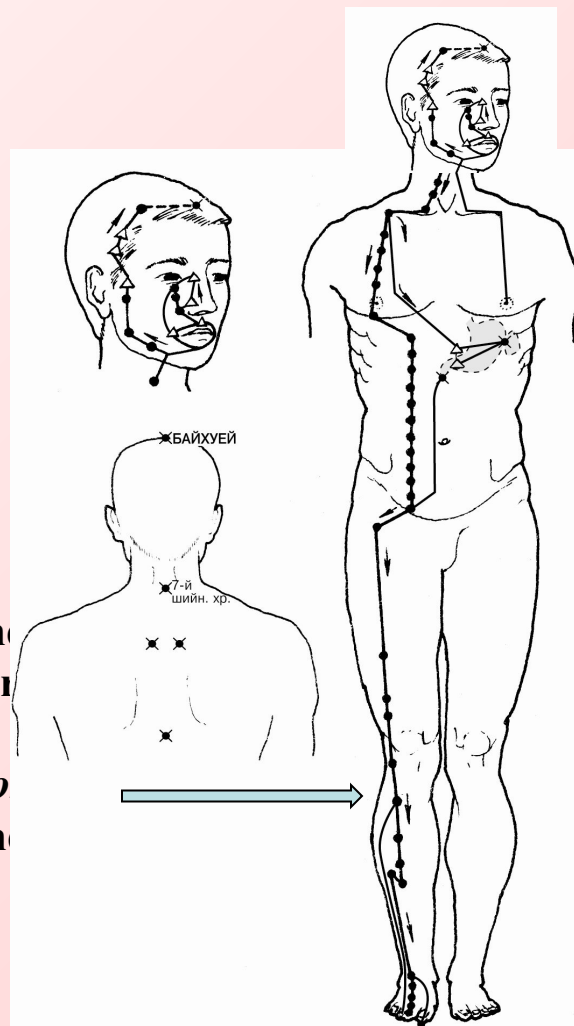

“Great Healer” Point
Religions of
other-father suggest to
Knee
***Ho sensus* now knows**
WHAT FOR!

To Knee means to Free Fingers and provide Strength to Arms.



Pay Attention

how Light the Jug looks like

каквим светлимим болитидит кувшини

**Another one additional Technology of Masculinity and Femininity Renovation is
Technology of Continuous Health Renovation of Hormonal System using
MOTIVATION OF THE OPPOSITE HAND.**

**What does it mean? You hold Telephone or Cup according to Your gender.
But at the same time Men direct Nail of Thumb of OPPOSITE HAND towards the
ground and twist it.**

**Effect of Masculinity Appropriation is unusual expanding of Thumb and entire Hand
towards Center of Planet,**

**Women hold Palm of OPPOSITE HAND with extended Fingers parallel to ground and
twist Tip of Little finger set aside.**

**Effect of Femininity Appropriation is when Woman's Palm in Wrist rises itself
upwards and Fingers in uncommon manner will extend exactly to the Level of Planet's
Surface – even Feeling of Palm Surface «Sticking» to the Planet's Surface appears.
Next time apply the same Technology of Hormonal System Renovation as Motivation of
the Opposite Hand to the other hand.**

It is Necessary for Renovation of Sense of Gravitational and Anti-gravitational Upright.

And now «Joke»of Sensephysiology Science:

Don't you mind to «stir» Your Hormones and «stir» Oxygen!?

For this purpose Man should hold Cup directing Wrist to it and «embracing» it with Palm «in women's manner» and then set Tip of Little finger aside, and drink from it directing Elbow towards Center of the Body.

And for women «joke with Hormones and Oxygen» is to hold a Cup «in men's manner» - «grasping» by Tips of Fingers, then Thumb presses from above, Forefinger enters the handle – and automatically Middle finger bears weight of Cup ... Little finger pushes against point of «Small Storage Container»... and drink, setting Elbow aside «in hussar's manner».

Or to «joke» even more – to apply Motivation of the Opposite Hand again (it is the most effective «Joke»).

For this purpose Man when drinking holds Elbow in hussar's manner, but holds Palm of the Opposite Hand Parallel to Planet's Surface and twist Tip if Little finger...

But for Upright Renovation be sure to Change Hands.

Using the «Joke» Pay Special Attention that Your Palms and even Hands will be themselves held «in women's manner» - such a Huge Strength and Great Speed of Hormones «rebuilding» !!!

(that is always should be taken into account by *Homo sensus*)

Women «Joke» in opposite manner – they drink from a Cup holding Elbow in Women’s manner (towards the Center of the Body), but simultaneously it is necessary to direct Thumb of the Opposite Hand downwards and twist its Tip towards the Center of the Planet. By doing this – Pay Special Attention how You «will be launched to the Air» (Your Chest turned into Air Balloon).

Such a Huge Strength and Great Speed of Hormones «rebuilding»!!!

Next time “stir Hormones and Oxygen” by other Hand - for Renovation of Law of Axe (Law of Verticality) in Organism) – in other words Sense of your Gravitational and Anti-gravitational Upright.

(here “to Caesar the things that are Caesar`s ” - Men need Renovation of Sense of Anti-gravitation, and Women need Sense of Gravitation!).



**And now Technology of RENOVATION AND BALANCE FIXATION –
Hold Cup with two Hands (according to Your Technology) –
Men hold with Thumbs, Middle fingers and Forefingers,
The rest are knuckled (Little finger on «Small Storage Container»),
And Women - «holding Cup in their hands women’s manner» and setting Tip of Little
finger aside.**

**It is necessary only to control uniformity of pressing each Finger both to a Cup and to
Palm!**



“OPPOSITES GIVE BIRTH TO OPPOSITES”

LAW OF SENSEPHYSIOLOGY SCIENCE

What for do you need such «jokes» and «stir» Hormones and Oxygen?

For the same reason – for Renovation of Continuous Health.

Because You as Homo sensus directing Oxygen in System of Lungs through absolutely different ways

provided Organism with Additional Opportunities to Protect You ...

And specifically here – Opportunity for Your Ribs to move in totally different manner in Sternocostal

and n Costovertebral Joints «involving» the opposite part of the Body.

This followed not only by Flow of Nervous Impulses from Spinal Cord but also Flow of Life Energy and Hormones all over the Organism.

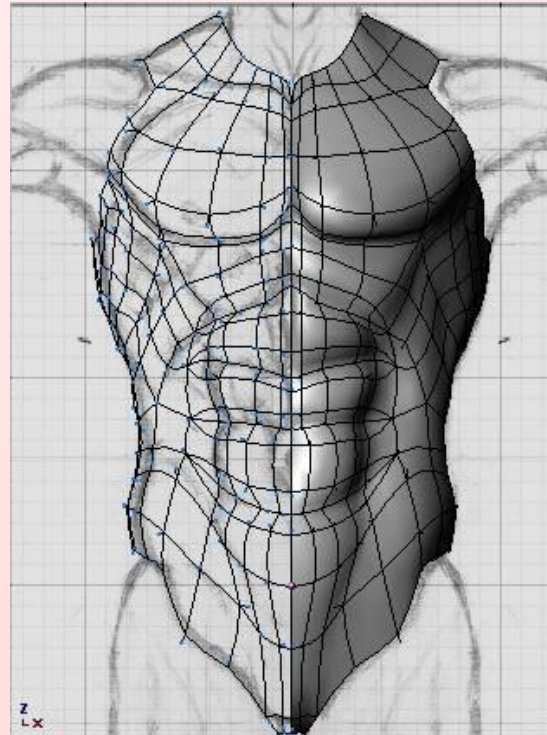

SUCH AN ORIGINAL ACT OF RENOVATION

As Use of Telephone and Cup by Homo sensus

is to start absolutely uncommon Flows of Internal Processes!

**And then New flow of Internal will correct something will expand what has narrowed
and will narrow properly what has expended
GOOD LUCK!**



**Such your Actions (as help from Homo sensus)
sometimes are just necessary**

—

**TO GIVE UP HABITS -
which are the main causes of most of the diseases
that Homo sapiens suffers from!**

**professor Alexander Kharchenko
Lutsk, phone: 80508760217
mail: sensfjzjologika@gmail.com**