

ANTIFOLATI

FOLATES

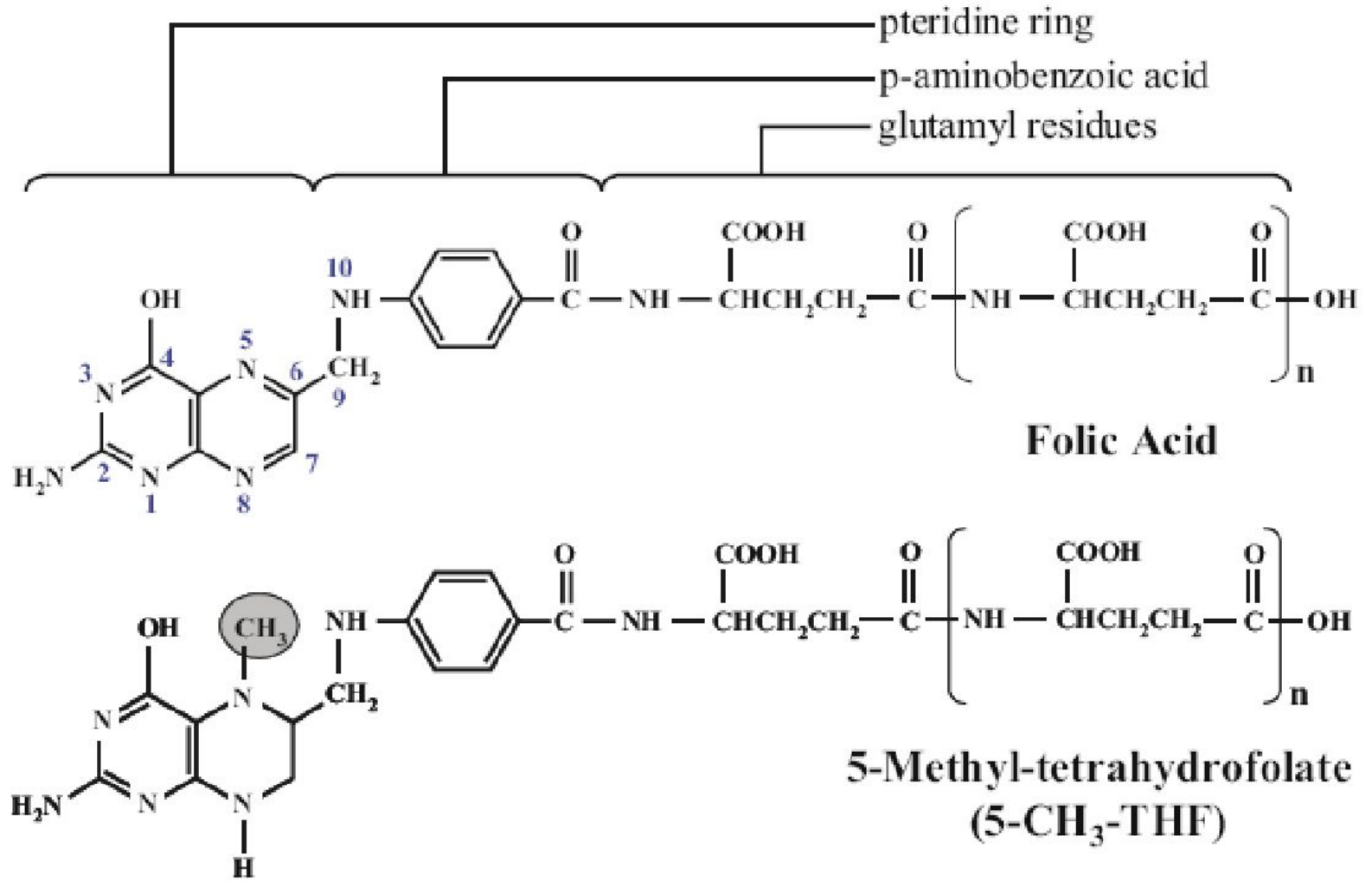

ANTIFOLATI

ANTIFOLATES

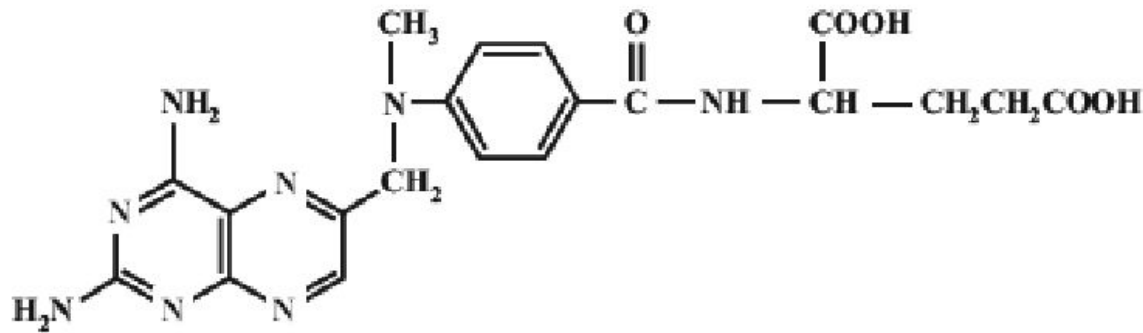

Methotrexate

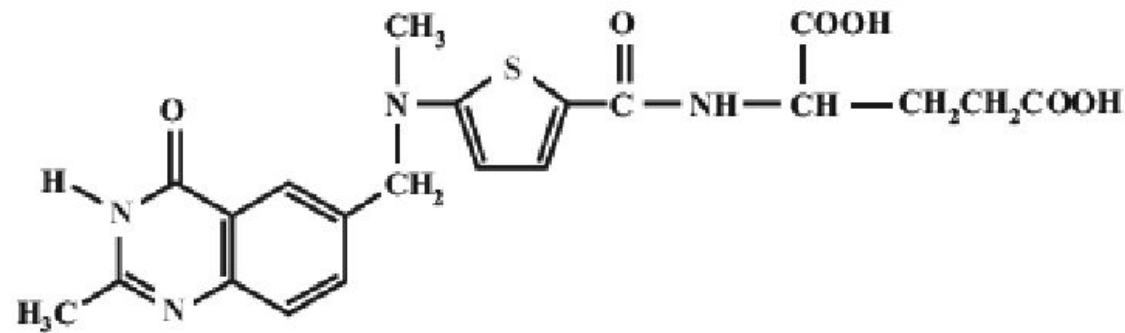

Pemetrexed

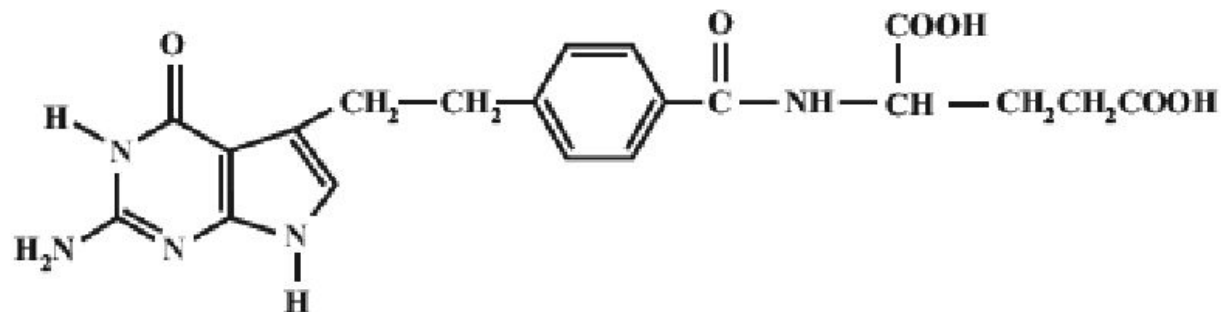

Raltitrexed

MECCANISMI DI TRASPORTO DEI FOLATI

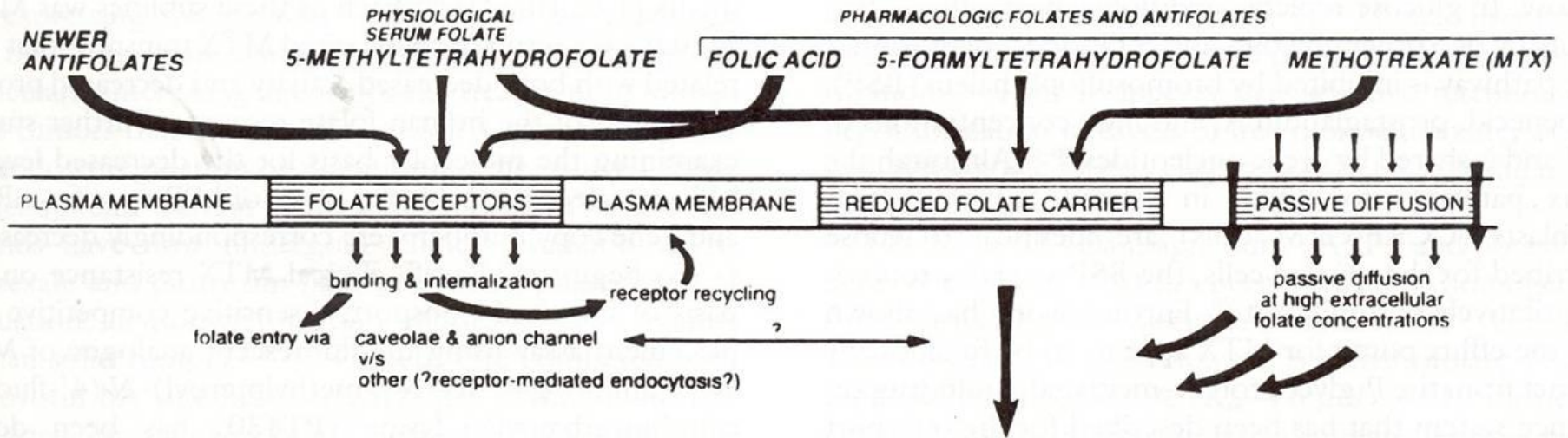

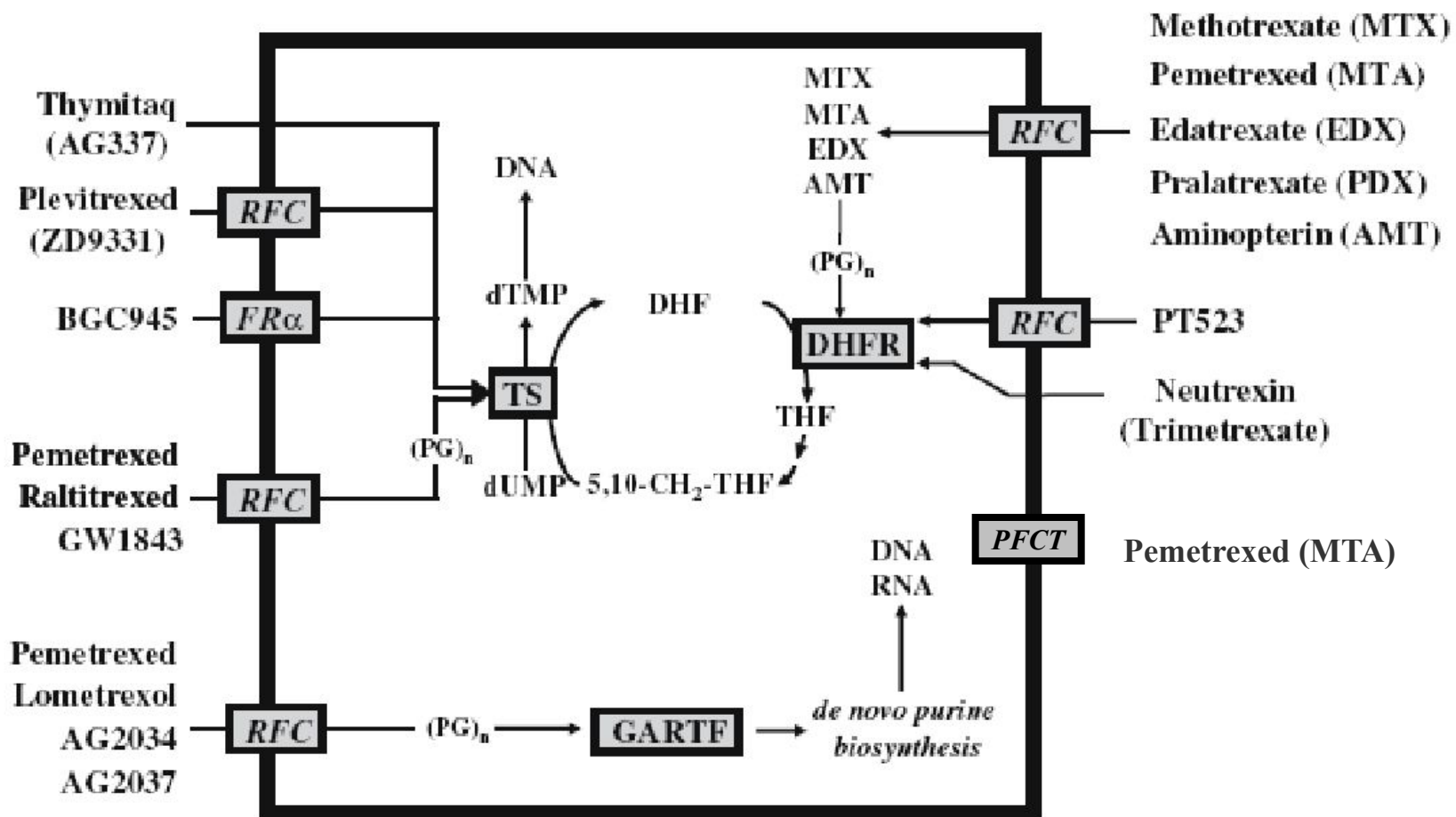

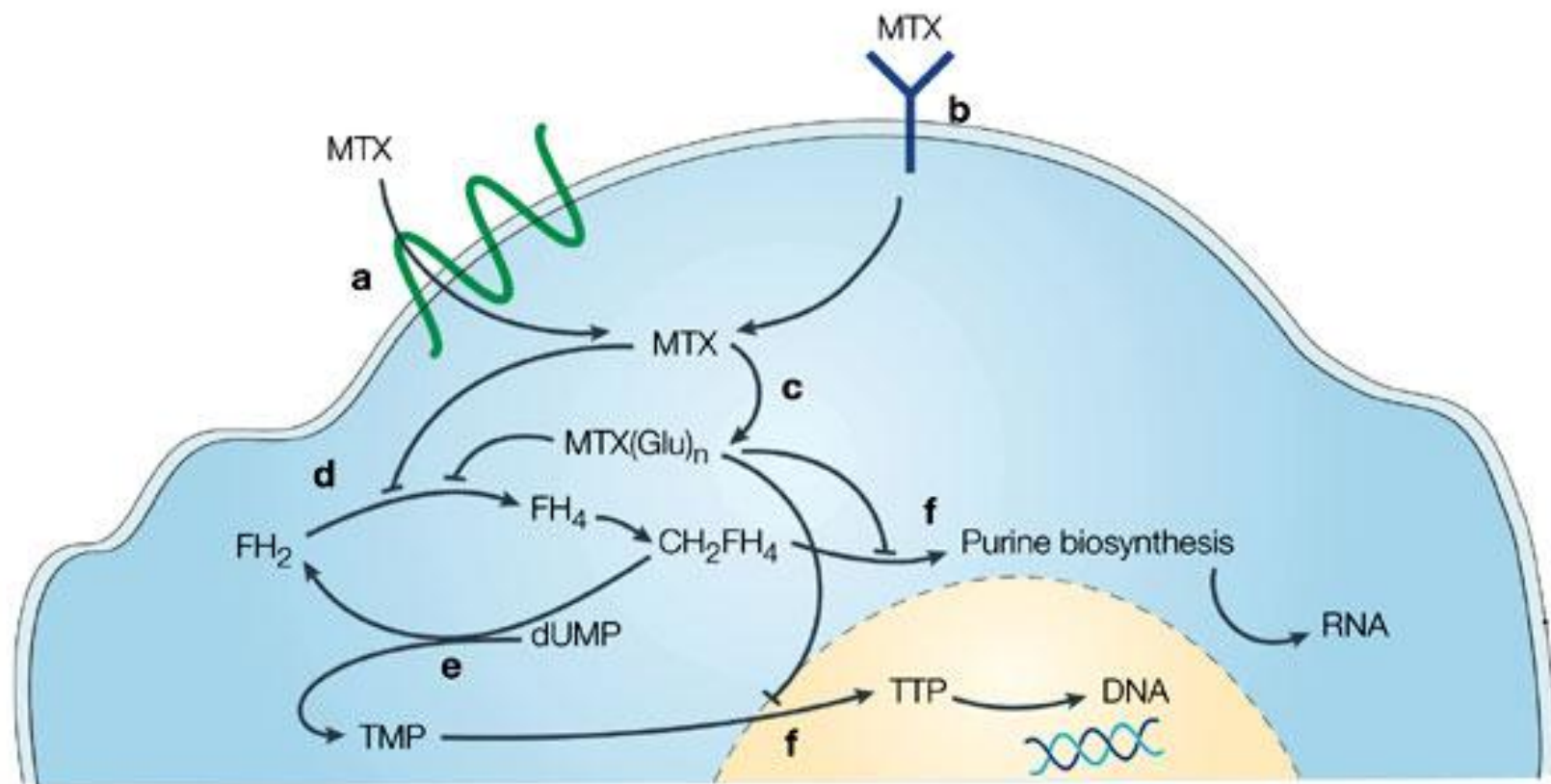

MECCANISMO D'AZIONE DEGLI ANTIFOLATI

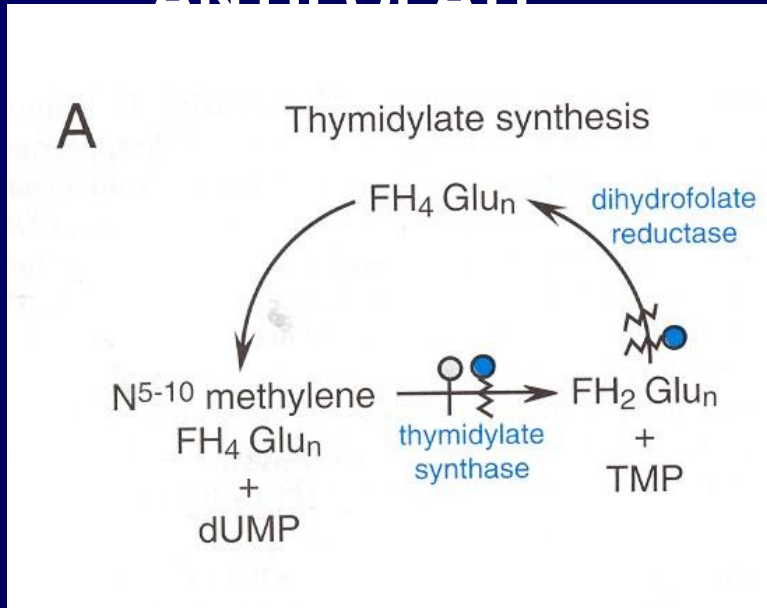

INIBISCE

MTX Diidrofolato reduttasi

Diidrofolato reduttasi

Timidilato sintetasi

MTX(Glu_n) AICAR transformilasi

GAR transformilasi

Timidilato sintetasi

FH₂(Glu_n) AICAR transformilasi

GAR transformilasi

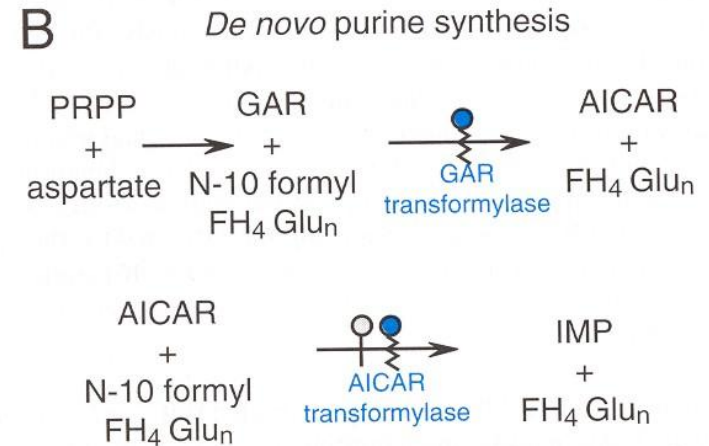

REACTION INHIBITED BY:



Figure 52-5. Sites of action of methotrexate and its polyglutamates.

AICAR, aminoimidazole carboxamide; TMP, thymidine monophosphate; dUMP, deoxyuridine monophosphate; FH₂Glu_n, dihydrofolate polyglutamate; FH₄Glu_n, tetrahydrofolate polyglutamate; GAR, glycinamide ribonucleotide; IMP, inosine monophosphate; PRPP, 5-phosphoribosyl-1-pyrophosphate.

BIOSINTESI DELLE BASI PURINICHE

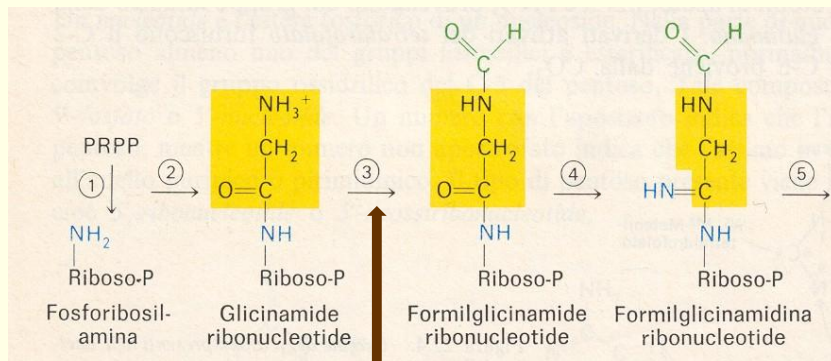
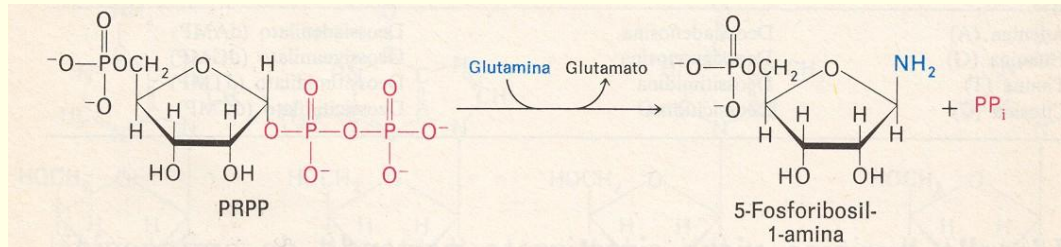

METENILTETRAIDROFOLATO

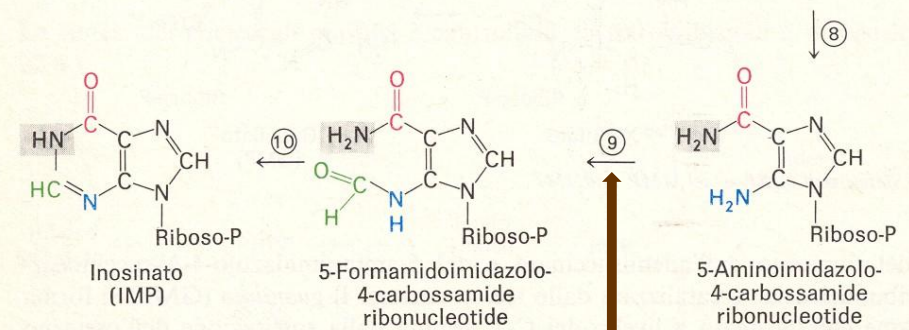
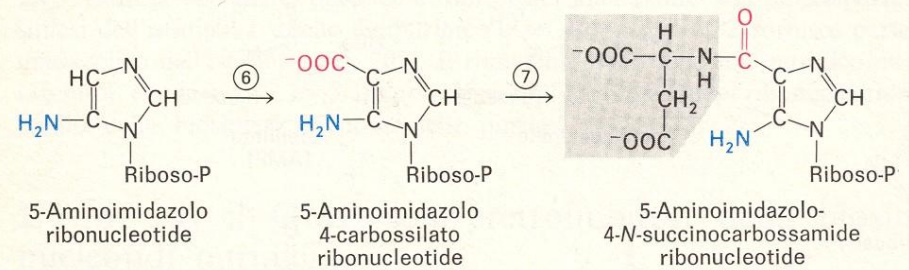

N¹⁰-FORMILTETRAIDROFOLATO

EFFETTI COLLATERALI DEGLI ANTIFOLATI

- mielosoppressione, trombocitopenia
- polmonite
- fibrosi epatica e cirrosi
- embriotossicità

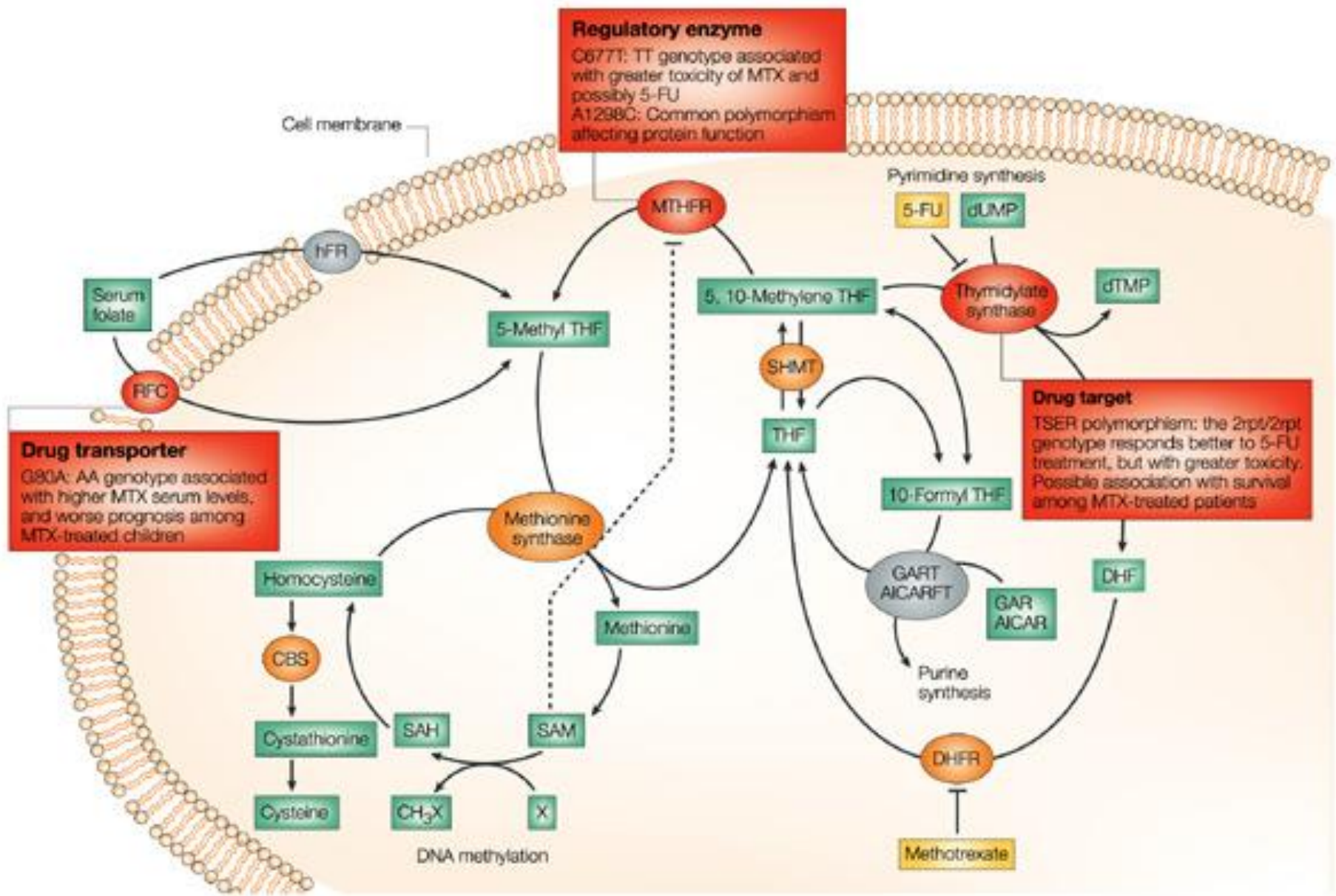

ASPETTI FARMACOGENETICI

SNP a livello del gene che codifica per MTHFR

Diverso numero di sequenze ripetute a livello di
TSER

SNP a livello del gene che codifica per RCF

MECCANISMI DI RESISTENZA AGLI ANTI-FOLATI

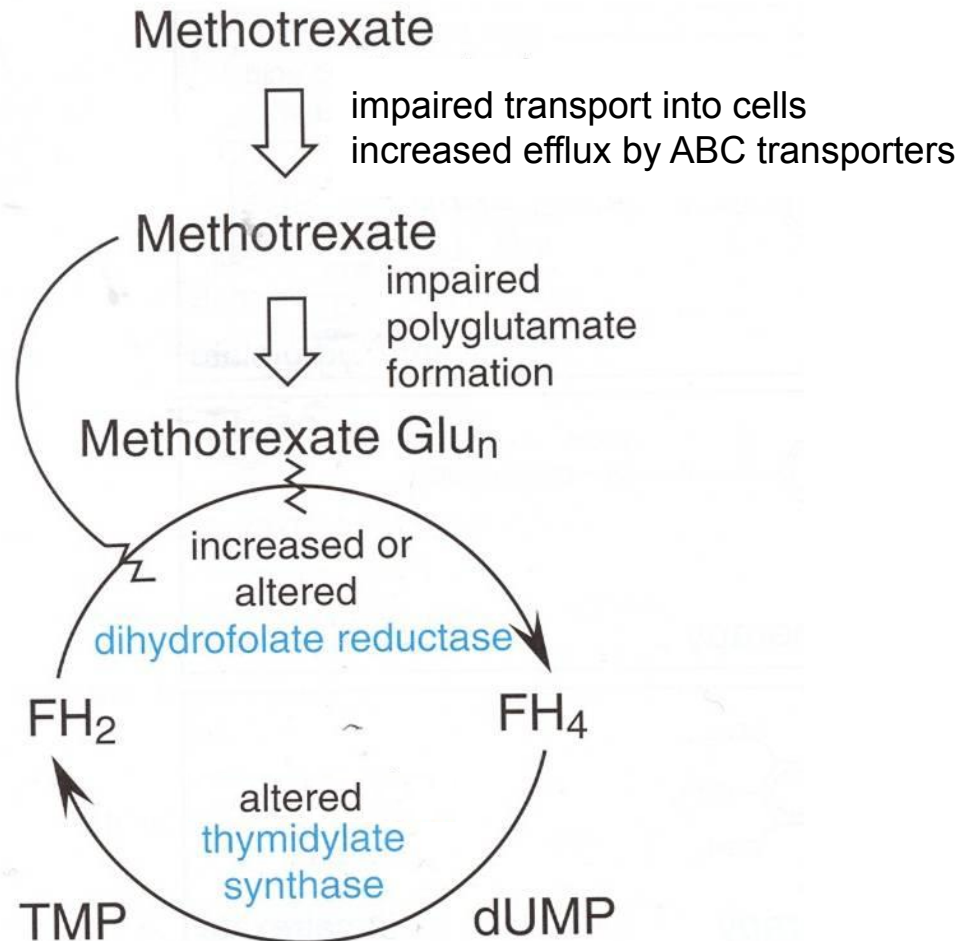
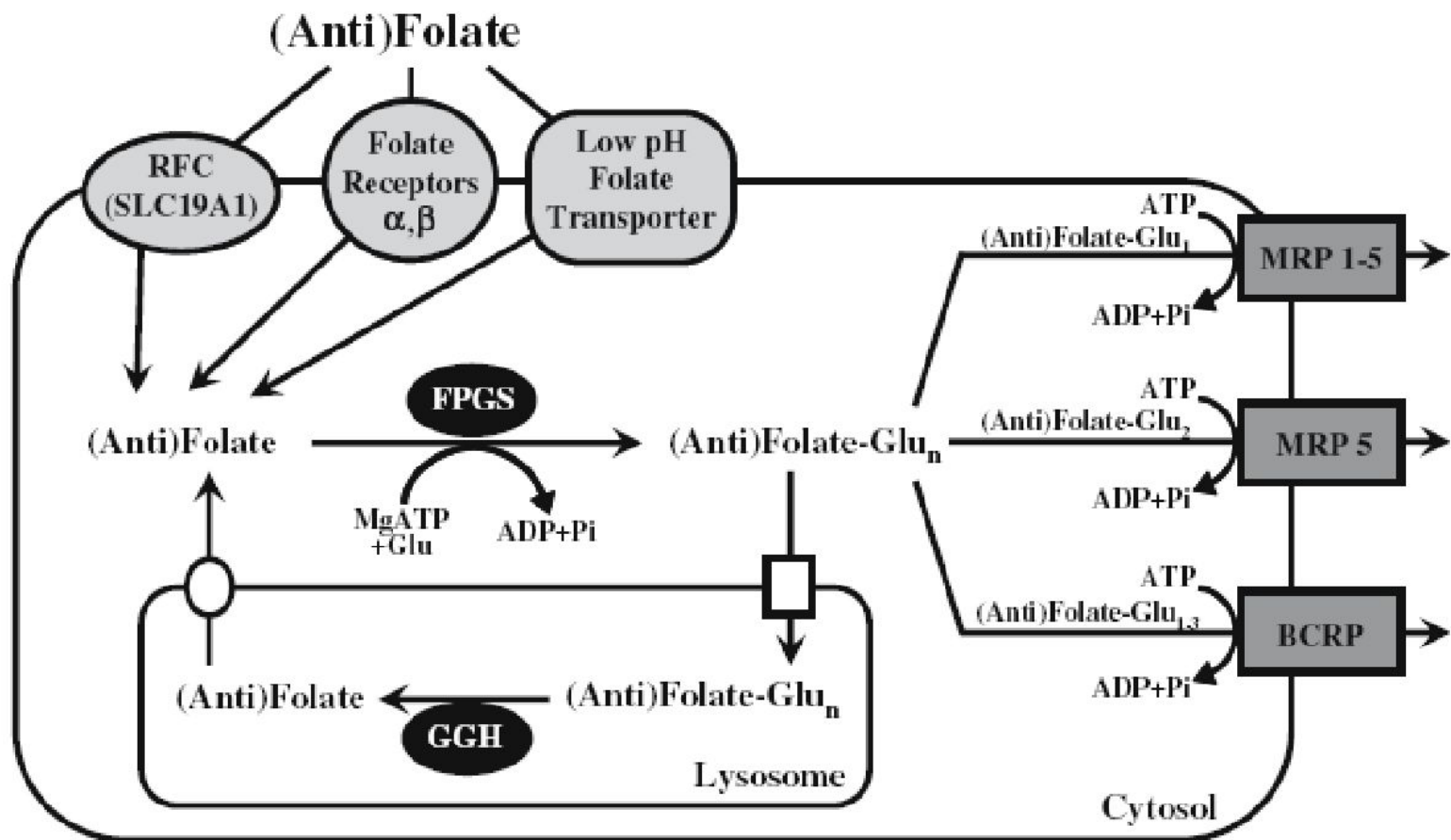

Figure 52-7. Mechanisms of tumor cell resistance to methotrexate.

TMP, thymidine monophosphate; dUMP, deoxyuridine monophosphate; FH₂, dihydrofolate; FH₄, tetrahydrofolate; Glu_n, polyglutamate.



MECCANISMI DI RESISTENZA AGLI ANTI-FOLATI

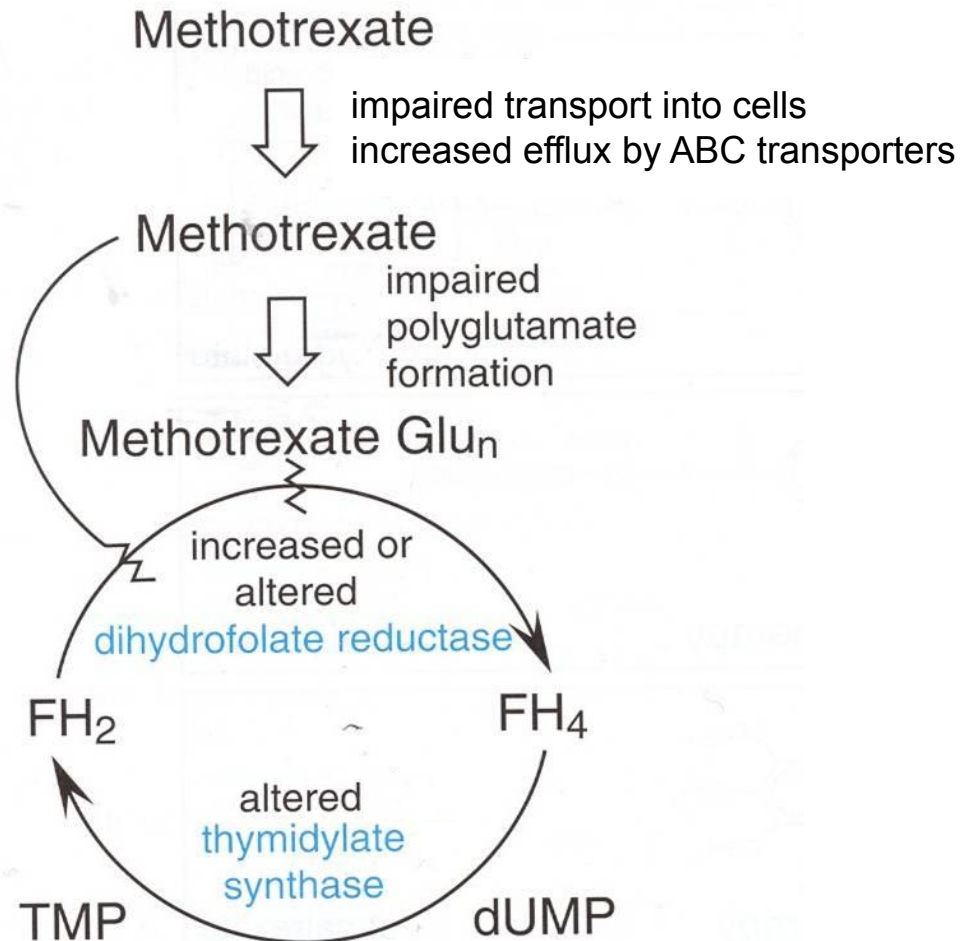
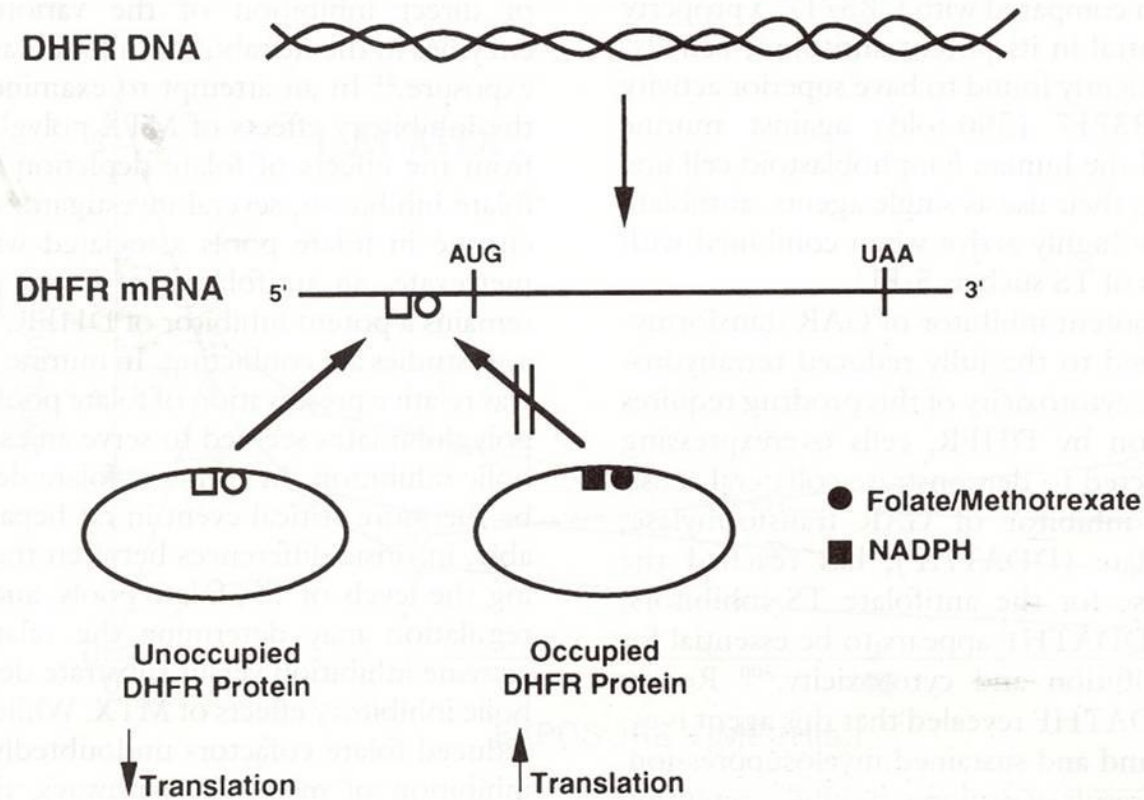

Figure 52-7. Mechanisms of tumor cell resistance to methotrexate.

TMP, thymidine monophosphate; dUMP, deoxyuridine monophosphate; FH₂, dihydrofolate; FH₄, tetrahydrofolate; Glu_n, polyglutamate.

Figure 6-6. Proposed model for autoregulatory control of DHFR mRNA translation by DHFR protein.



MECCANISMI DI RESISTENZA AGLI ANTI-FOLATI

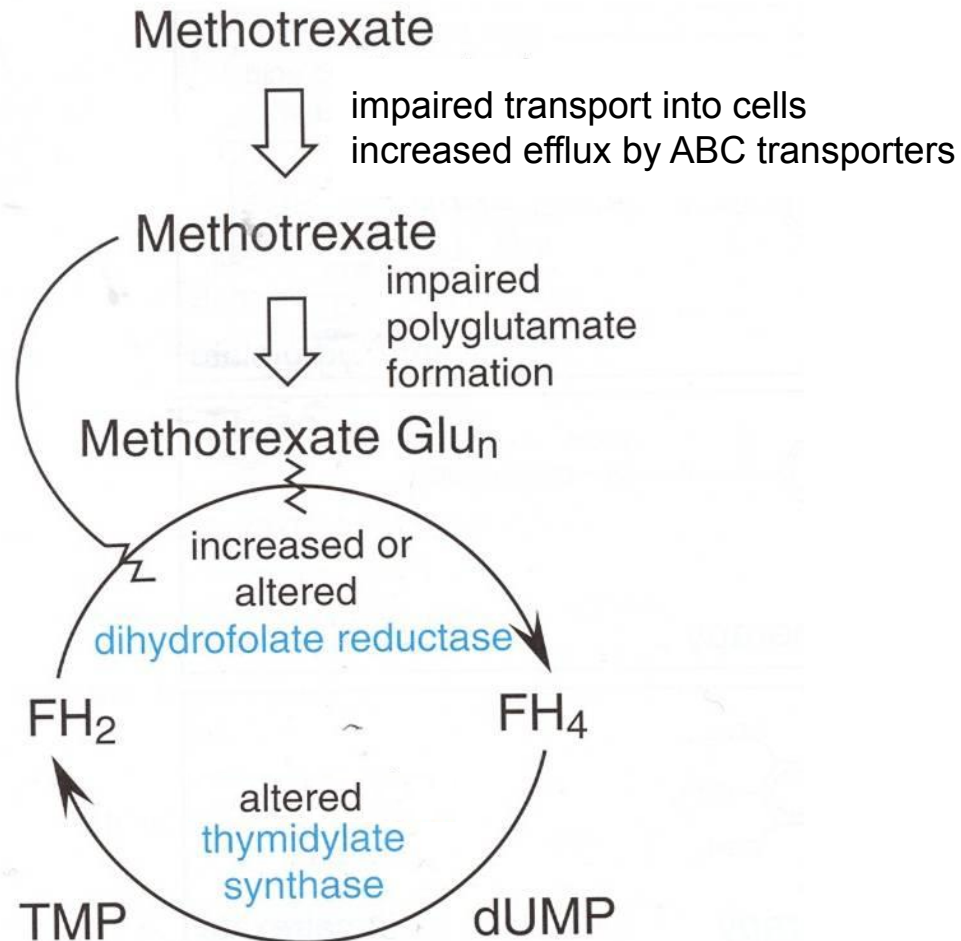
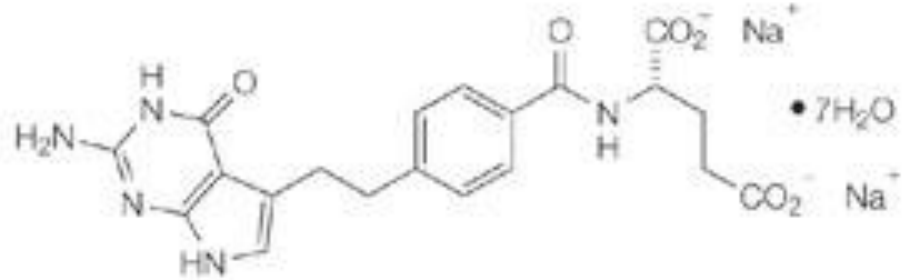
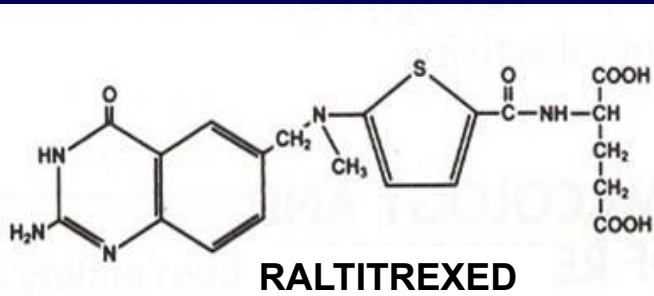

Figure 52-7. Mechanisms of tumor cell resistance to methotrexate.

TMP, thymidine monophosphate; dUMP, deoxyuridine monophosphate; FH₂, dihydrofolate; FH₄, tetrahydrofolate; Glu_n, polyglutamate.

NUOVI ANTIFOLATI



Pemetrexed disodium heptahydrate

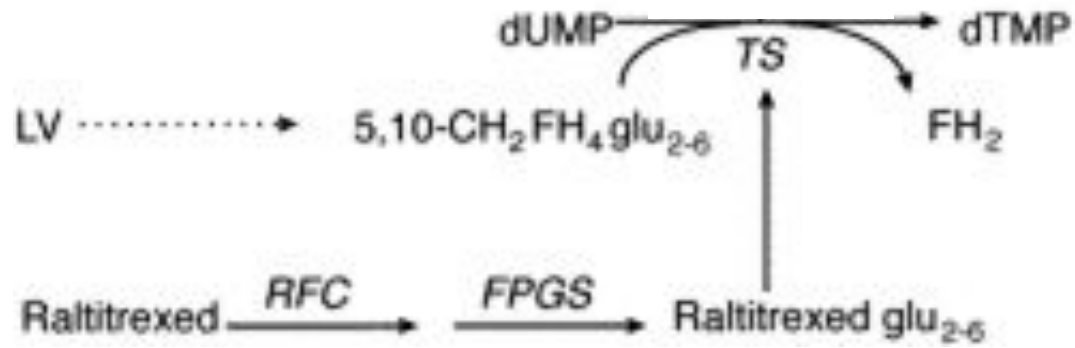

ANALOGHI DELLE NUCLEOBASI

E

DEI NUCLEOSIDI

ANALOGHI DELLE NUCLEOBASI E DEI NUCLEOSIDI

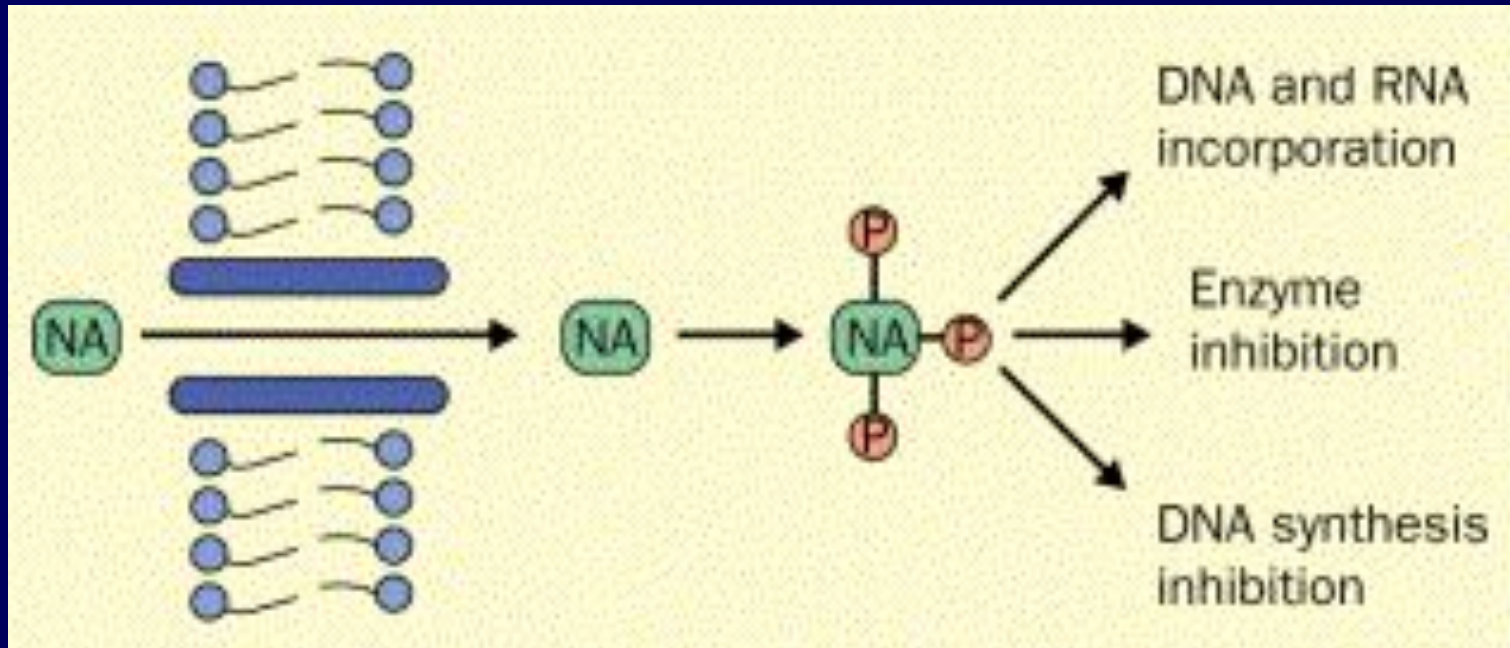

FLUOROPYRIMIDINE

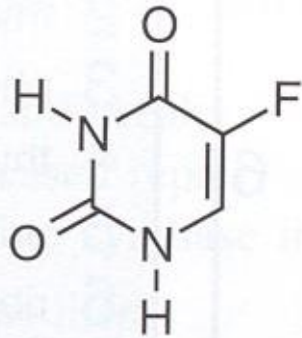

5-Fluorouracil

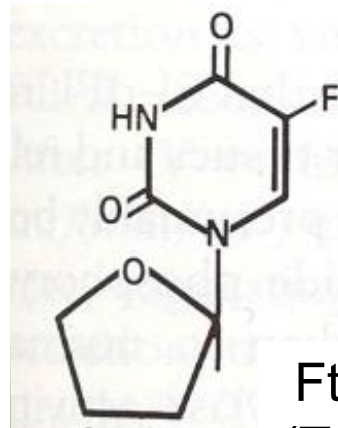

Ftorafur
(Tegafur)

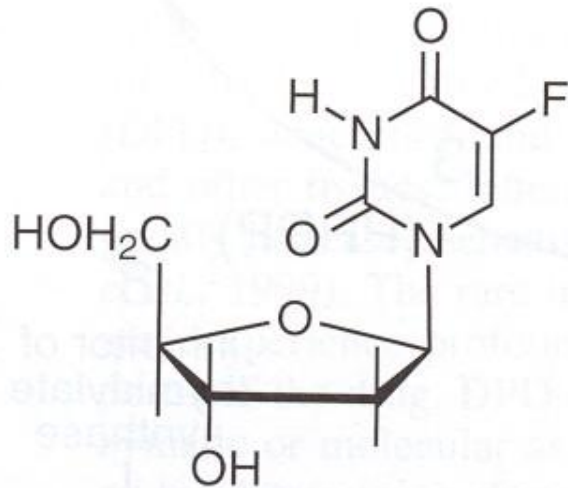

5-Fluorodeoxyuridine
(floxuridine)

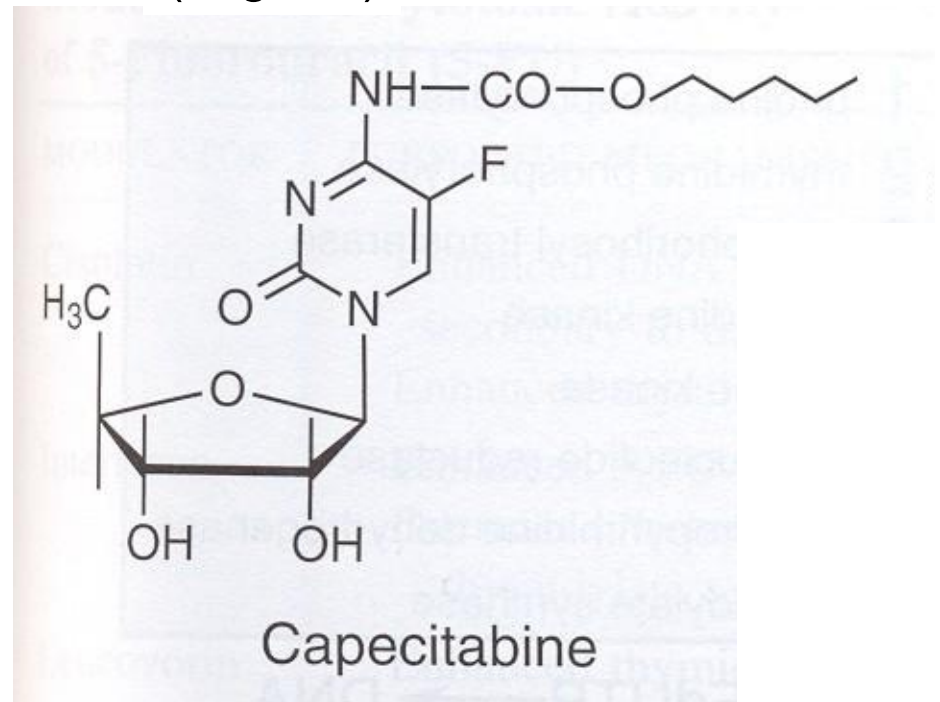

Capecitabine

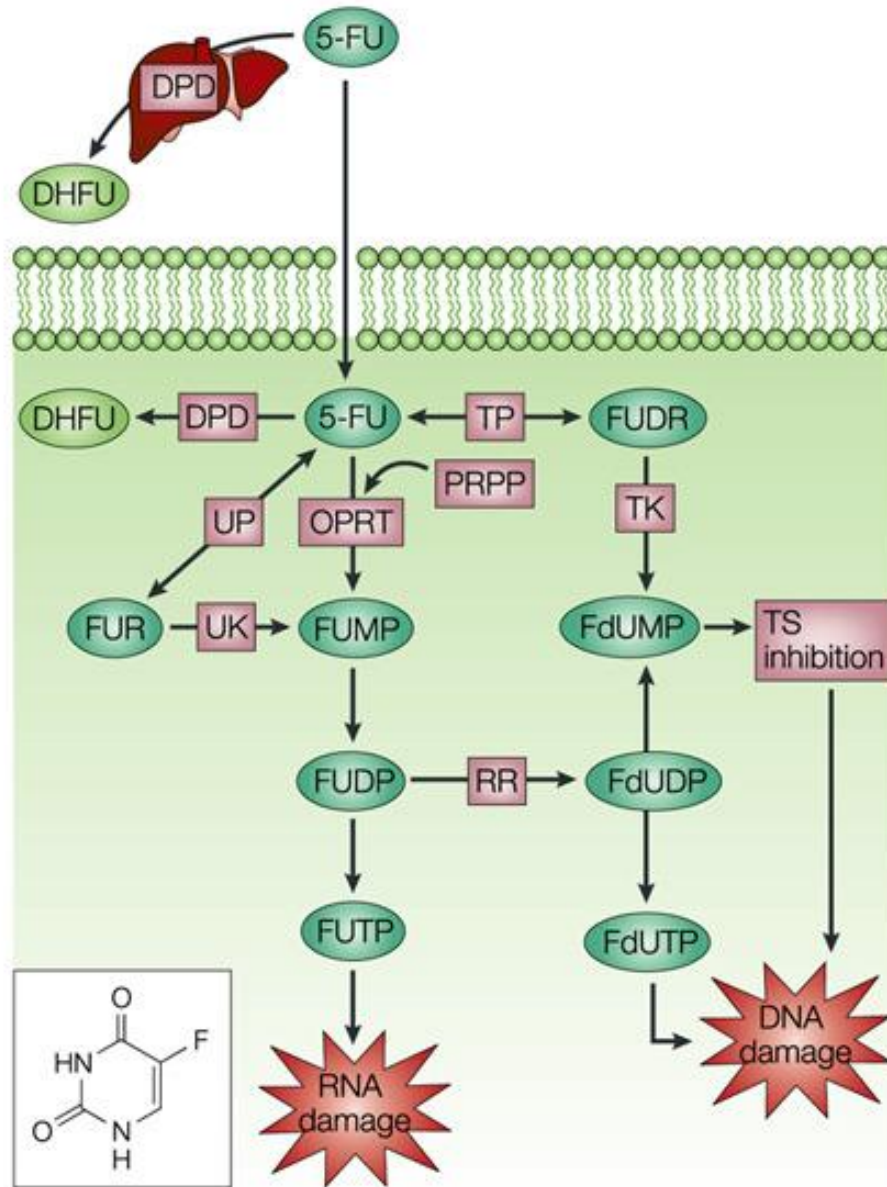

MECCANISMI D'AZIONE DEL 5-FLUOROURACILE

- 1) Inibizione della timidilato sintasi

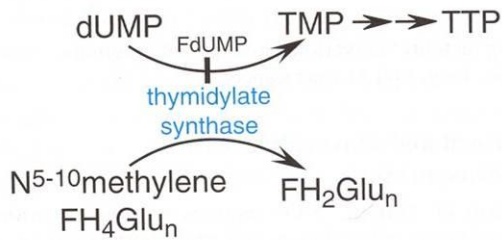

Other Actions of 5-FU nucleotides:

- Inhibition of RNA processing
- Incorporation into DNA

MECCANISMI D'AZIONE DEL 5-FLUOROURACILE

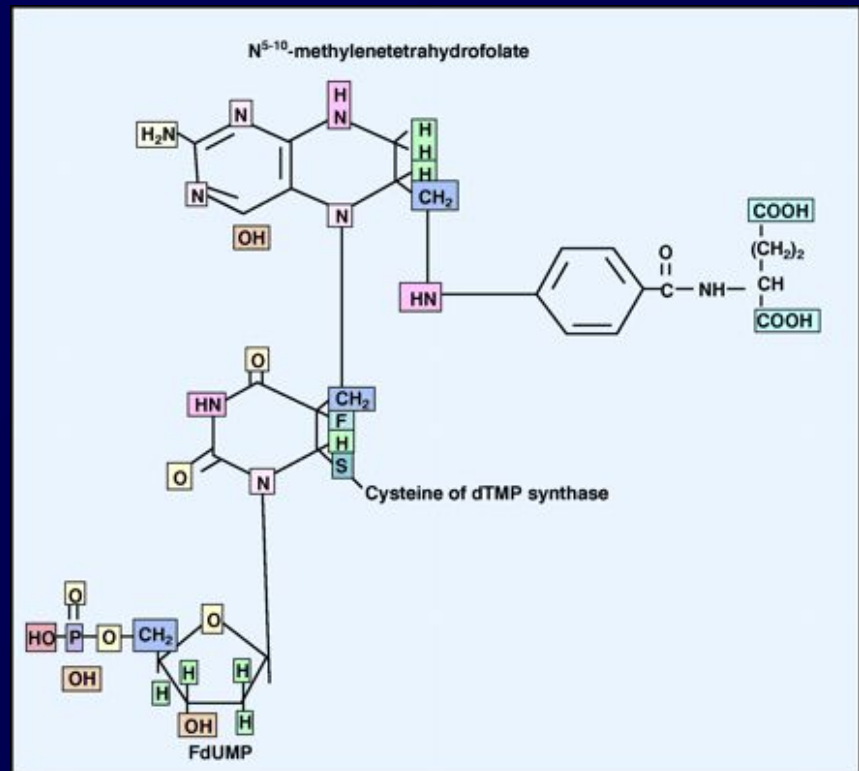
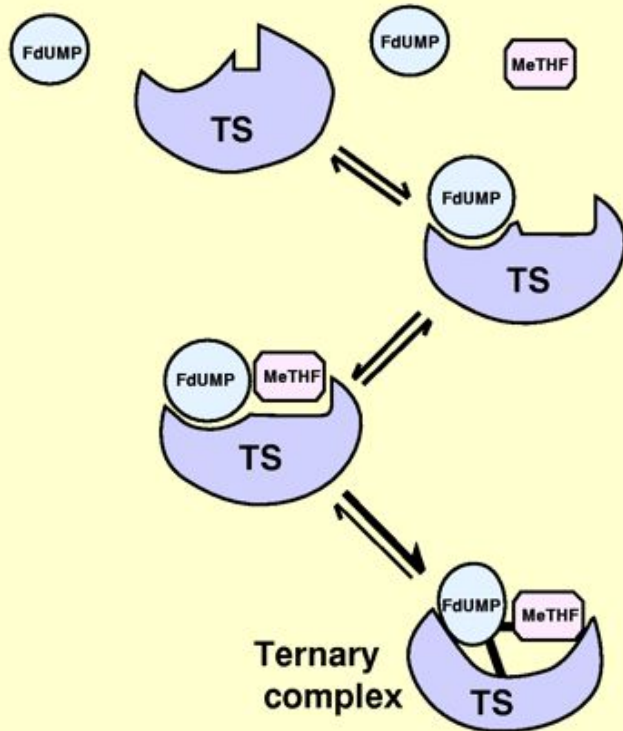

MECCANISMI D'AZIONE DEL 5-FLUOROURACILE

- 1) Inibizione della timidilato sintasi
- 2) Incorporazione di FUTP nel RNA

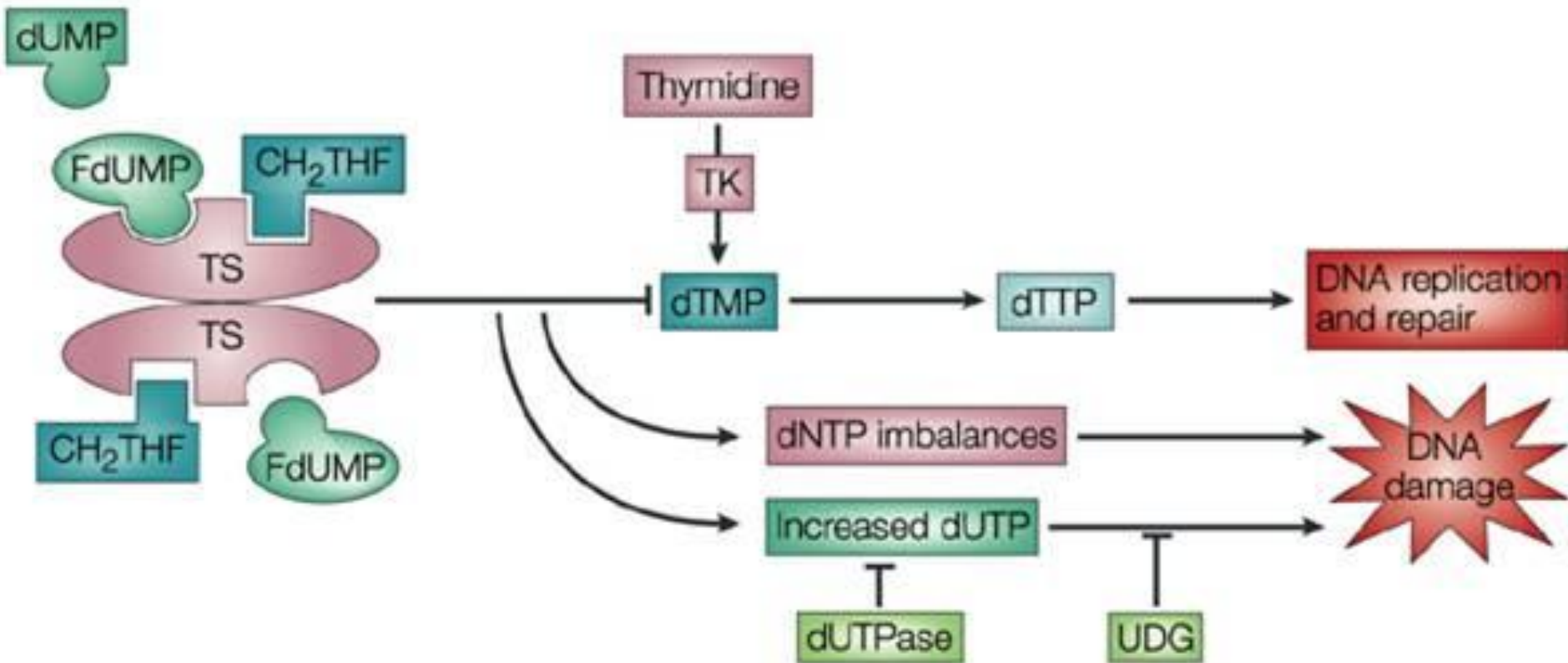

MECCANISMI D'AZIONE DEL 5-FLUOROURACILE

- 1) Inibizione della timidilato sintasi
- 2) Incorporazione di FUTP nel RNA
- 3) Incorporazione di FdUTP nel DNA

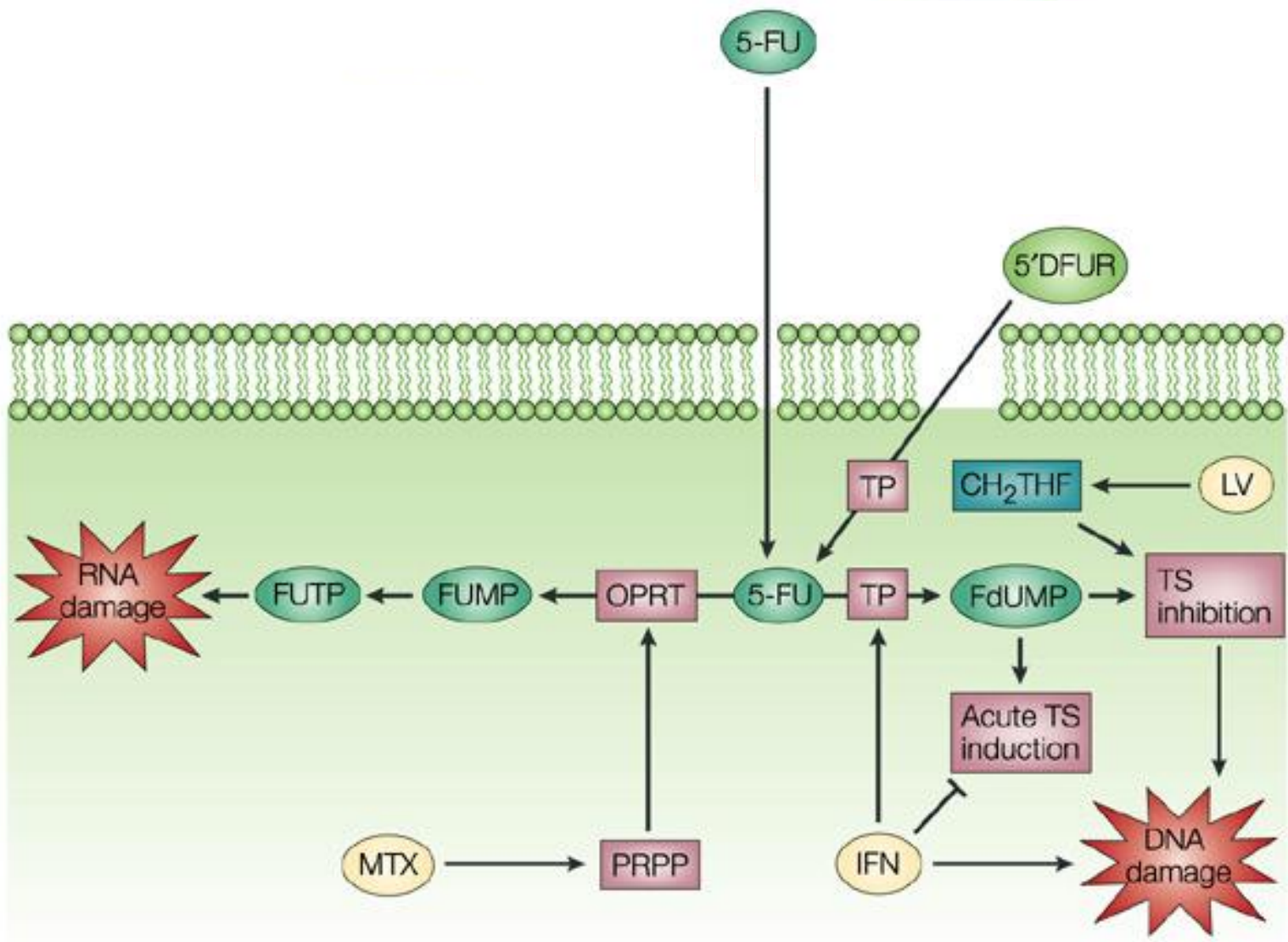

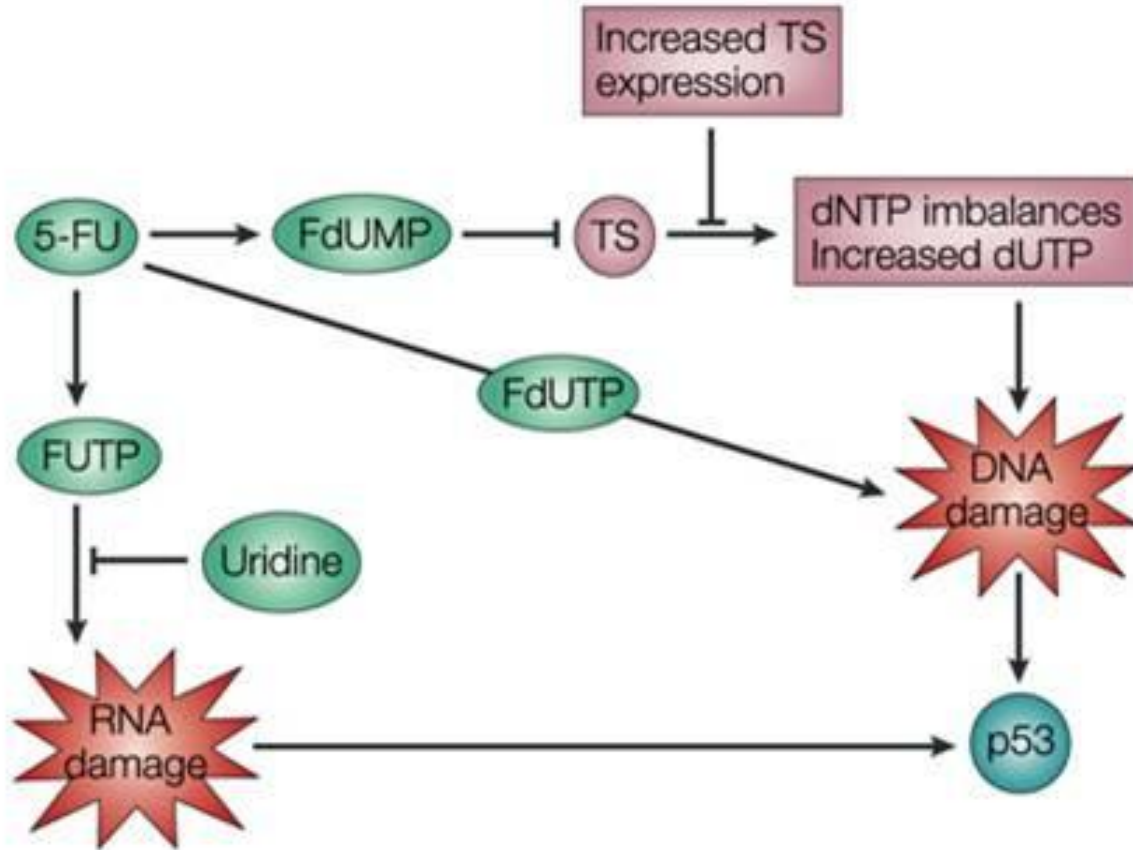

EFFETTI TOSSICI DEL 5FU

- EFFETTI GI: anoressia e nausea; stomatite e diarrea
- MIELOSOPPRESSIONE
- MANIFESTAZIONI NEUROLOGICHE
- TOSSICITÀ CARDIACA
- MANIFESTAZIONI CUTANEE

HAND-FOOT SYNDROME



MECCANISMI DI RESISTENZA AL 5FU

- PERDITA O ↓ ATTIVITÀ DEGLI ENZIMI ATTIVATORI
- ↓ PIRIMIDINA MONOFOSFATO CHINASI
- ↑ LIVELLI DELL'ENZIMA DEGRADATIVO DPD
- PRODUZIONE DI FORME ALTERATE DI TS

a DPD — Dihydropyrimidine dehydrogenase

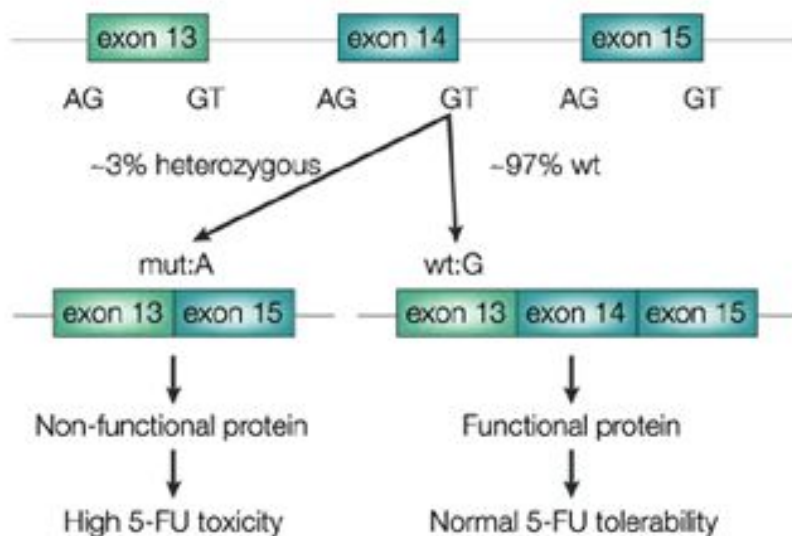

b Tumour

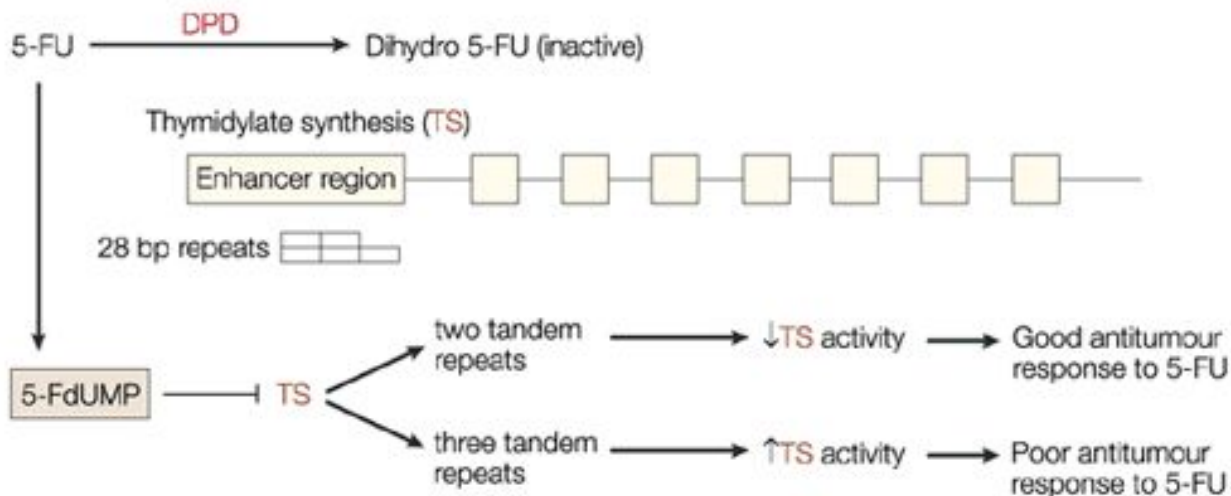

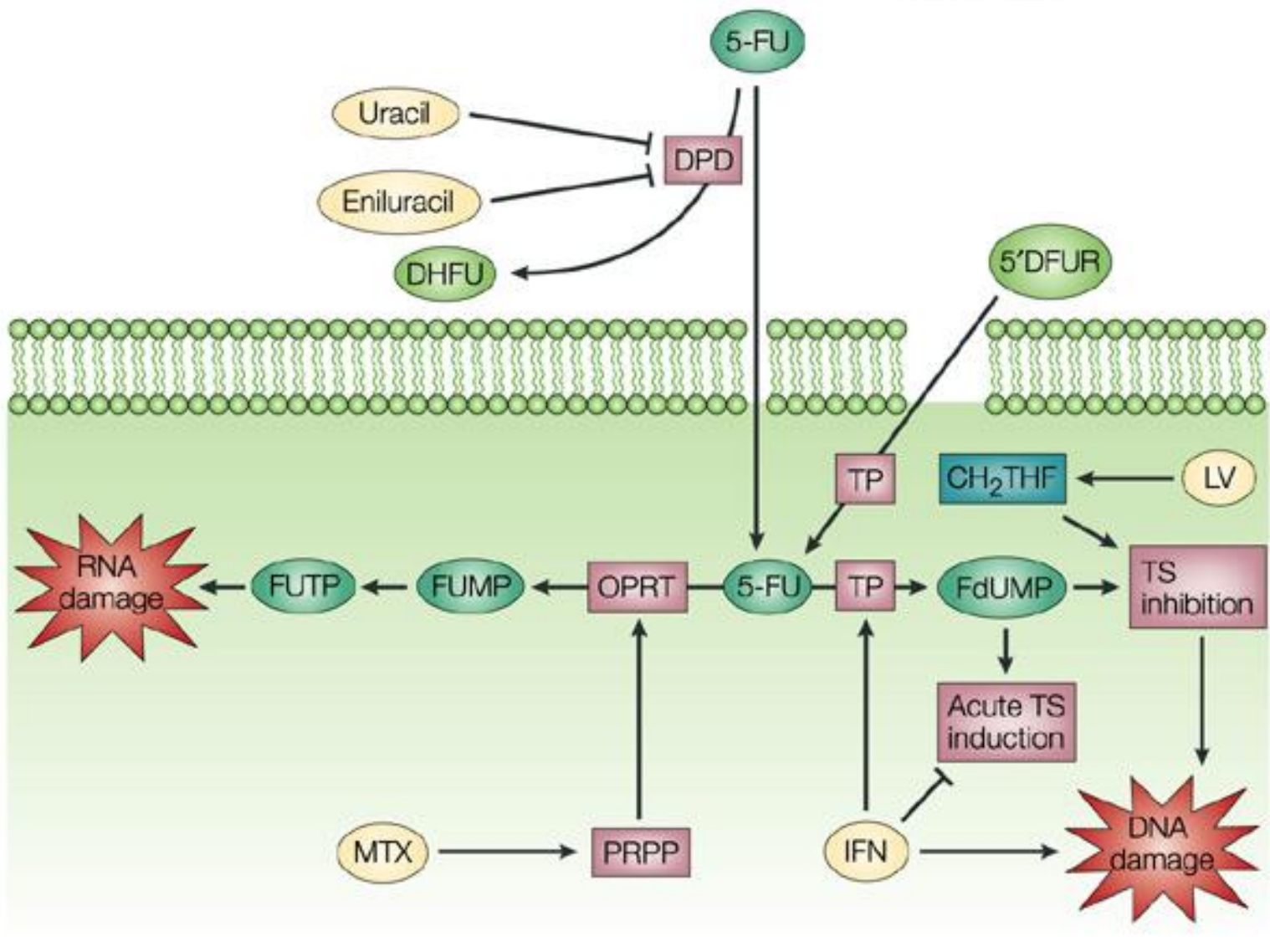

TRATTAMENTI COMBINATI CONTENENTI FLUOROPIRIMIDINE

UFT: ftorafur (profarmaco del 5FU)
uracile (inibitore della DPD)

S1: ftorafur (profarmaco del 5FU)
5-cloro-2,4-diidrossipiridina (inibitore della DPD)
potassio oxonato (inibitore della fosforibosil-
pirofosfato transferasi, riduce i sintomi
intestinali)

Figure 7-18. Metabolism of ftorafur.

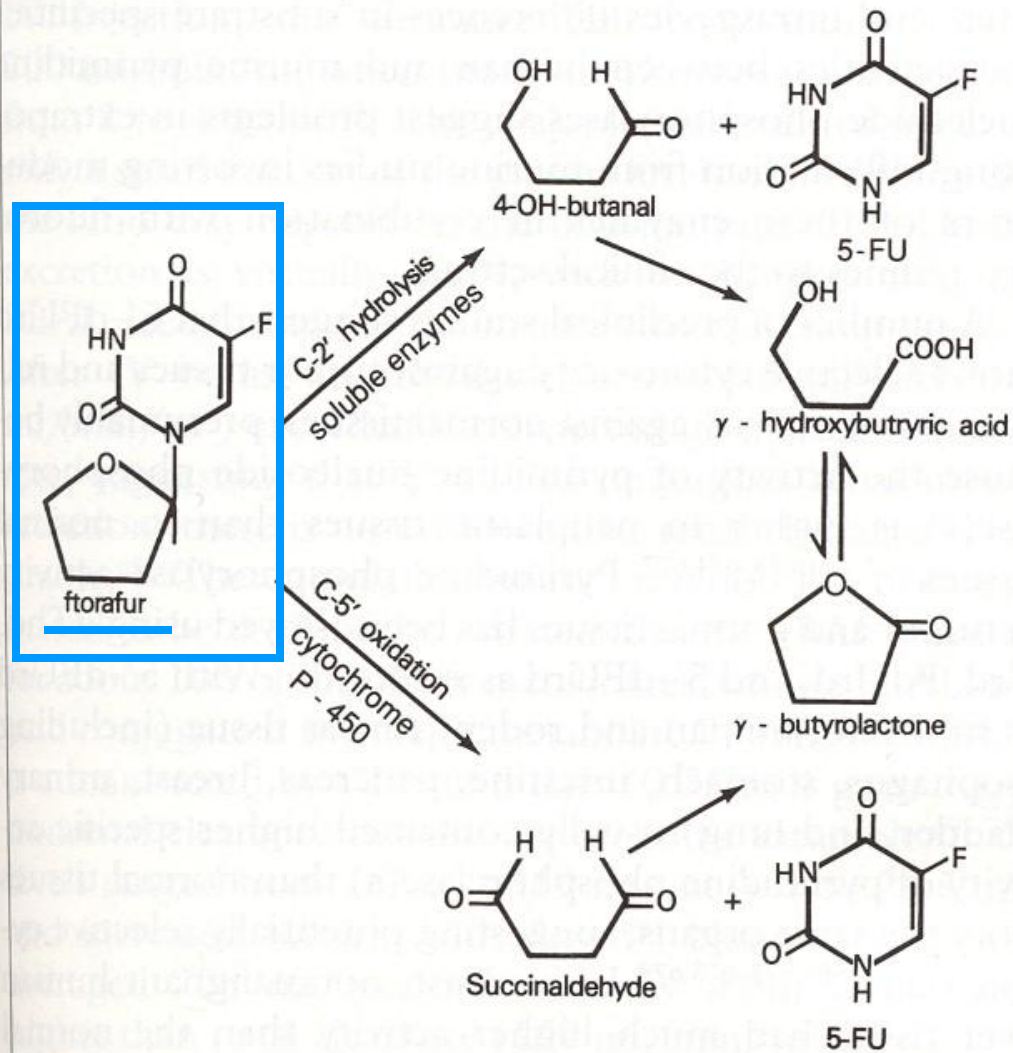

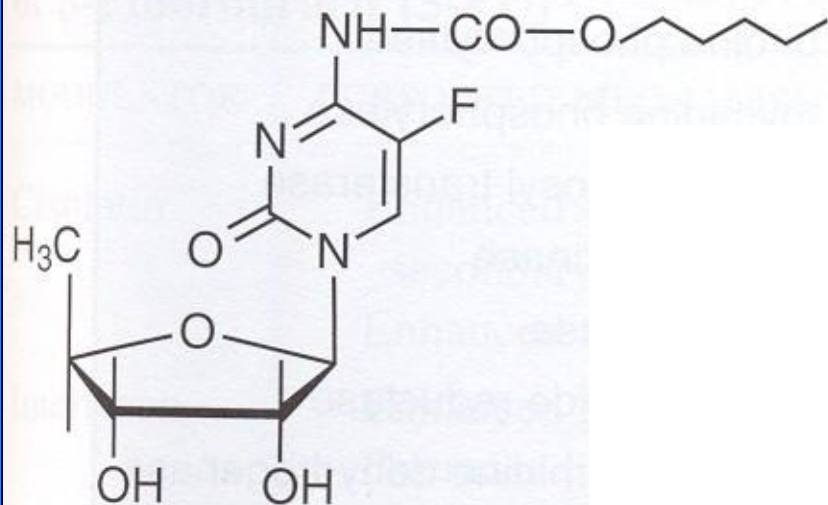

Capecitabine

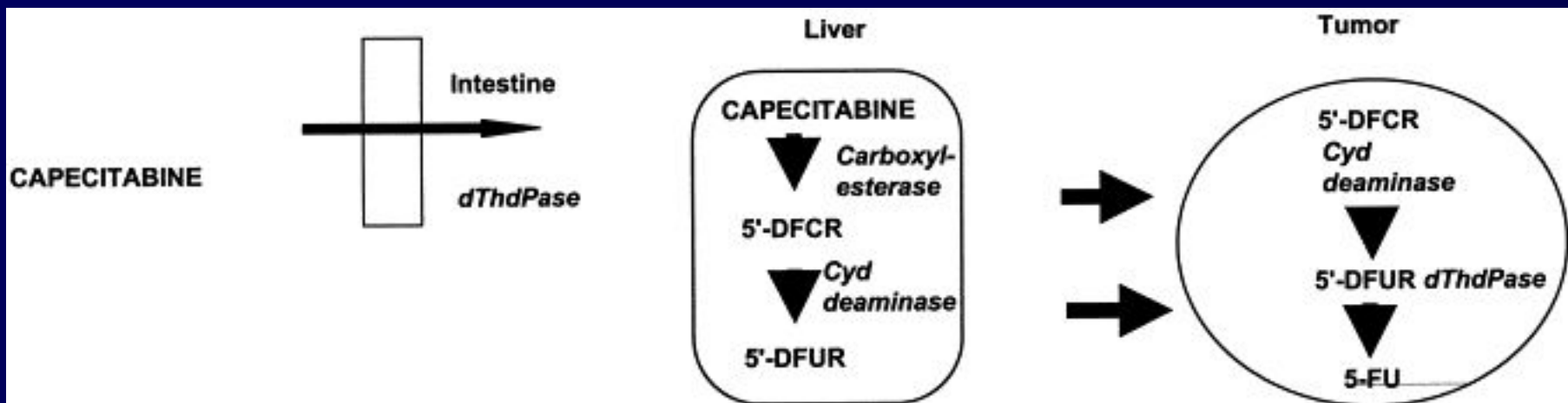

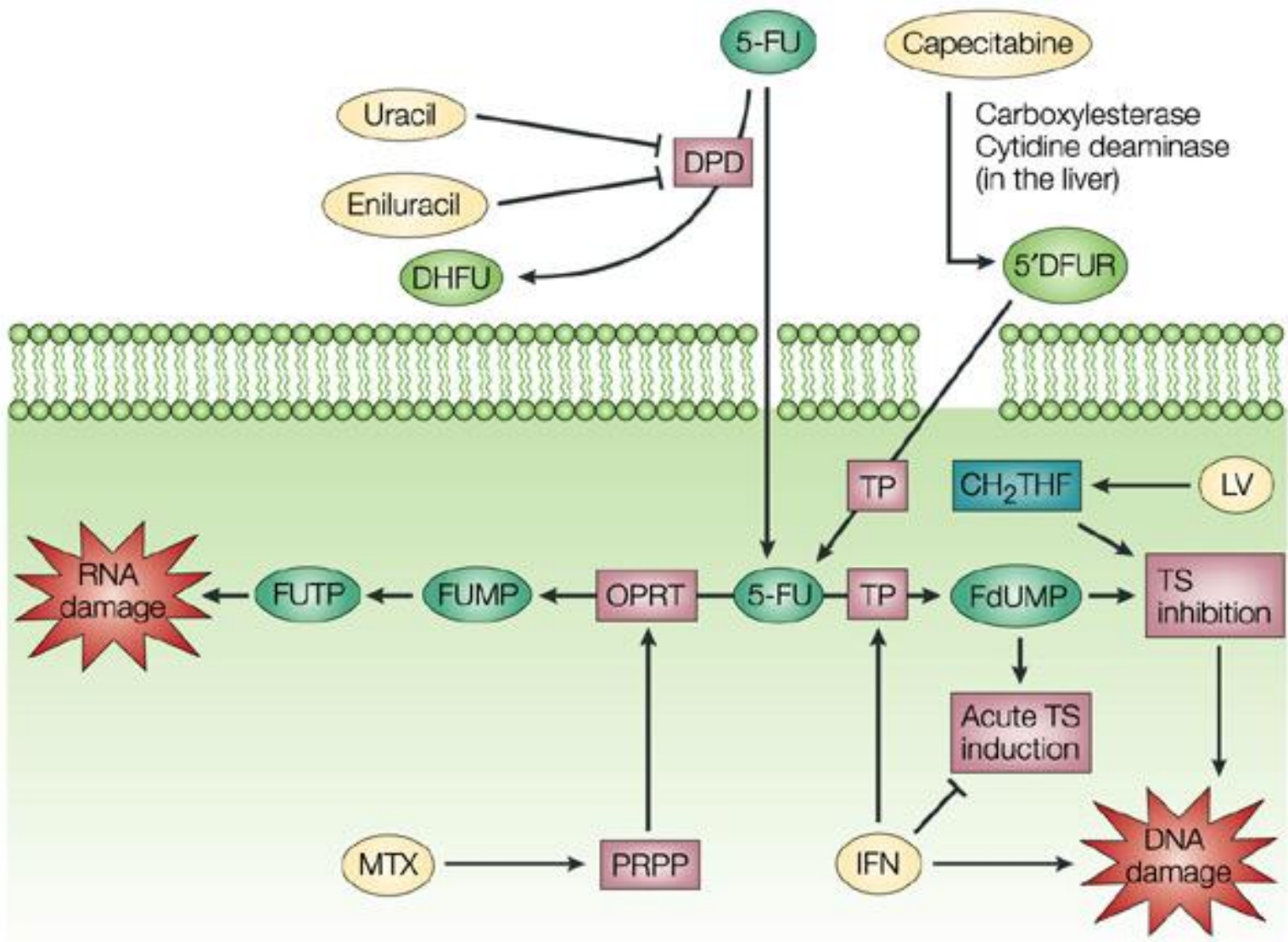

ANALOGHI DELLA CITOSINA

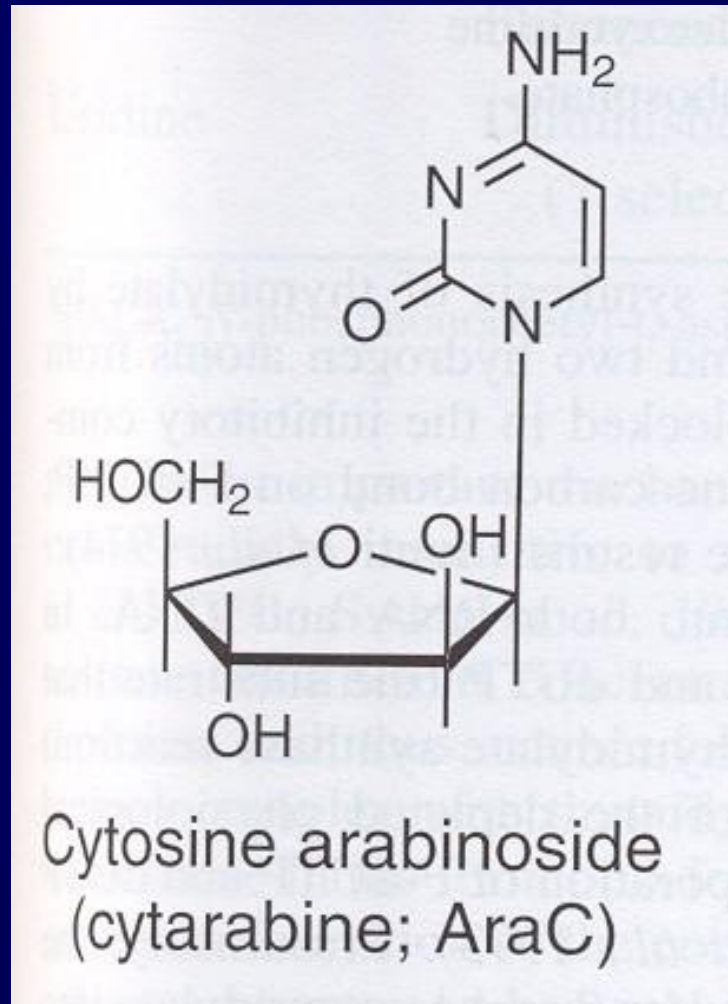

PATHWAYS PER L'ATTIVAZIONE/DEGRADAZIONE DI AraC

Figure 8-4. Metabolism of arabinosyl cytosine by tumor cells. The conversion of araUMP to a triphosphate has not been demonstrated in mammalian cells. d = deoxyribose; MP = monophosphate; DP = diphosphate; TP = triphosphate; NDP = nucleoside diphosphate.

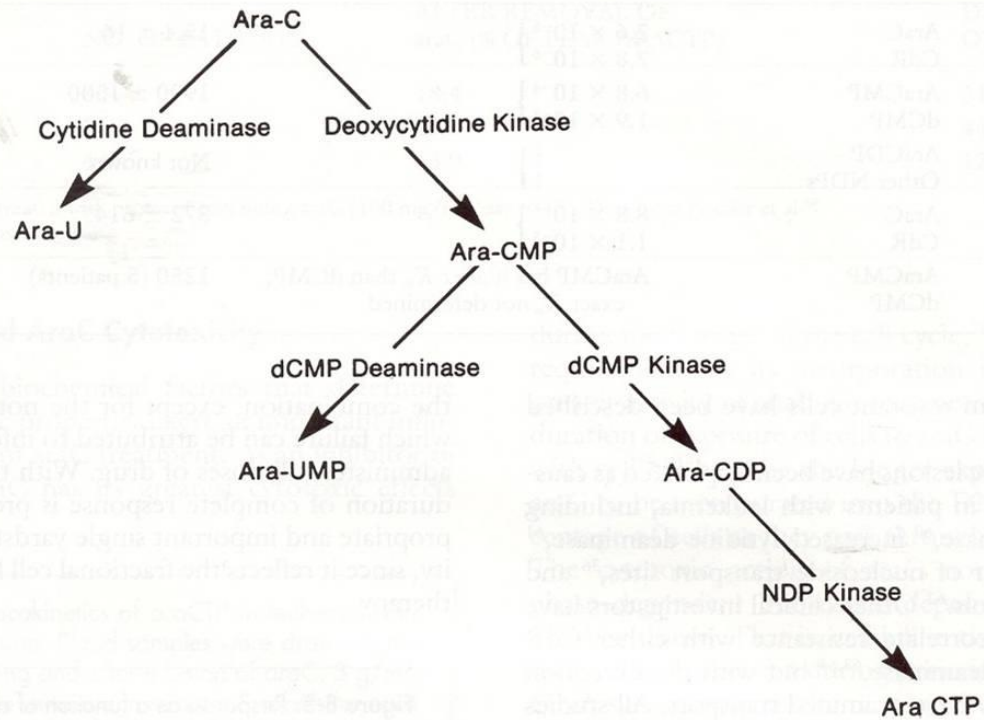

MECCANISMO D'AZIONE di AraC

- competizione con dCTP per l'incorporazione nel DNA
- inibizione della DNA polimerasi:
 - blocco dell'allungamento della catena di DNA
 - blocco della sintesi riparativa di DNA
- ripetizione di segmenti di DNA
 - aumentata possibilità di ricombinazione, crossover e amplificazione genica
- competizione con CDP-colina
 - inibizione della sintesi di glicoproteine e glicolipidi di membrana
- inibizione del trasferimento di galattosio, N-acetilglucosamina e acido sialico alle glicoproteine di membrana
- inibizione della sintesi di acido CMP-neuraminico

MECCANISMI DI RESISTENZA AGLI ANALOGHI DELLA CITOSINA

- ALTERAZIONE DELLE ATTIVITÀ RELATIVE DEGLI ENZIMI ATTIVATORI O DEGRADATIVE
- ALTERAZIONI A CARICO DEI TRASPORTATORI DI MEMBRANA
- ESPANSIONE DEL POOL CELLULARE DI dCTP
- SOVRAESPRESSIONE DEL GENE ANTIAPOPTOTICO *bcl-2*
- FOSFORILAZIONE DI FATTORI DI TRASCRIZIONE E/O FATTORI DI RISPOSTA A DANNI A CARICO DEL DNA

Figure 8-9. Interactions of thymidine and arabinosyl cytosine.

1. Thymidine triphosphate inhibits dCTP synthesis

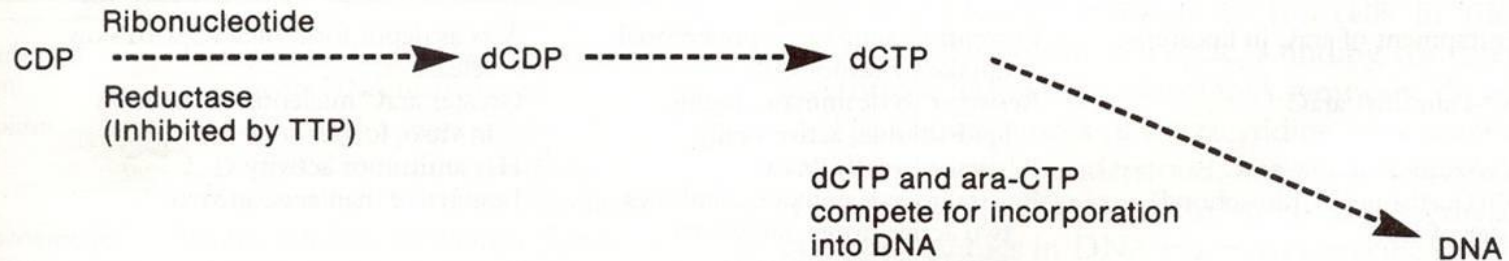

2. Reduction in dCTP levels enhances ara-CTP formation and incorporation into DNA

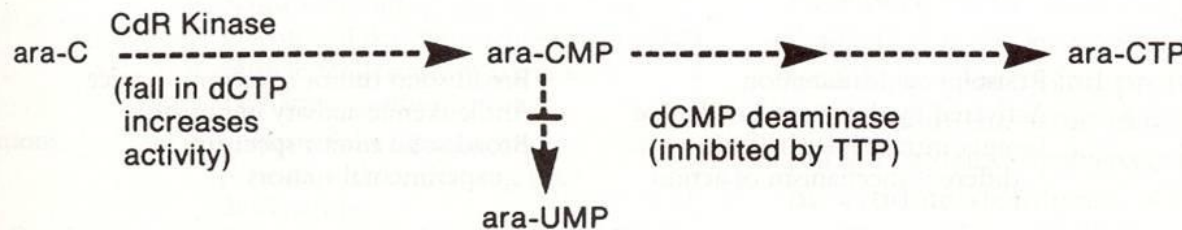

EFFETTI TOSSICI DEGLI ANALOGHI DELLA CITOSINA

- MIELOSOPPRESSIONE
- EFFETTI GI
- MUCOSITE
- LIEVE DISFUNZIONE EPATICA (reversibile)
- POLMONITE

STOMATITE
DA AraC



ANALOGHI DELLA CITOSINA

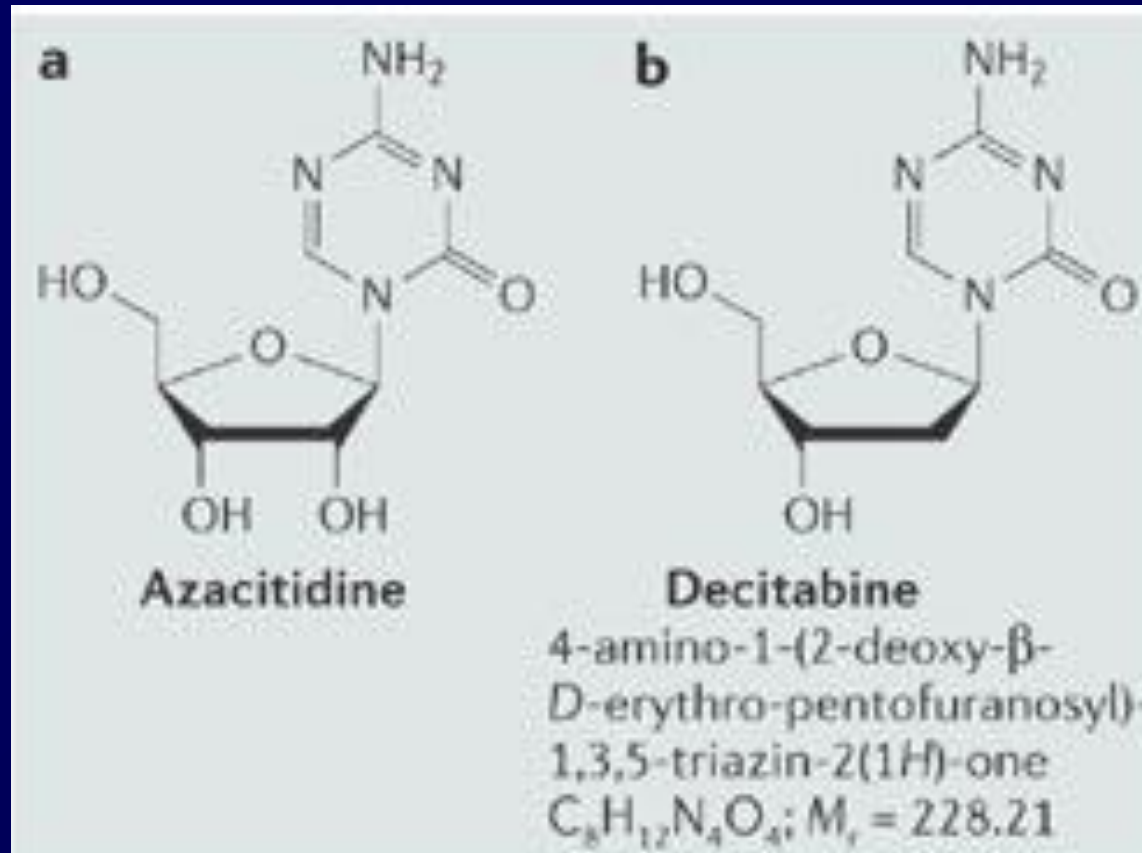

inibitori della metilazione del DNA

approvati per la terapia delle sindromi

mielodisplastiche

Modificazioni Epigenetiche e Cancro

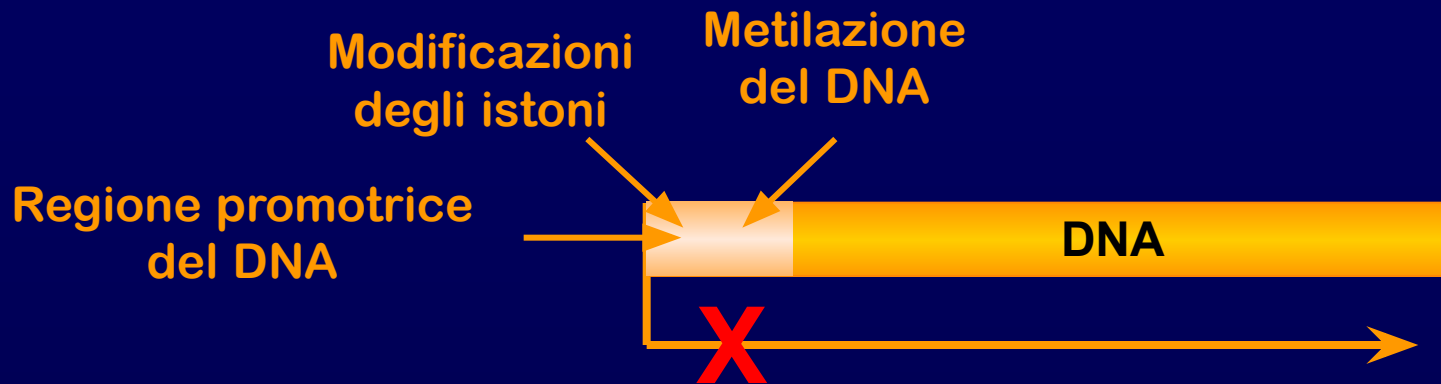

Blocco della trascrizione del RNA
Silenziamento epigenetico di geni oncosoppressori

Metilazione del DNA

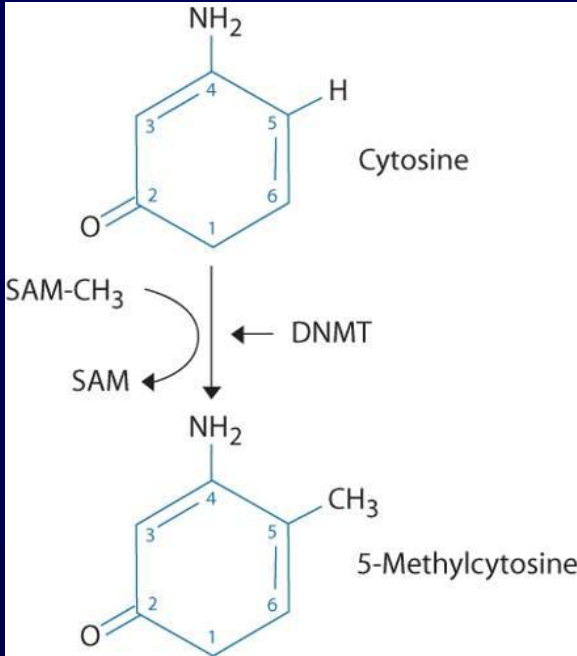

METILAZIONE DEL DNA

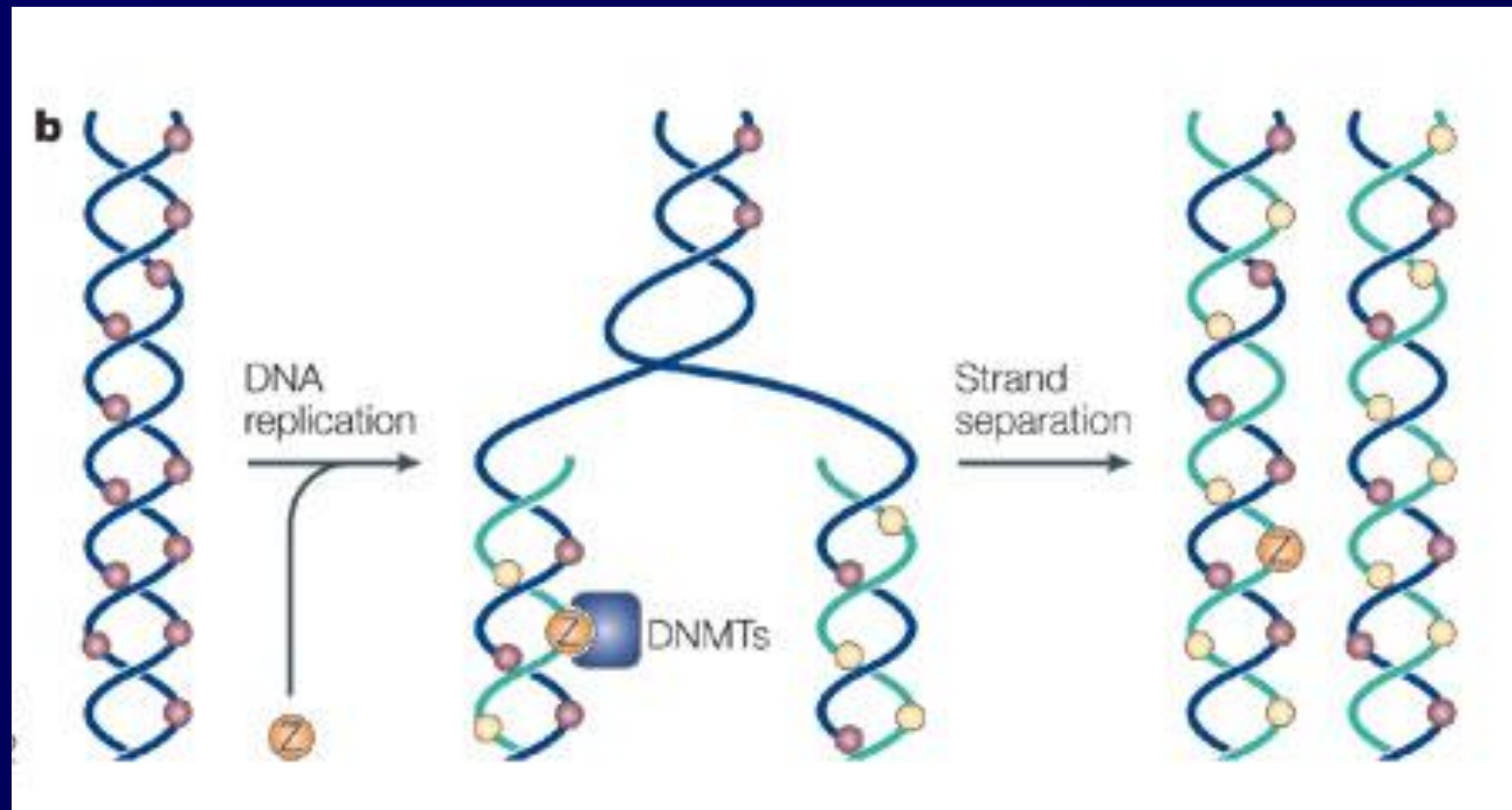

ANALOGHI DELLA CITOSINA

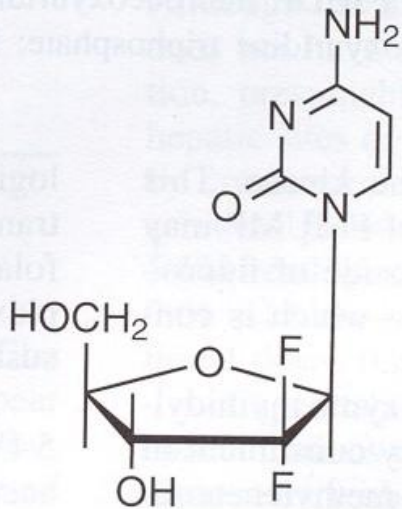

2', 2'-Difluorodeoxycytidine
(gemcitabine)

competizione tra dFdCTP e dCTP

- inibizione DNA polimerasi

inibizione della ribonucleotide reductasi

incorporazione di dFdCTP nel DNA

- Blocco dell'allungamento della

catena dopo l'incorporazione di un

ulteriore nucleotide □ elusione dei

sistemi di riparazione del DNA

attiva anche su cellule in fase non-S

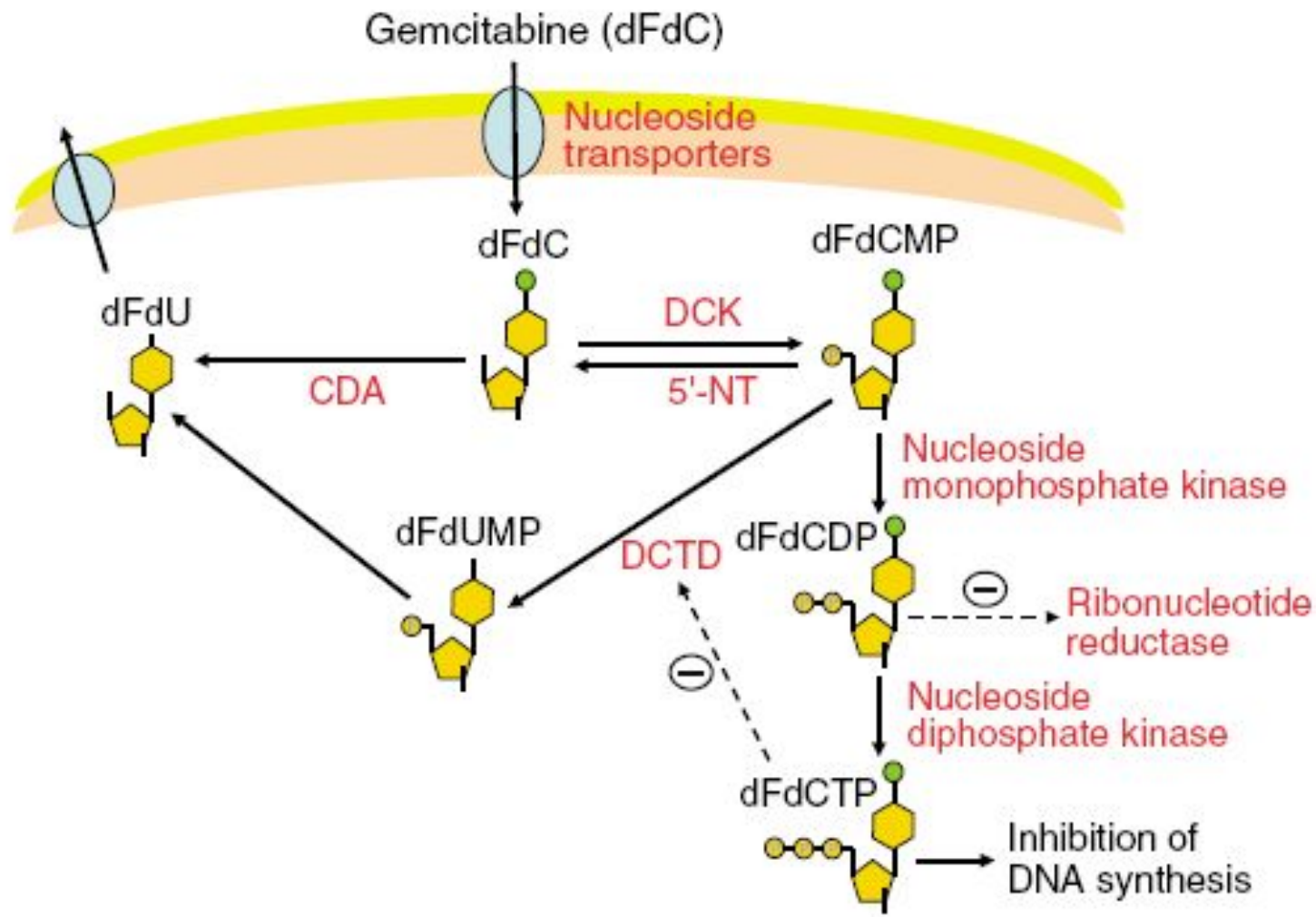

Gemcitabine (dFdC)

Nucleoside transporters

dFdC

dFdCMP

dFdU

DCK

CDA

5'-NT

Nucleoside monophosphate kinase

dFdUMP

dFdCDP

Ribonucleotide reductase

Nucleoside diphosphate kinase

DCTD

dFdCTP

Inhibition of DNA synthesis

VIA DI RECUPERO DELLE BASI PURINICHE

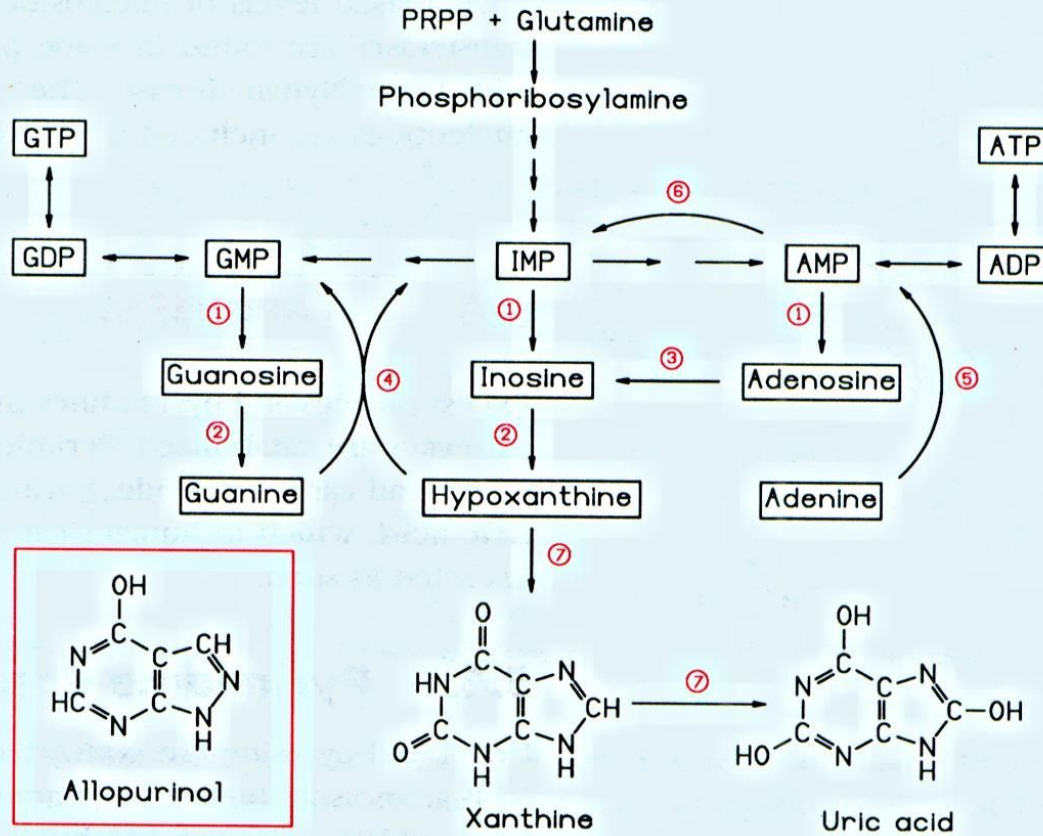

1. 5'-Nucleotidase
2. Nucleoside phosphorylase
3. Adenosine deaminase
4. Hypoxanthine-guanine-phosphoribosyl transferase (HGPRTase)

5. Adenine phosphoribosyl transferase
6. AMP deaminase
7. Xanthine oxidase

ANALOGHI DELLA GUANINA

Figure 9-1. Structure of the naturally occurring purine guanine and related antineoplastic agents 6-mercaptopurine, 6-thioguanine, and azathioprine.

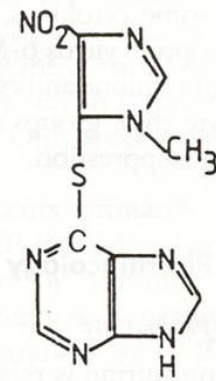

Azathioprine

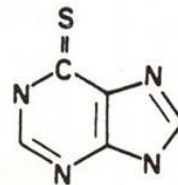

6-Mercaptopurine

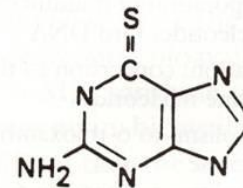

6-Thioguanine

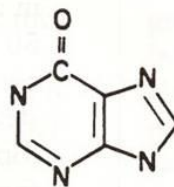

Hypoxanthine

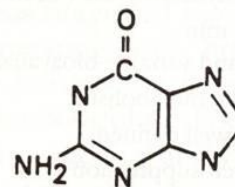

Guanine

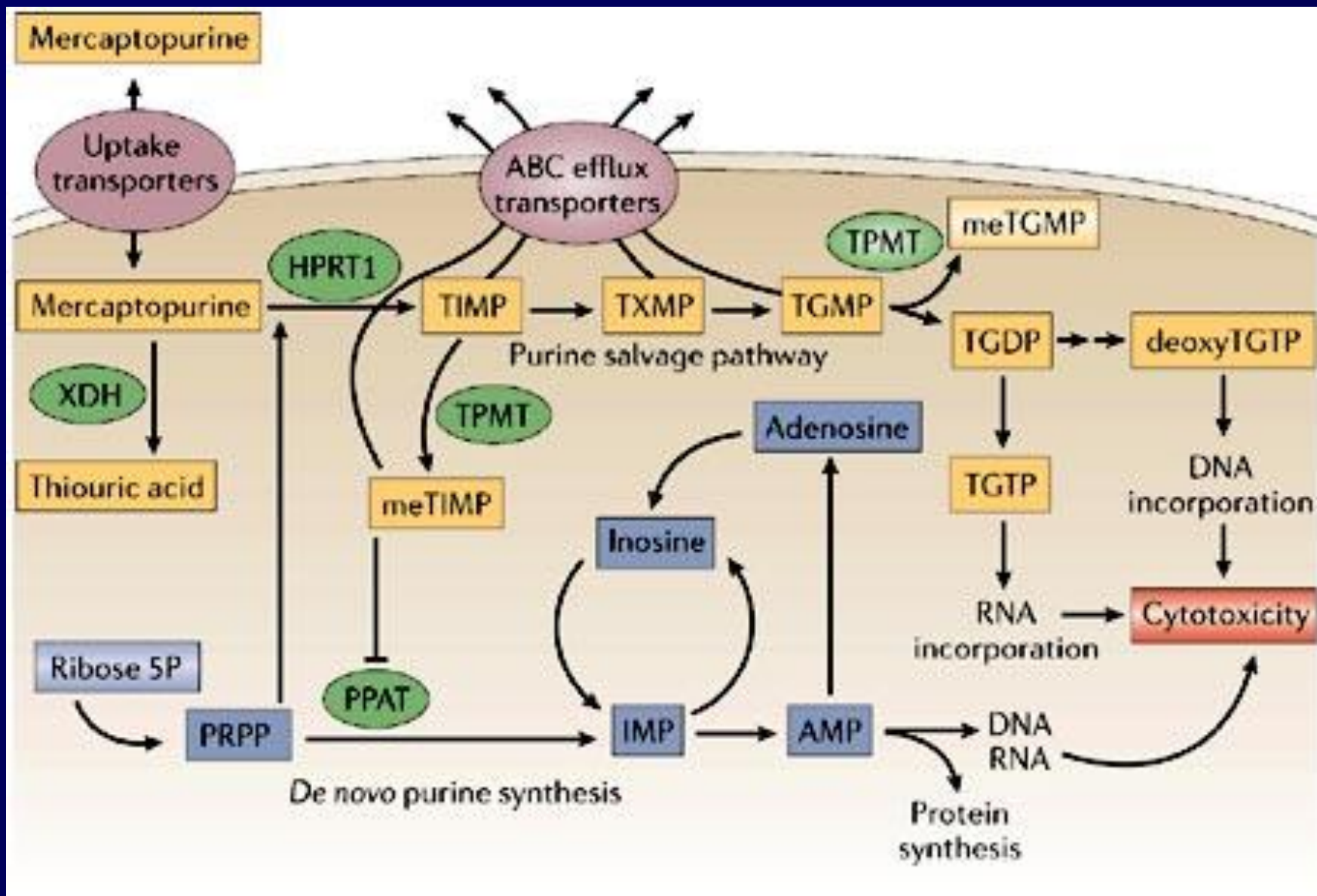

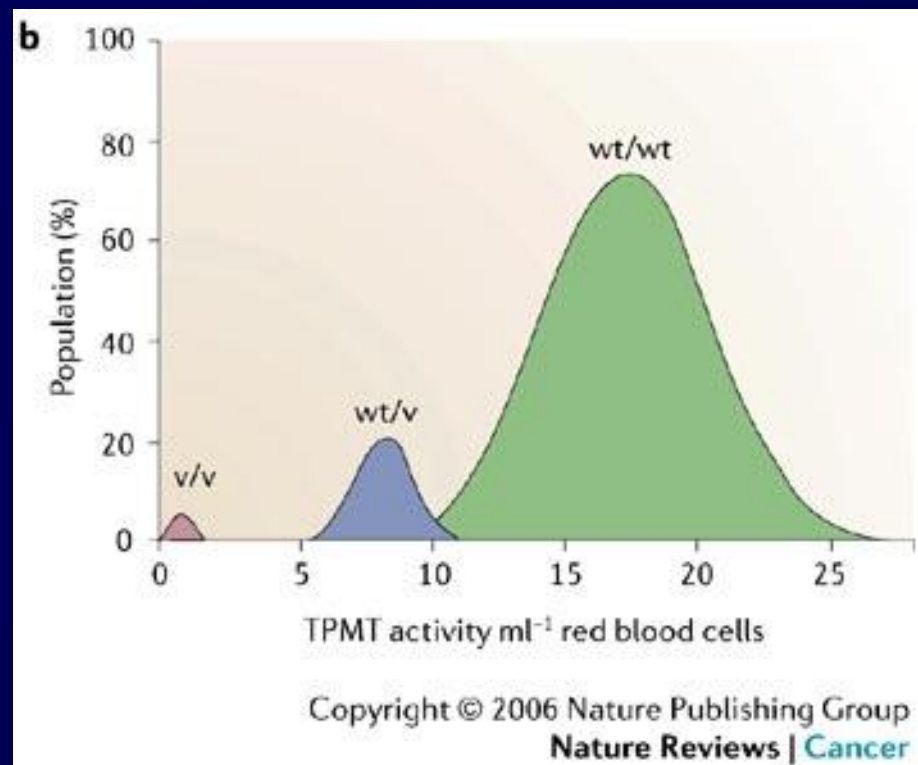
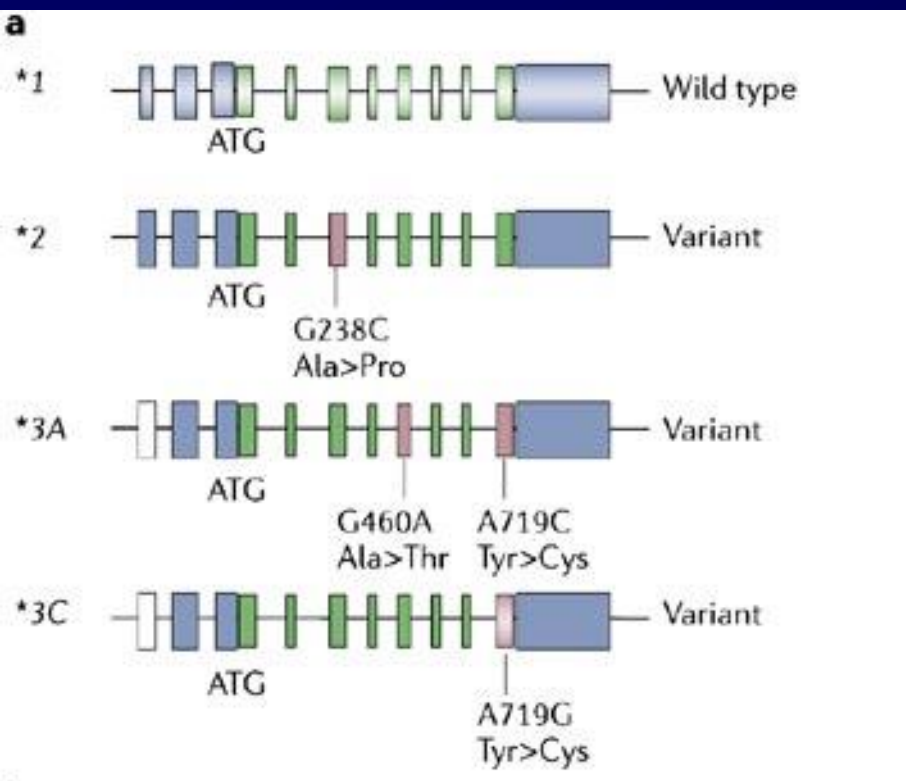

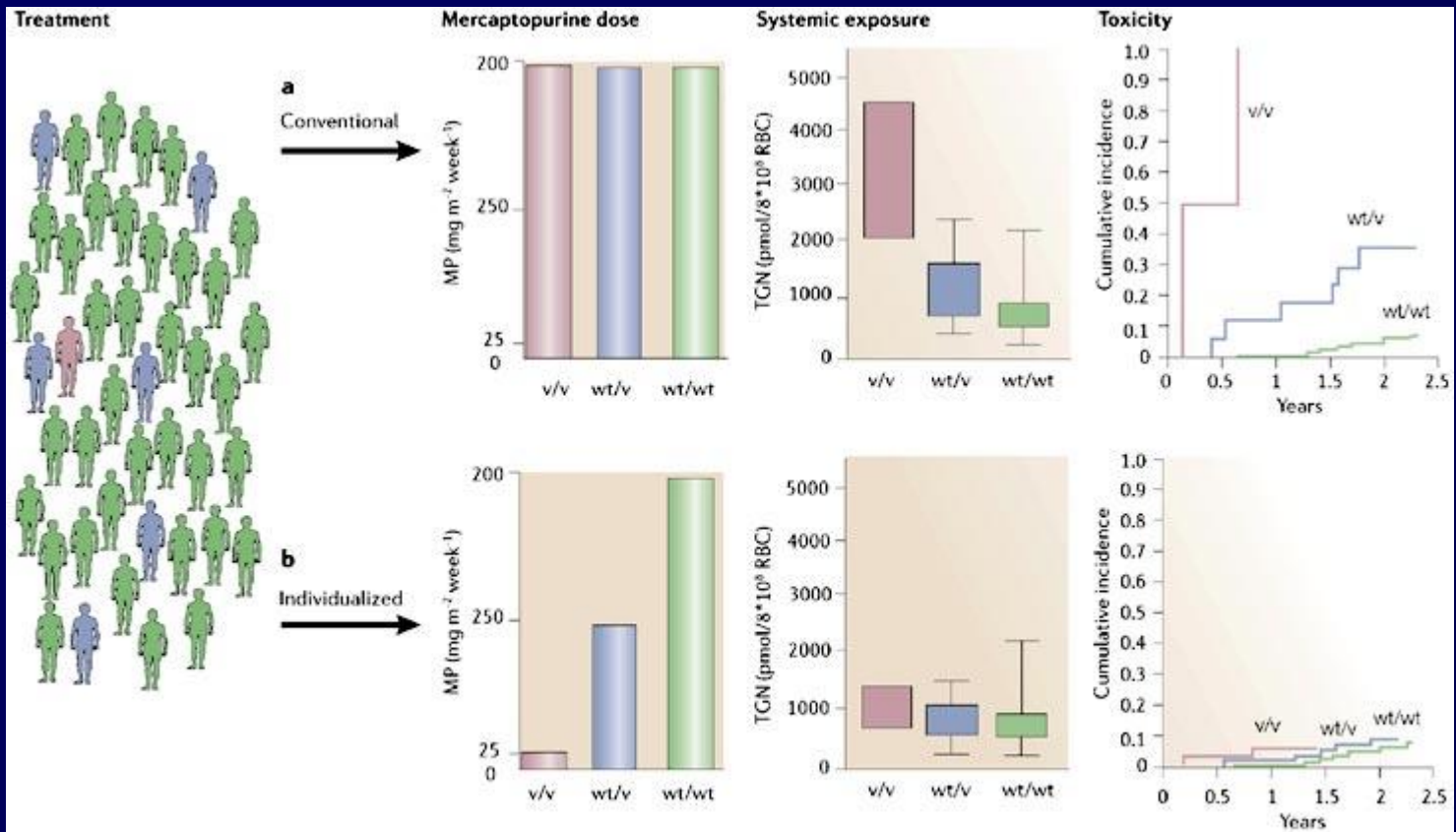
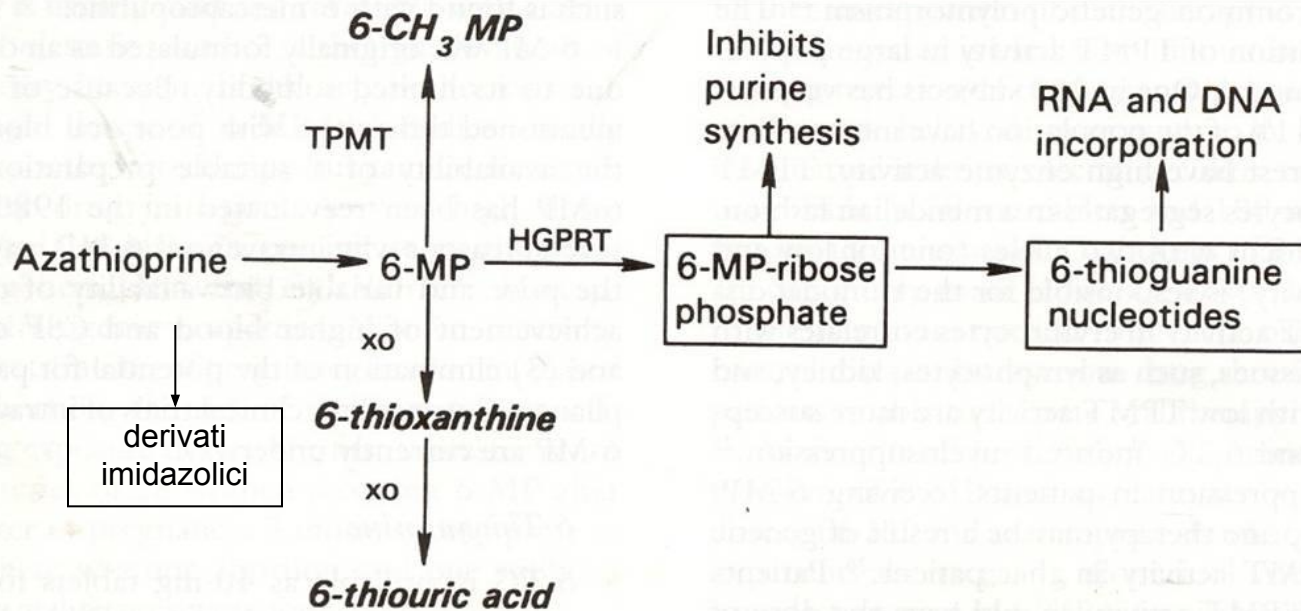
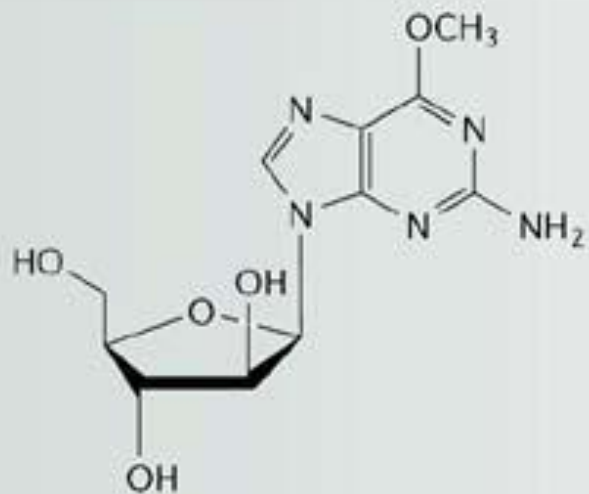

Figure 9-2. Mechanism of activation and catabolism of azathioprine and 6-mercaptopurine. Active metabolites are indicated by surrounding boxes. Inactive (or less active) metabolites are indicated by italic print. TPMT = thiopurine methyltransferase; xo = xanthine oxidase; HGPRT = hypoxanthine-guanine phosphoribosyltransferase.





Nelarabine

2-amino-9-α-D-arabinofuranosyl-6-methoxy-9H-purine;

$C_{11}H_{15}N_5O_5$; $M_r = 297.27$; CAS number: 121032-29-9



Adenosine deaminase

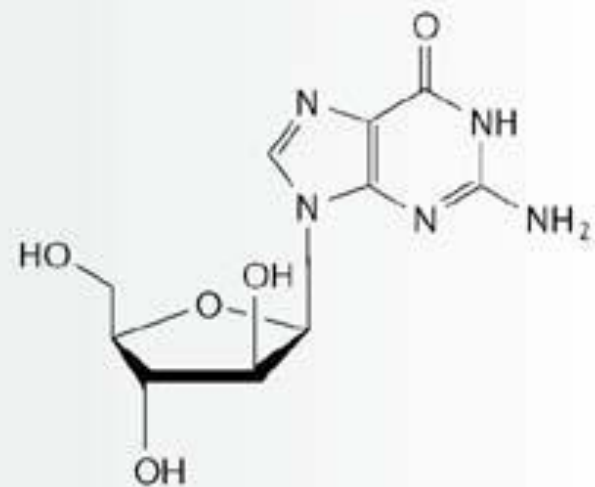

ara-G

MECCANISMI DI RESISTENZA AGLI ANALOGHI DELLA GUANINA

- PERDITA O ↓ ATTIVITÀ DELL' ENZIMA HGPRT
- ↓ TRASPORTO ATTRAVERSO LA MEMBRANA PLASMATICA
- ↑ DELLA VELOCITÀ DI DEGRADAZIONE
- ALTERATA EFFICIENZA DEGLI ENZIMI CHE RIPARANO IL DNA
- ↑ DELL'ATTIVITÀ DELLA MRP5

ANALOGHI DELL' ADENOSINA

Figure 9-3. Structure of adenosine and the adenosine analogues fludarabine (9- β -arabinofuranosyl-2-fluoroadenosine monophosphate, F-araAMP), pentostatin (2-deoxycytosine), and cladribine (2CdA, 2-chlorodeoxyadenosine).

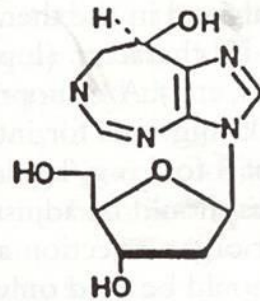

pentostatin

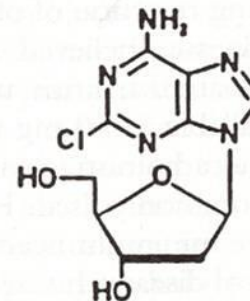

cladribine

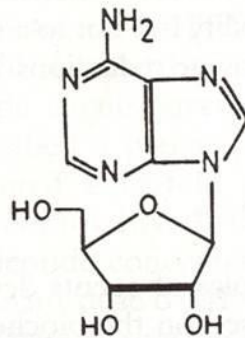

adenosine

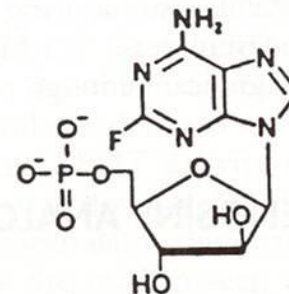

fludarabine
phosphate

Deficit o inibizione dell'enzima adenosina deaminasi (ADA)



Accumulo di dAdenosina e dATP



Inibizione a feedback della ribonucleotide reduttasi

+

Inibizione della S-adenosil-omocisteina idrolasi

Inibizione sintesi e riparazione del DNA

Inibizione delle reazioni di metilazione



DERIVATI DELLA DESOSSIADENOSINA

Figure 9-4. Activation of fludarabine.

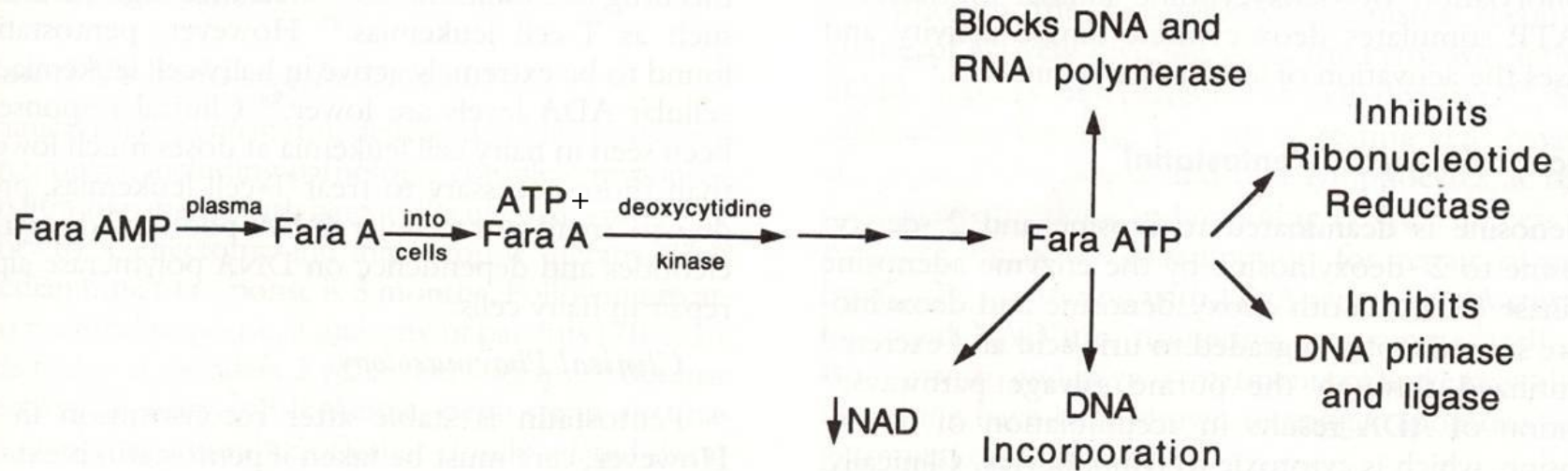

DERIVATI DELLA DESOSSIADENOSINA

Figure 9-5. Activation of 2-chlorodeoxyadenosine (2CdA or cladribine).

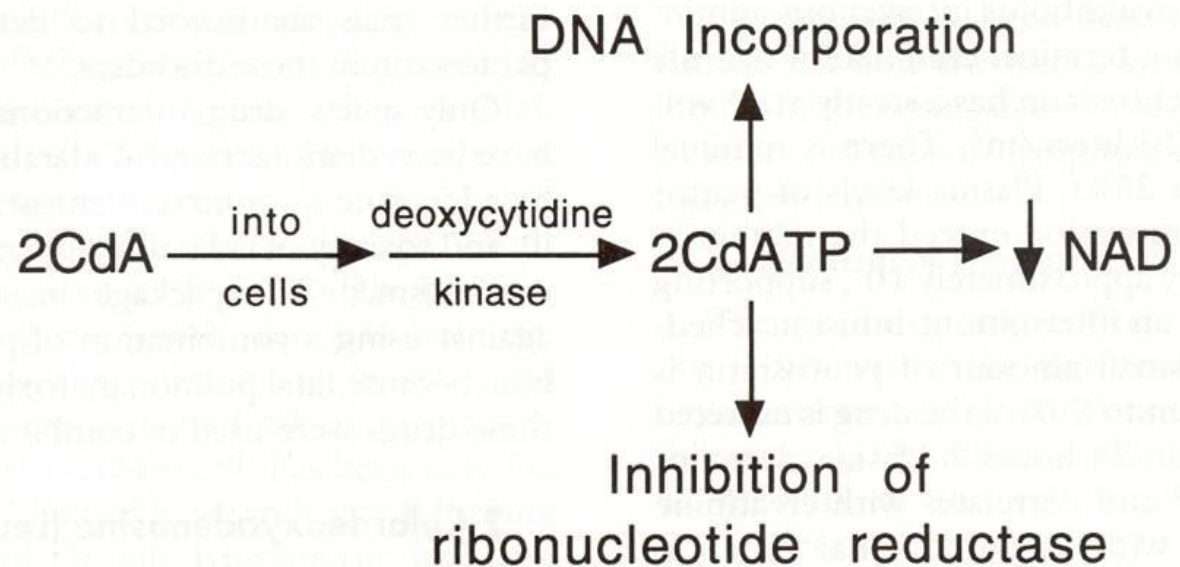

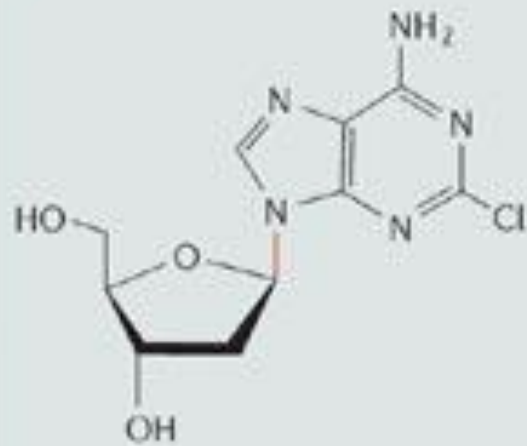

Cladribine

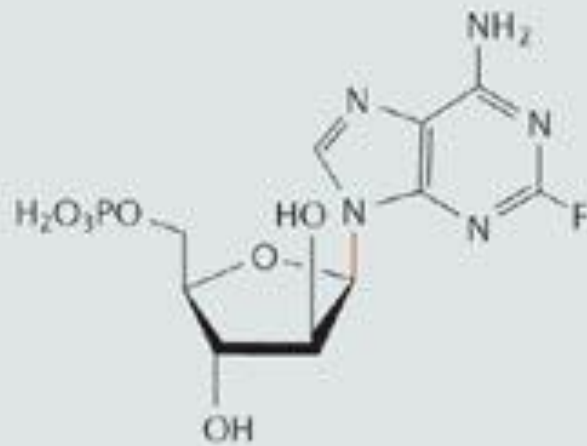

Fludarabine phosphate

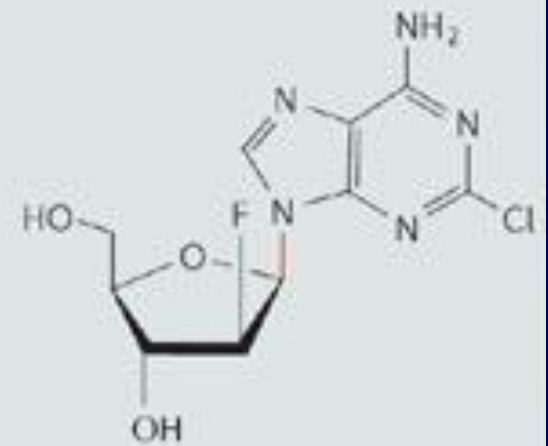

Clofarabine

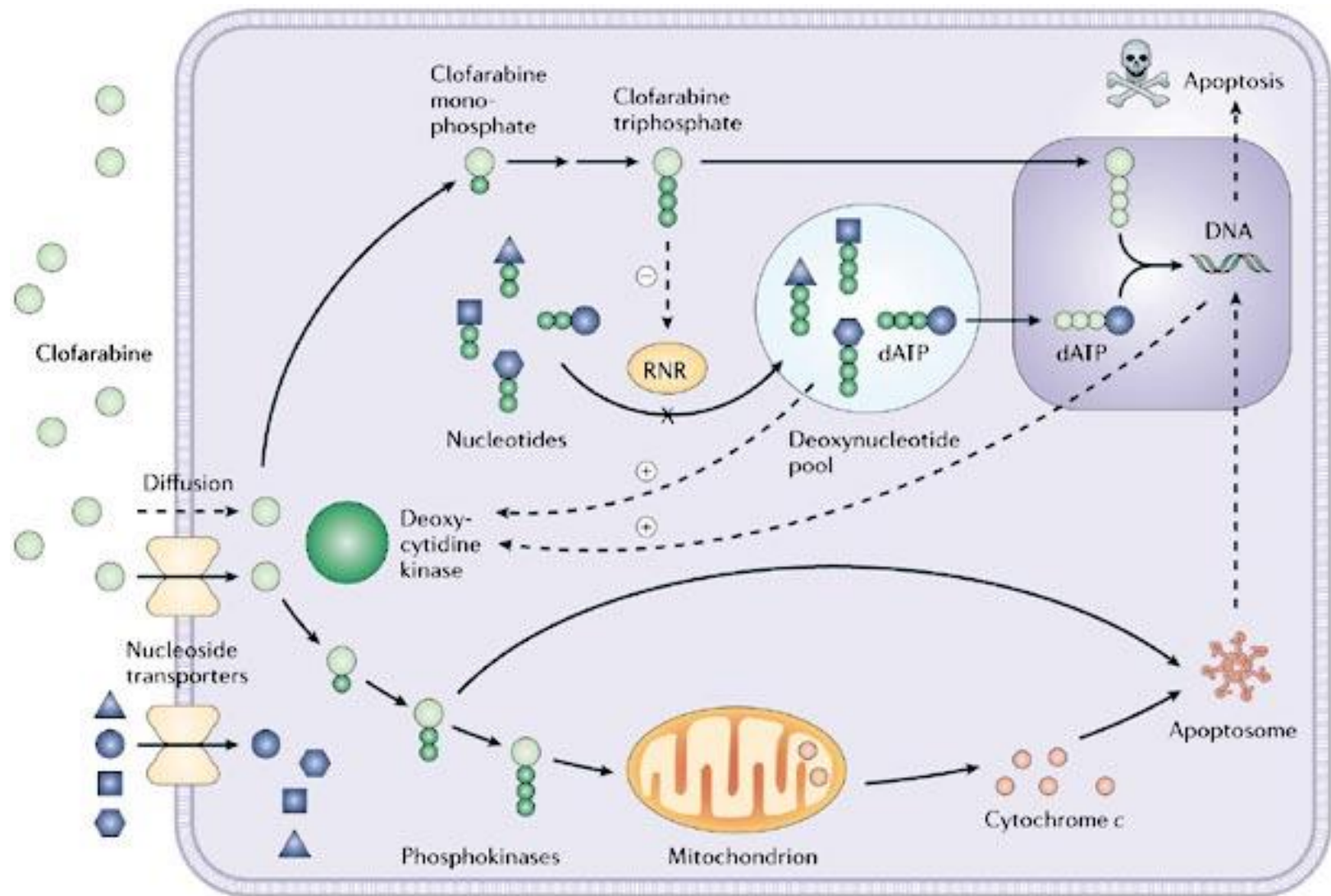

Parameter	Clofarabine	Fludarabine	Cladribine
Phosphorylated by dCK	++++	+	++++
dCK rate-limiting enzymatic step	No	Yes	No
Major metabolites in cells	MP and TP	TP	MP and TP
Ribonucleotide reductase inhibition	++++	++	++++
Inhibition DNA chain elongation	++++	++++	++
Inhibition RNA synthesis	+	++++	No
Mitochondrial release cytochrome c	++++	++	++++
Cellular elimination (CEM cells)	Slow	Not tested	Rapid

CEM, acute lymphocytic leukaemia cells; dCK, deoxycytidine kinase; MP, monophosphate; TP, triphosphate.

CARATTERISTICHE DEI DERIVATI DELLA DESOSSIADENOSINA

- Resistenza alla adenosina deaminasi
- Attività anche su cellule non proliferanti
 - inibizione della riparazione del DNA
 - alterazioni mitocondriali
 - attivazione diretta del programma apoptotico
- Mielosoppressione ed effetto immunosoppressivo

Drug	Main uses	Doses	Main adverse effects
Purine analogues			
Fludarabine	Chronic lymphocytic leukaemia	25 mg/m ² daily intravenously over 30 min for 5 days; repeat every 28 days	Myelosuppression, opportunistic infections, neurotoxicity
Cladribine	Hairy-cell leukaemia; non-Hodgkin lymphoma	4 mg/m ² daily by continuous intravenous infusion for 5 consecutive days	Myelosuppression, rash, septicaemia, fever
Pyrimidine analogues			
Cytarabine	Acute myelogenous and lymphoblastic leukaemias	Conventional dose — 100–200 mg/m ² intravenously on days 1 to 7 High-dose — 3 g/m ² intravenously over 1–3 h every 12 h for 12 doses	Conventional dose — myelosuppression, vomiting, stomatitis High dose — neurotoxicity, pericarditis
Gemcitabine	Pancreatic, lung, breast, and bladder cancers	1 g/m ² intravenously over 30 min once a week for 3 consecutive weeks every 4 weeks	Mild myelosuppression, nausea and vomiting, and skin rashes
Fluoropyrimidines			
Fluorouracil	Gastrointestinal, pancreatic, head and neck, renal, skin, prostate, and breast cancers	Mayo regimen — 450–600 mg/m ² intravenous bolus on days 1–5 every 4 weeks Roswell Park regimen — 450–600 mg/m ² intravenous bolus weekly Infusion — 200–400 mg/m ² daily continuously	Bolus — myelosuppression, stomatitis, nausea and vomiting, diarrhoea, angor pectoris Infusion — hand foot syndrome
Capecitabine	Relapsed breast and colorectal cancers	2.5 g/m ² daily by mouth; 2 weeks on drug, 1 week of rest	Hand-foot syndrome, diarrhoea, nausea and vomiting

High-dose administration
• *ara-C*

Degradation inhibitors
• *Eniluracil*

How can we increase nucleoside analogue cytotoxicity?

Degradation insensitive compounds
• *Eniluracil*
• *Cladribine*
• *Troxacitabine*

DNA repair inhibition
• *Fludarabine/anthracyclines*
• *ara-C/mitoxatrone*
• *Gemcitabine/cisplatin*

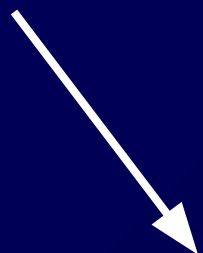
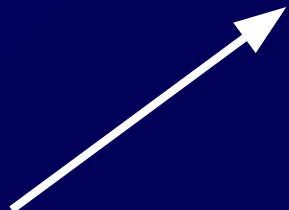
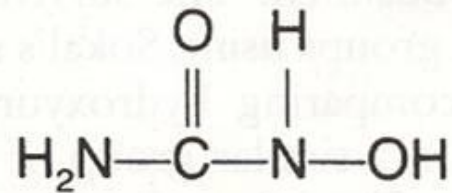

Figure 10-1. Structure of hydroxyurea.



MECCANISMI D'AZIONE DELLA IDROSSIUREA

- effetto scavenger sul radicale libero tirosinico presente nel sito attivo
- liberazione di NO

MECCANISMI DI RESISTENZA ALLA IDROSSIUREA

- ↑ DEI LIVELLI DI RIBONUCLEOTIDE REDUTTASI
- PRODUZIONE DI FORME ALTERATE DELL'ENZIMA

IMPIEGO DELLA IDROSSIUREA IN PATOLOGIE NON NEOPLASTICHE

- ANEMIA FALCIFORME
- INFEZIONE DA HIV
- TROMBOCITEMIA
- POLICITEMIA VERA

EFFETTI TOSSICI DEGLI ANALOGHI DELLA IDROSSIUREA

- MIELODEPRESSIONE
- EFFETTI GI E DERMATOLOGICI
- ↑ RISCHIO DI INSORGENZA DI LEUCEMIE SECONDARIE
- EFFETTO TERATOGENO

