

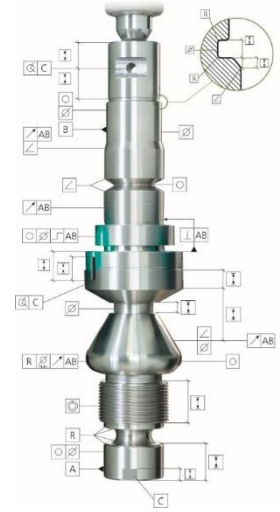

OPTICLINE

OPTICLINE

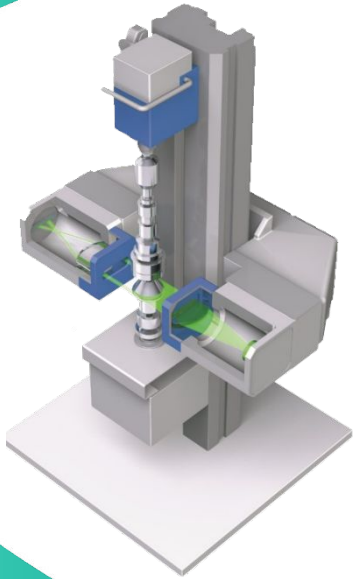

ПРИНЦИП РАБОТЫ

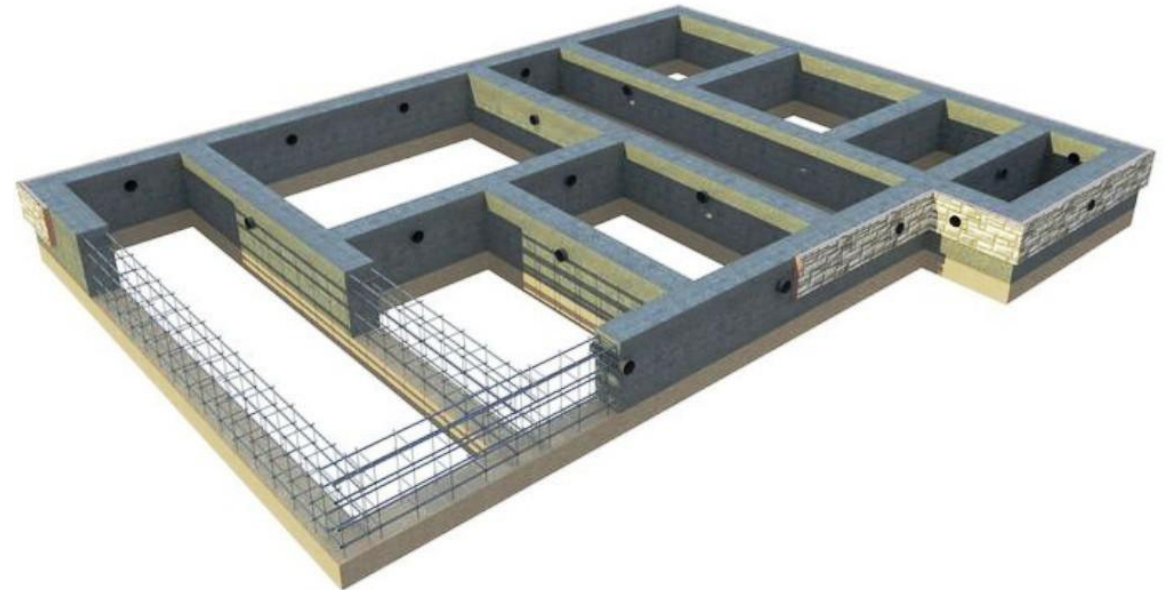

- Размеры
- Параметры резьбы
- Отклонение формы
- Параметры расположения поверхностей
- Специальные параметры

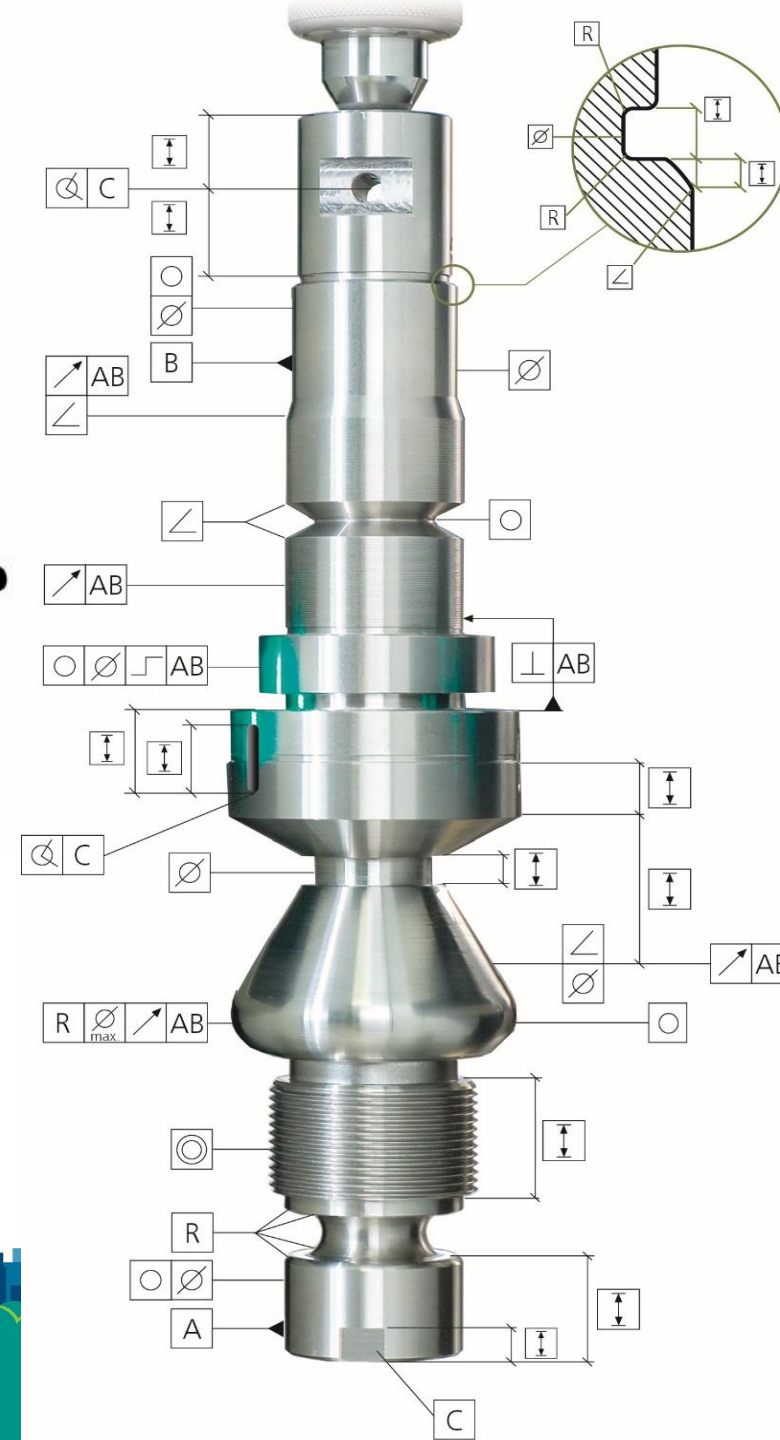

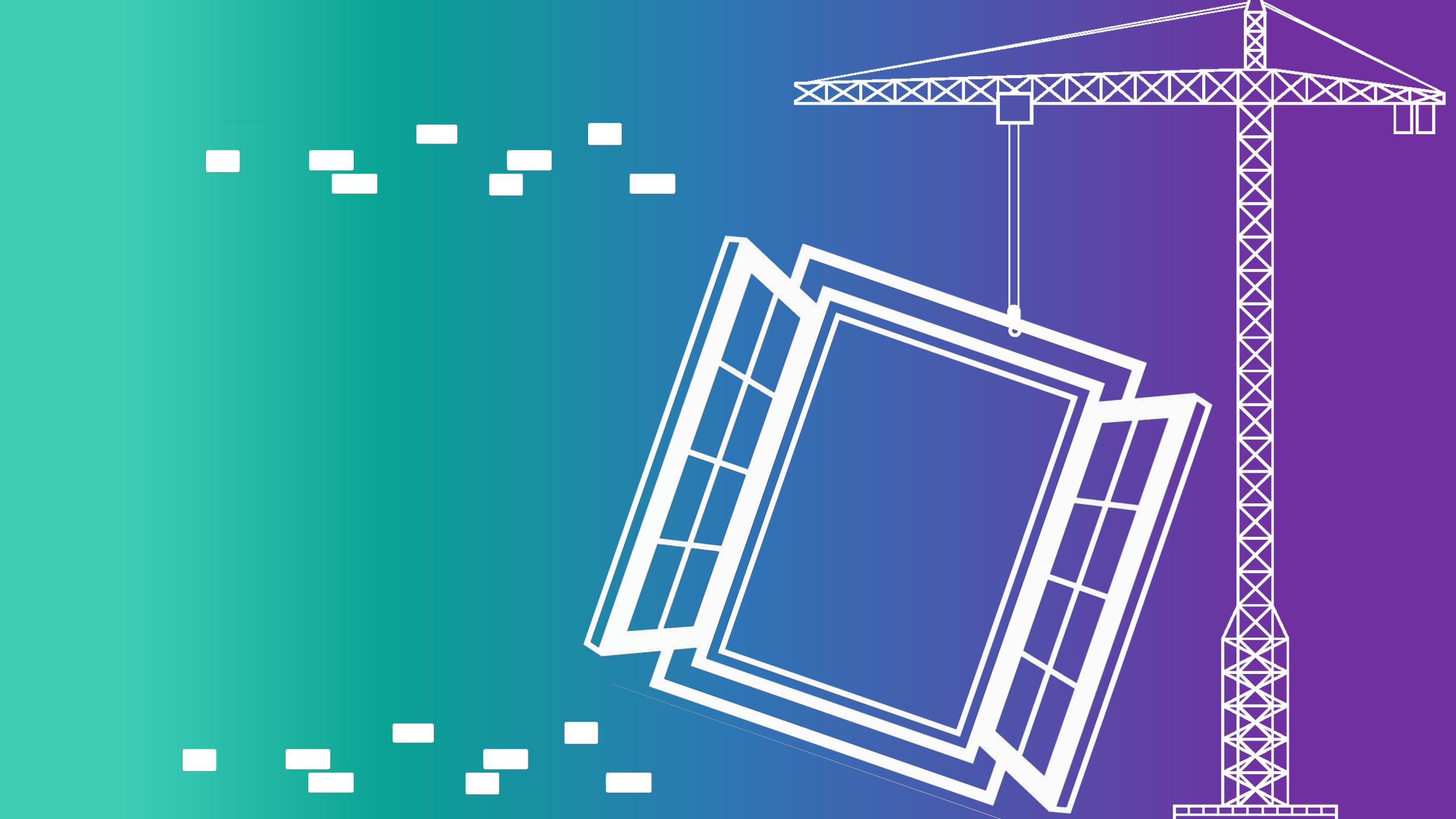



OPTICLI
NE
CS



OPTICLI
NE
C



OPTICLI
NE
CA

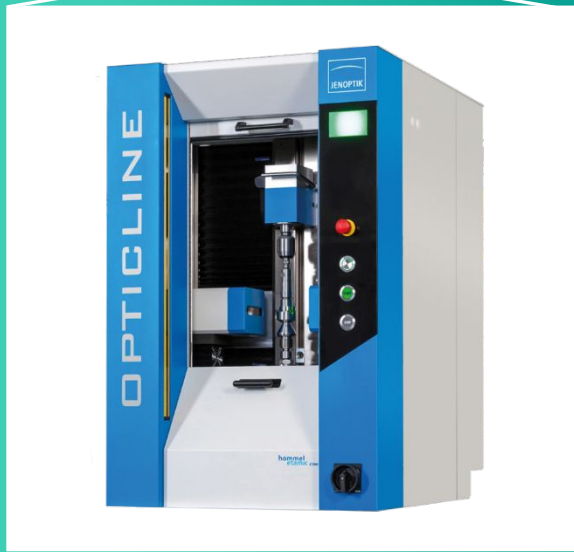

OPTICLI
NE
C



$(2.6+L[\text{mm}]/200)$ MKM
 $(1.0+D[\text{mm}]/200)$

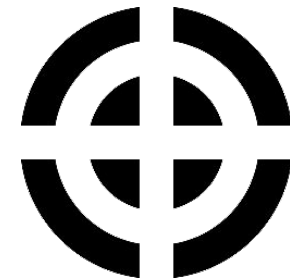

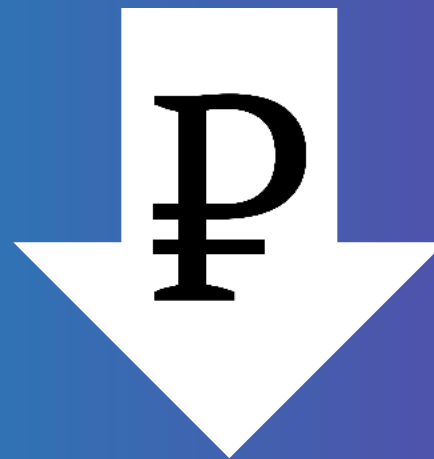

30%

$(5.0 + L[\text{mm}] / 100)$ MKM
 $(2.0 + D[\text{mm}] / 100)$ MKM

OPTICLI
NE
CS

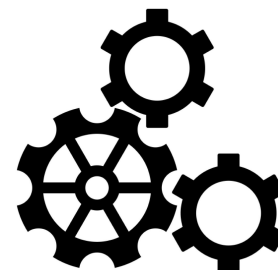



OPTICLI
NE
CA



$(2.6+L[\text{mm}]/200)$ MKM
 $(1.0+D[\text{mm}]/200)$

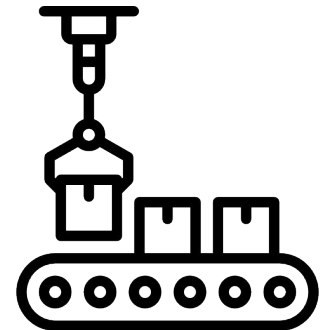
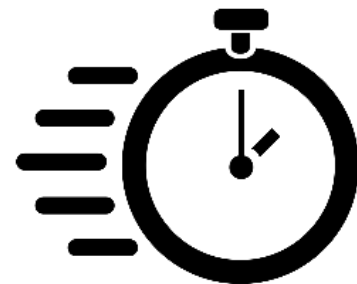

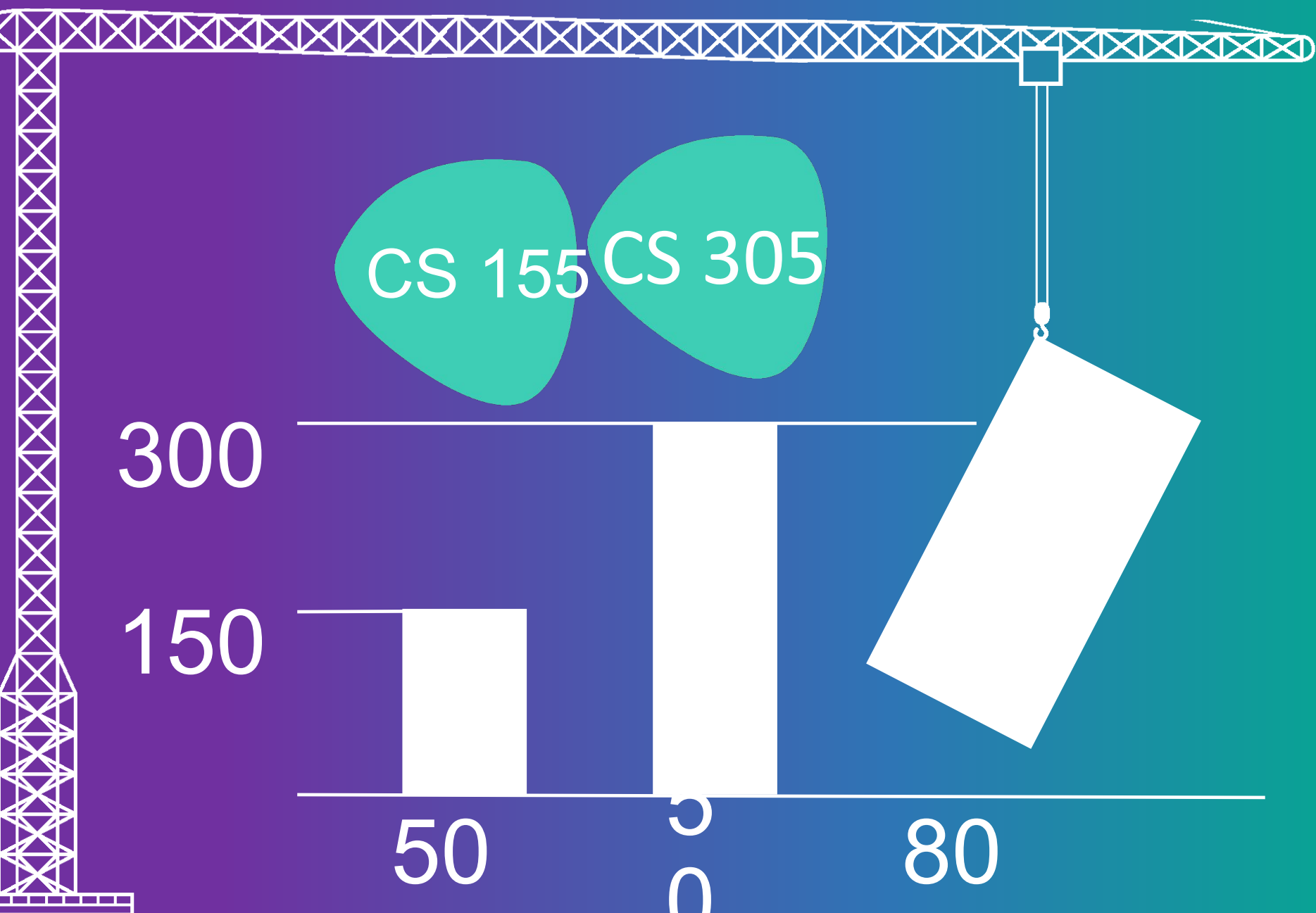

CS 308

CS 155 CS 305



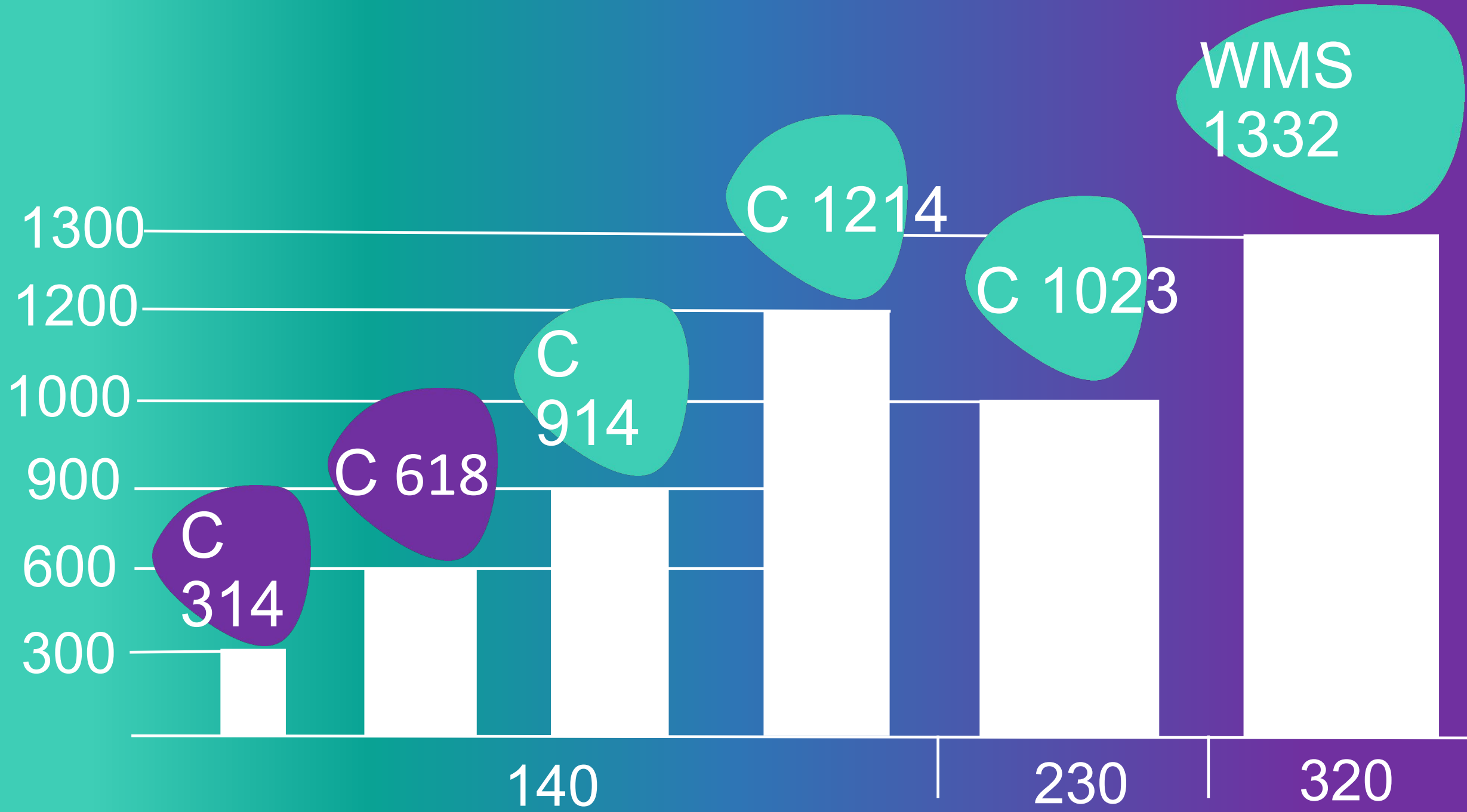

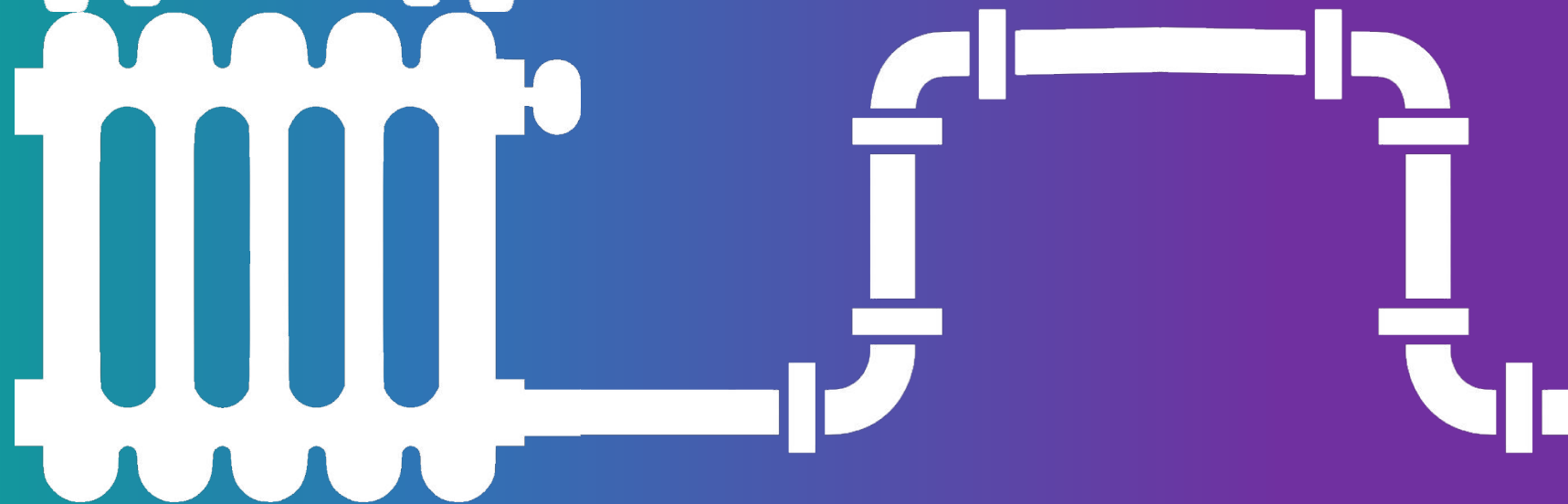



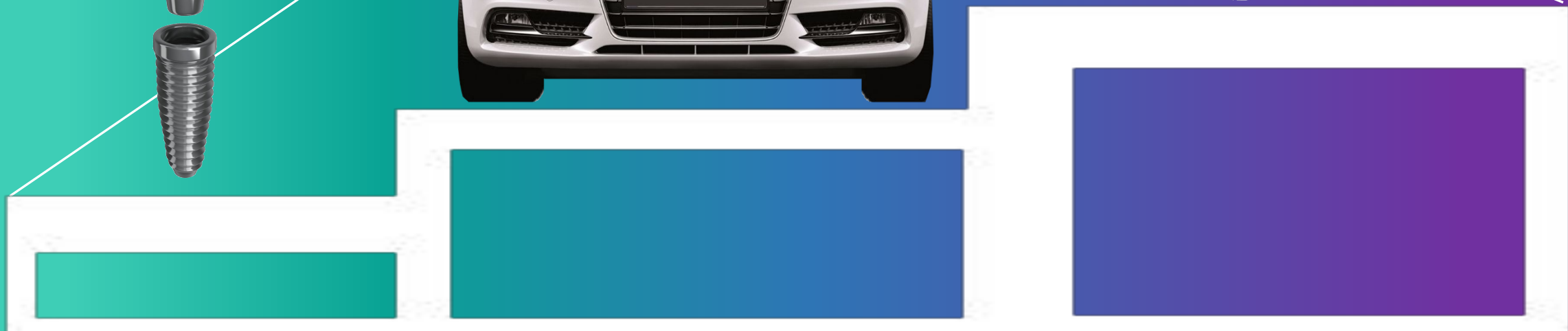

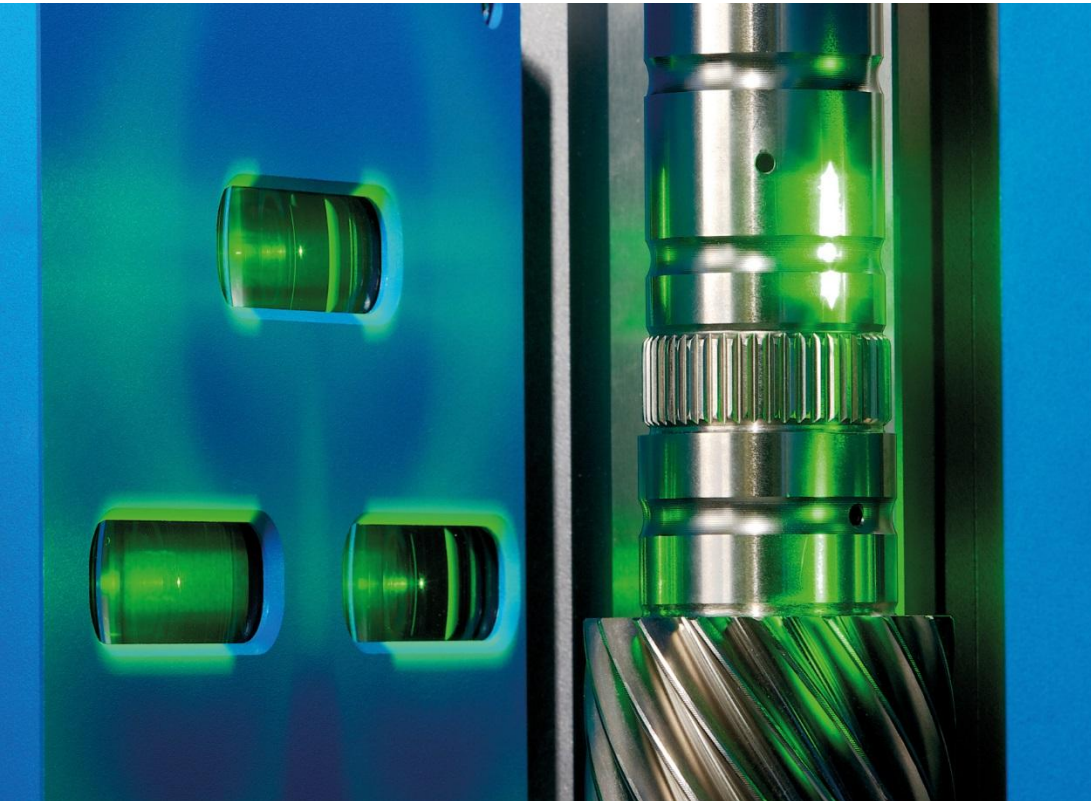

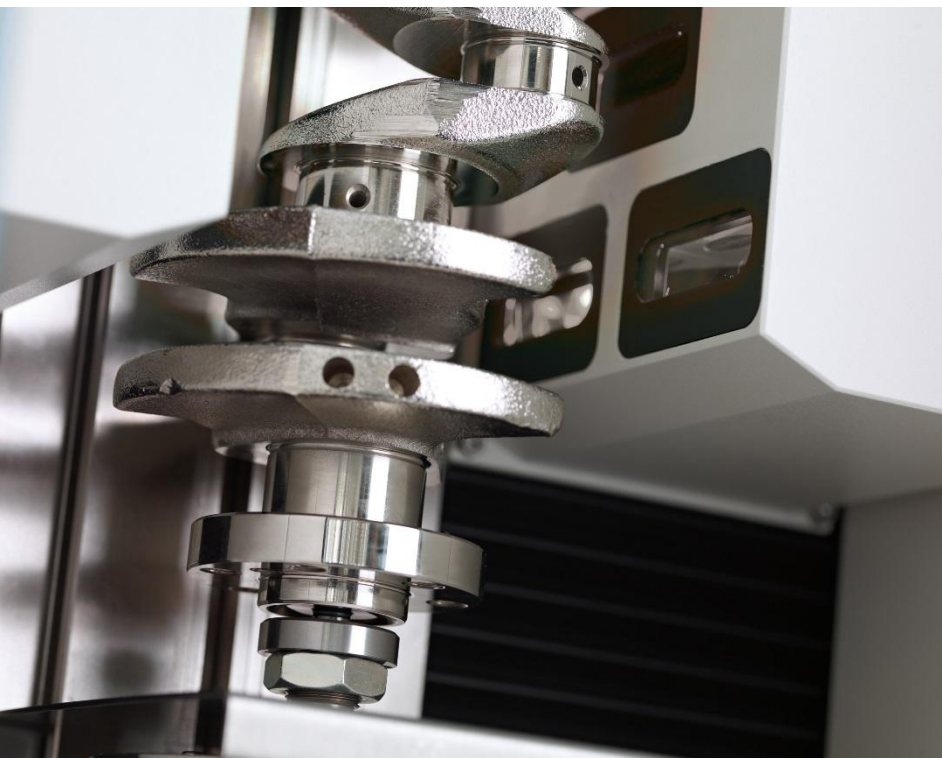
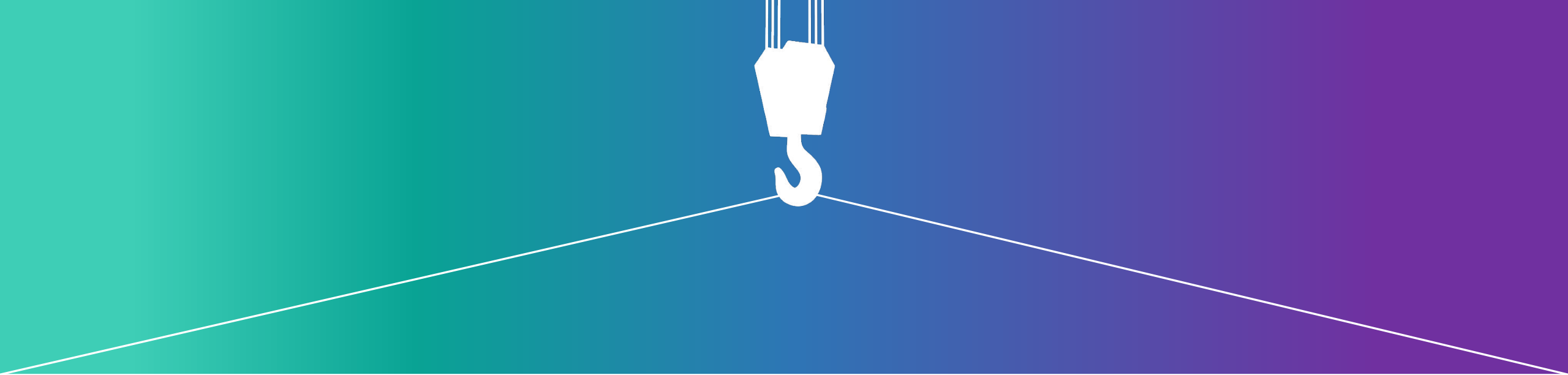

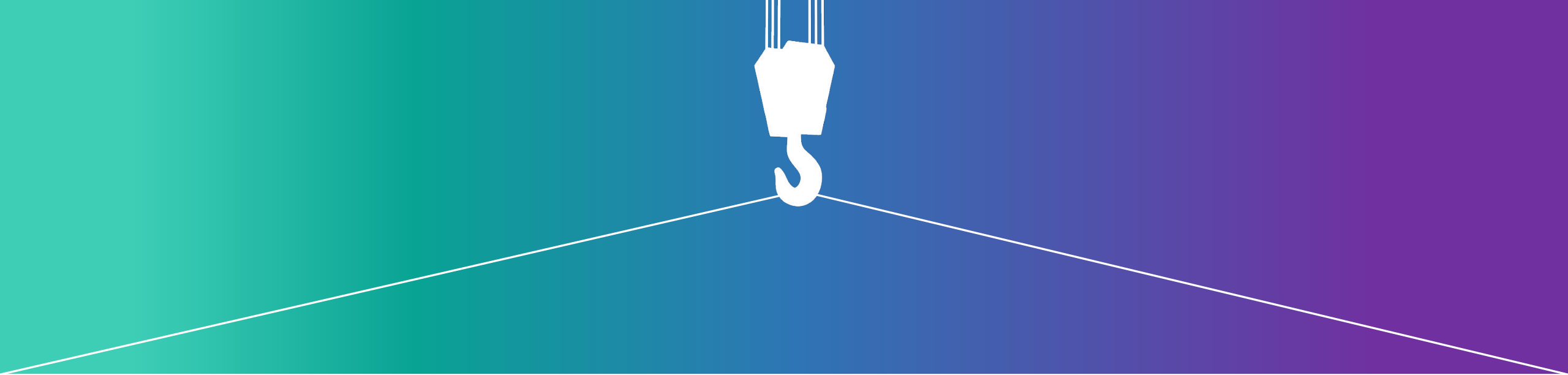



JENOPTIK

