



ГЕММОЛОГИЧЕСКАЯ
АКАДЕМИЯ

Ювелирный эскиз

Диана Табачкова
Москва 2021



- ◆ Художник и дизайнер ювелирных украшений
- ◆ Член Международной Ассоциации «Союз дизайнеров» и Творческого Союза художников России
- ◆ Высшее образование дизайнера-ювелира в Central Saint Martin College of Art & Design в Лондоне и Высшей школы ювелирного дизайна «Школы Шароновых» (ТГУ)
- ◆ Ученое звание - доцент
- ◆ Педагогический стаж 17 лет
- ◆ Преподаватель проектирования ювелирных изделий и пластического моделирования
- ◆ Куратор международных биеннале авторских изделий из янтаря «Алатырь»
- ◆ Тренер национальной сборной компетенции Ювелирное дело «WorldSkills Russia»
- ◆ Кавалер Ордена Михаила Перхина за высшие творческие достижения, пропаганду искусства Фаберже и воспитание молодых ювелиров
- ◆ Лауреат более 10и международных и российских конкурсов ювелирного дизайна

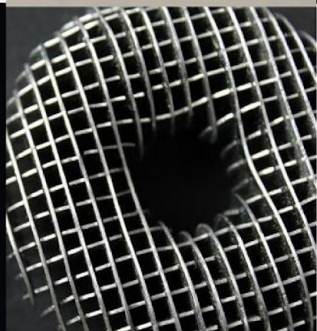
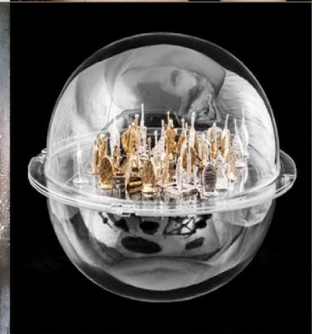
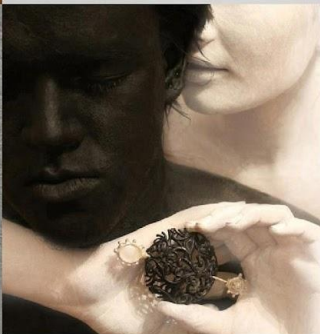
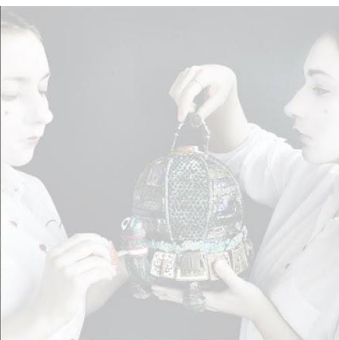

ШКОЛА ШАРОНОВЫХ
ЮВЕЛИРНЫЙ ДИЗАЙН
ХУДОЖЕСТВЕННЫЙ
М Е Т А Л Л

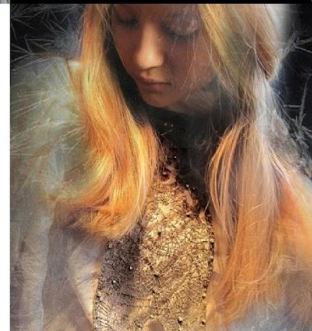

ул Смирновская 25 ст 10
М О С К В А
 sharonows@yandex.ru







ГЕММОЛОГИЧЕСКАЯ
АКАДЕМИЯ

Введение





ГЕММОЛОГИЧЕСКАЯ
АКАДЕМИЯ





ГЕММОЛОГИЧЕСКАЯ
АКАДЕМИЯ





ГЕММОЛОГИЧЕСКАЯ
АКАДЕМИЯ

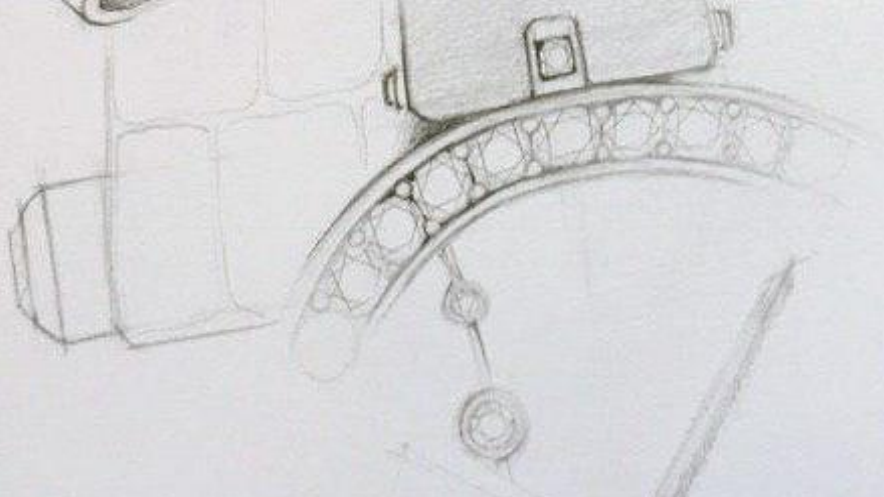
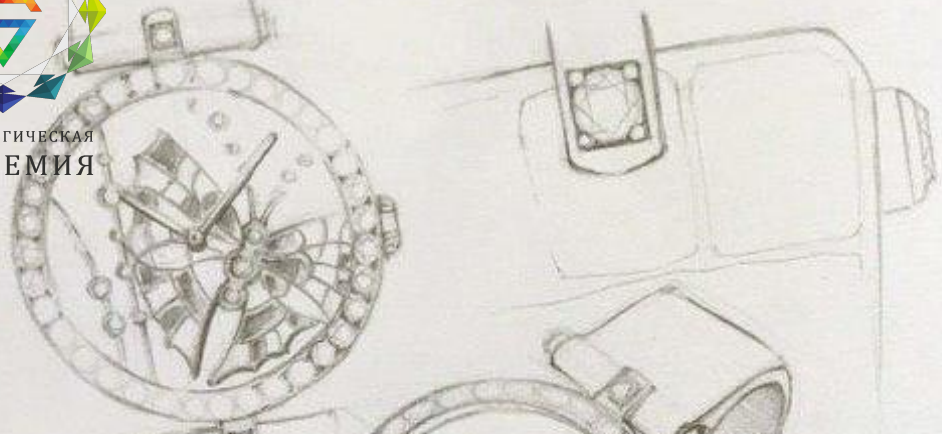



ГЕММОЛОГИЧЕСКАЯ
АКАДЕМИЯ

Какими навыками должен обладать дизайнер ювелирных украшений

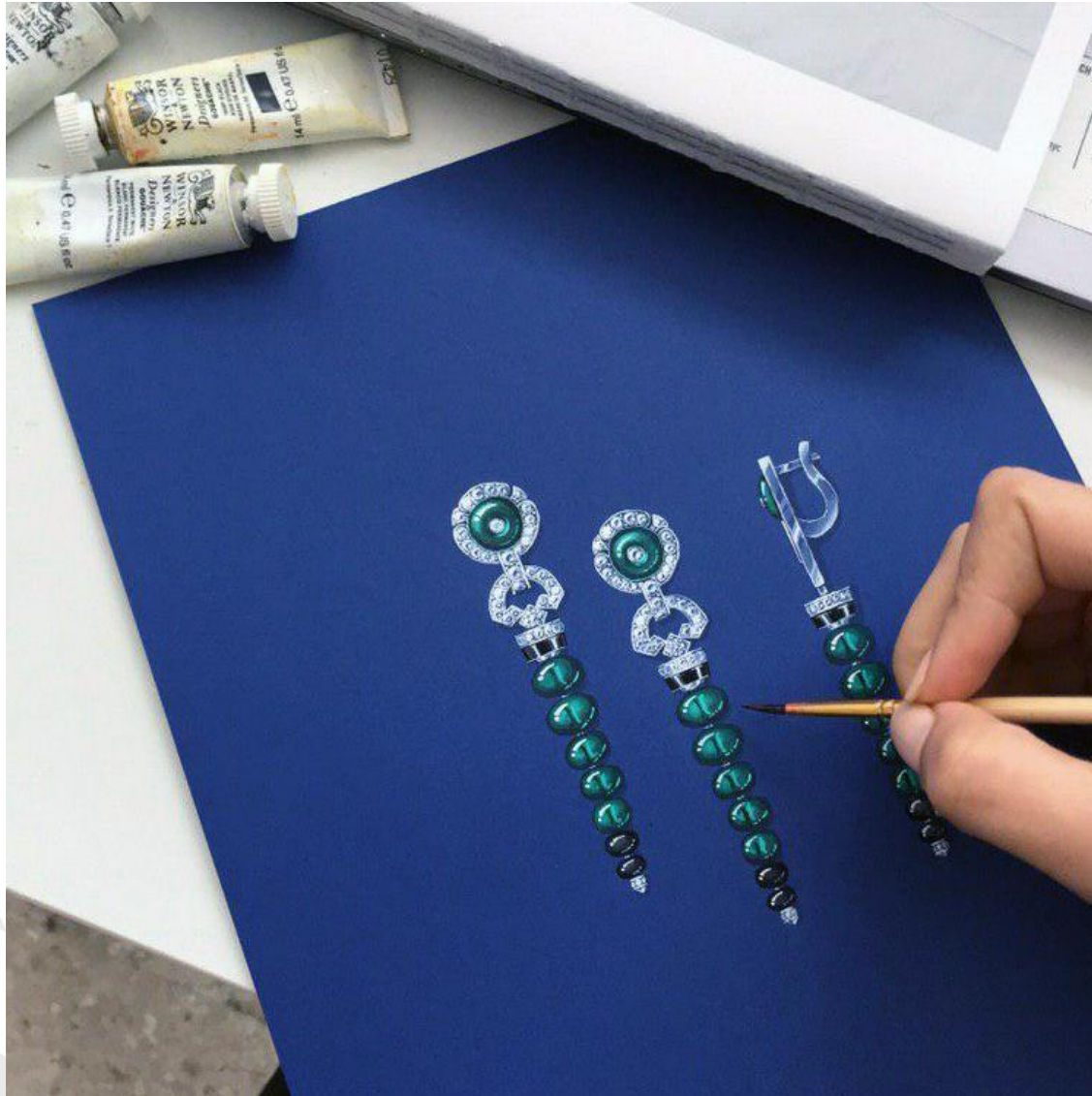



ГЕММОЛОГИЧЕСКАЯ
АКАДЕМИЯ

- -умение рисовать
- -умение творчески мыслить
- -умение мыслить быстро
- -владение графическими программами (Photoshop, Illustrator, Rhinoceros...)
- -понимание технологических процессов изготовления ювелирных украшений
- -базовое знание минералогии и геммологии
- -знание основ композиции
- -навык анализа рынка, его тенденций



ГЕММОЛОГИЧЕСКАЯ
АКАДЕМИЯ

Требование к ювелирному эскизу

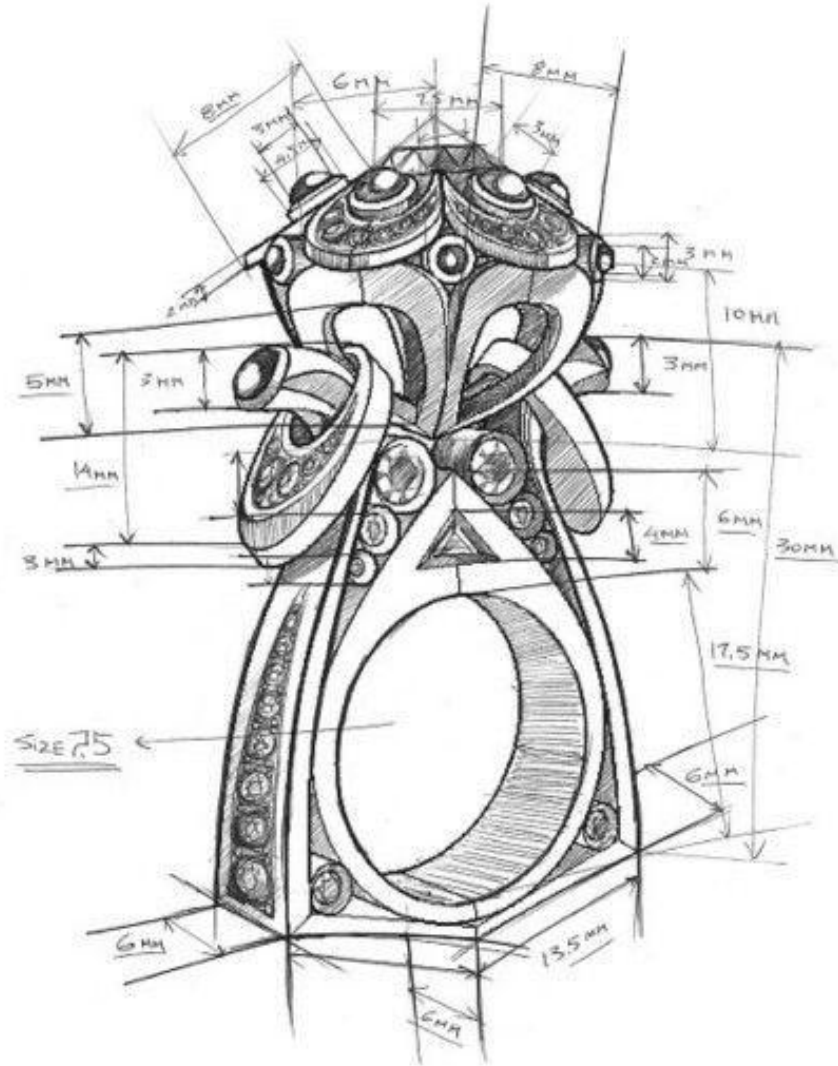

Роль дизайнера



ГЕММОЛОГИЧЕСКАЯ
АКАДЕМИЯ

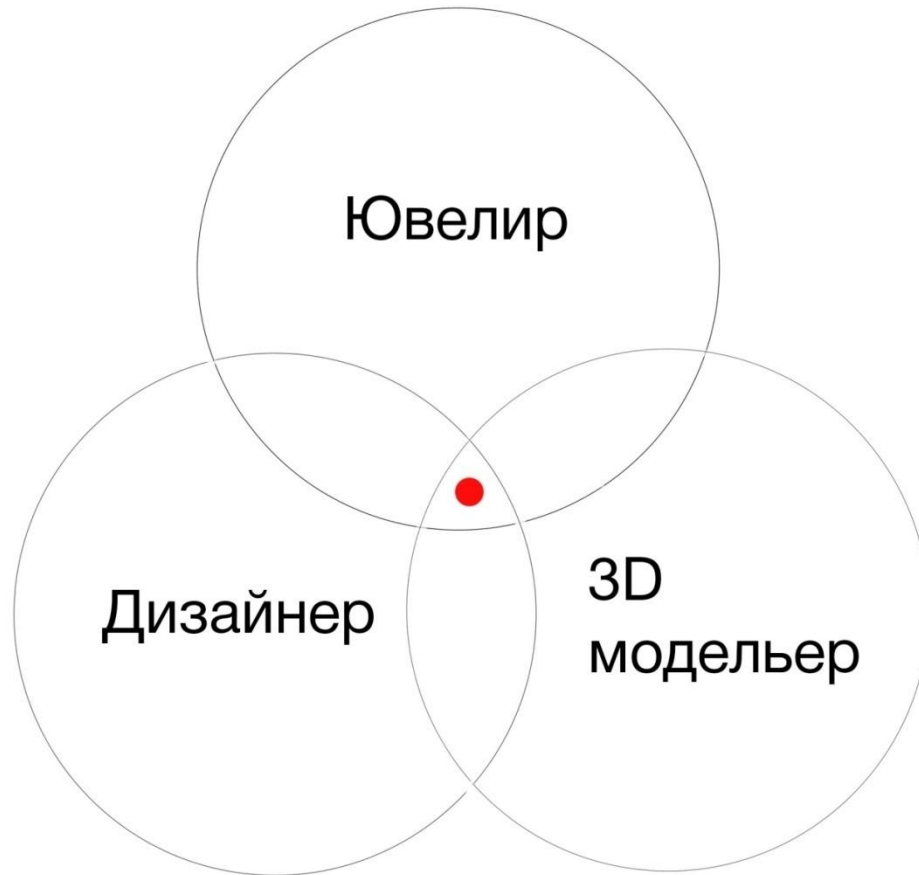



ГЕММОЛОГИЧЕСКАЯ
АКАДЕМИЯ

Mood Board









ГЕМОЛОГИЧЕСКАЯ
АКАДЕМИЯ



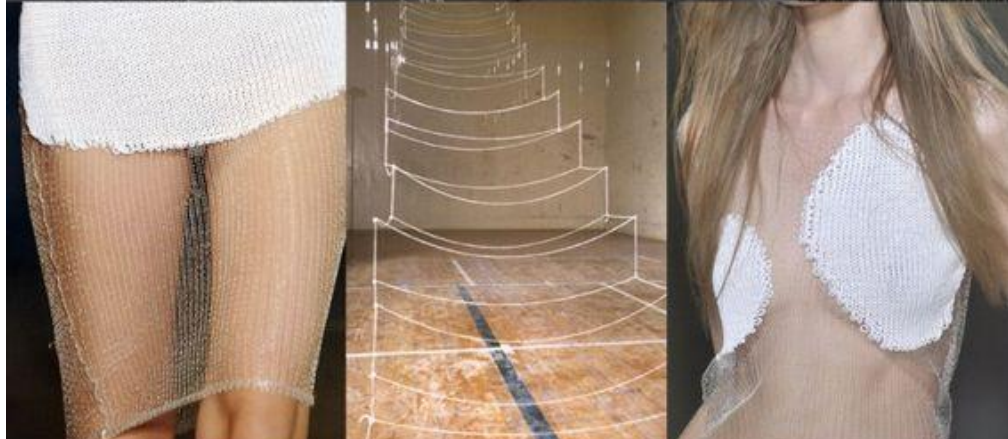
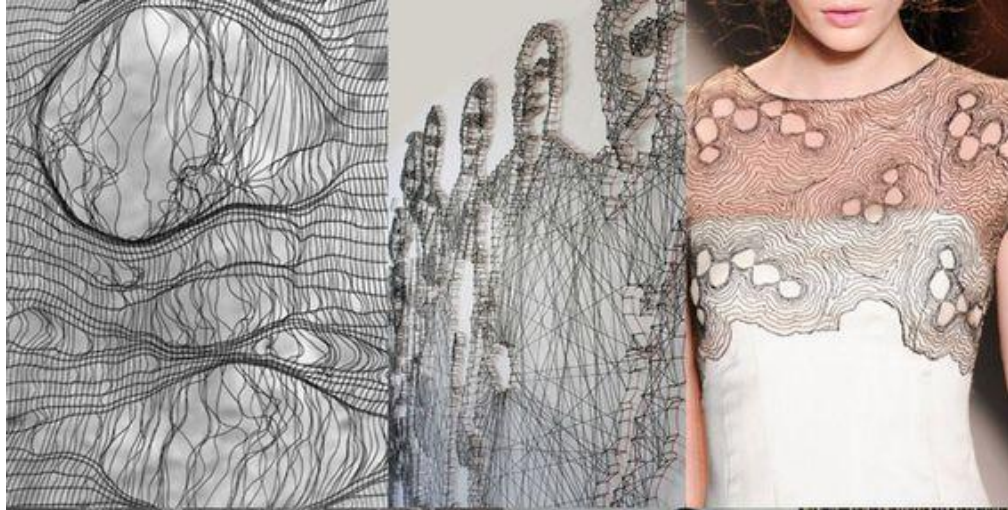









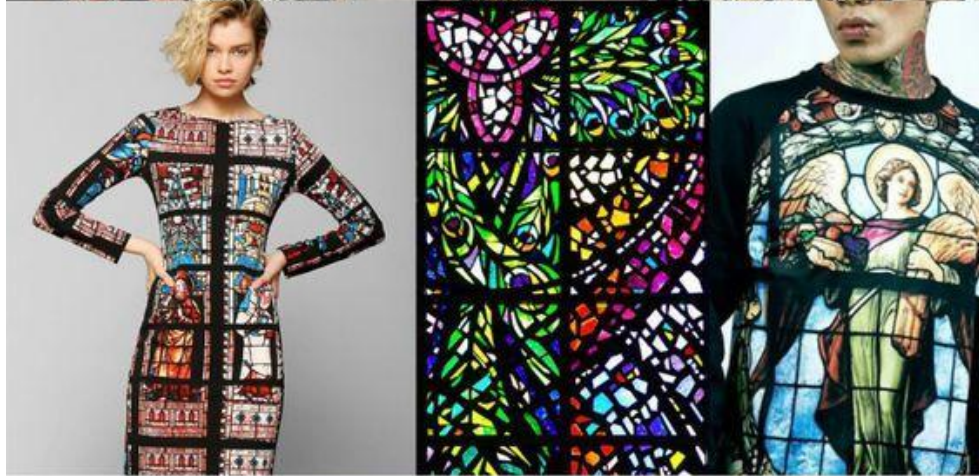



ГЕММОЛОГИЧЕСКАЯ
АКАДЕМИЯ

This was Paris!

Here are a few
of my favourite
shows



Rick Owens



Chanel



Louis Vuitton

At Dior &
Dior...



Gold thread
alot!



Zoran



Ane



The V.I.S (very important
shoe)
The new Céline
sneakers.

Metro parisien
forever.



I sort of wanted to buy
at how beautiful was



Valentino

My one and
only croissant of
all Paris-FW.
I stuck to my
healthy routines!

My accessory of
choice? That Dior
earrings.

Couldn't stop
the Instagramming
the Eiffel Tower!



Each season, you can find
these cool Men Men seating
cards on your seats.



I decided to collect them,
even though I have no idea
what I'd do with them!



ГЕММОЛОГИЧЕСКАЯ
АКАДЕМИЯ





ГЕМОЛОГИЧЕСКАЯ
АКАДЕМИЯ



BOX TREE
(Wong wood)

BONES

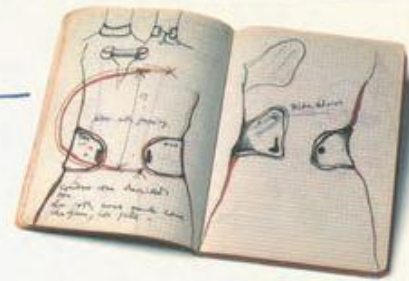

HAYASHI 71
brass bones
(dishes)



Thick bar - candlestick

- because they are just the same
- because of their shape
- Or just this!



my own bone



RABBIT BONE
steady bar -
crown holder -

Head of wild animal,
found in
a Thrift
shop in
New York.







ГЕММОЛОГИЧЕСКАЯ
АКАДЕМИЯ

Графические средства

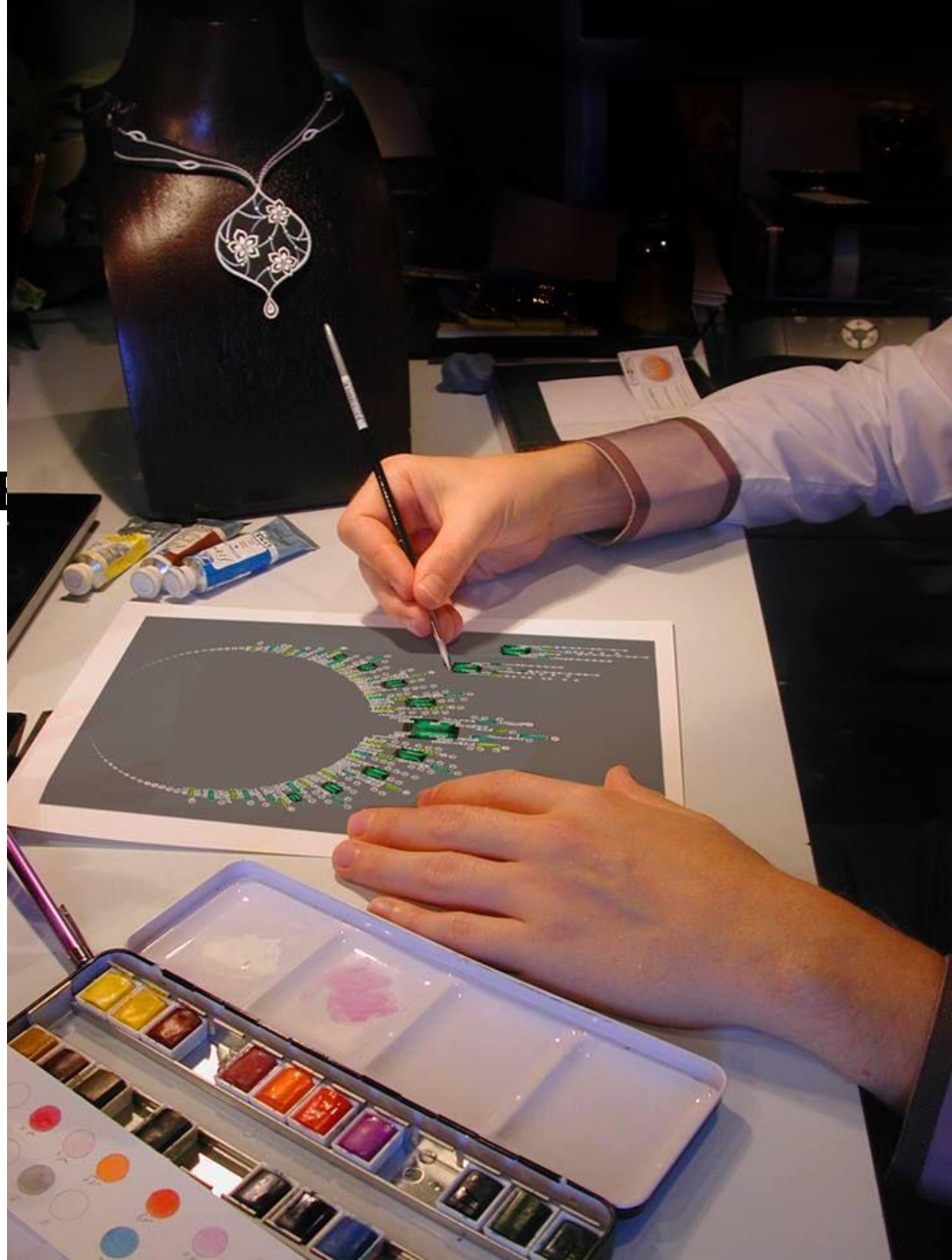



ГЕММОЛОГИЧЕСКАЯ
АКАДЕМИЯ

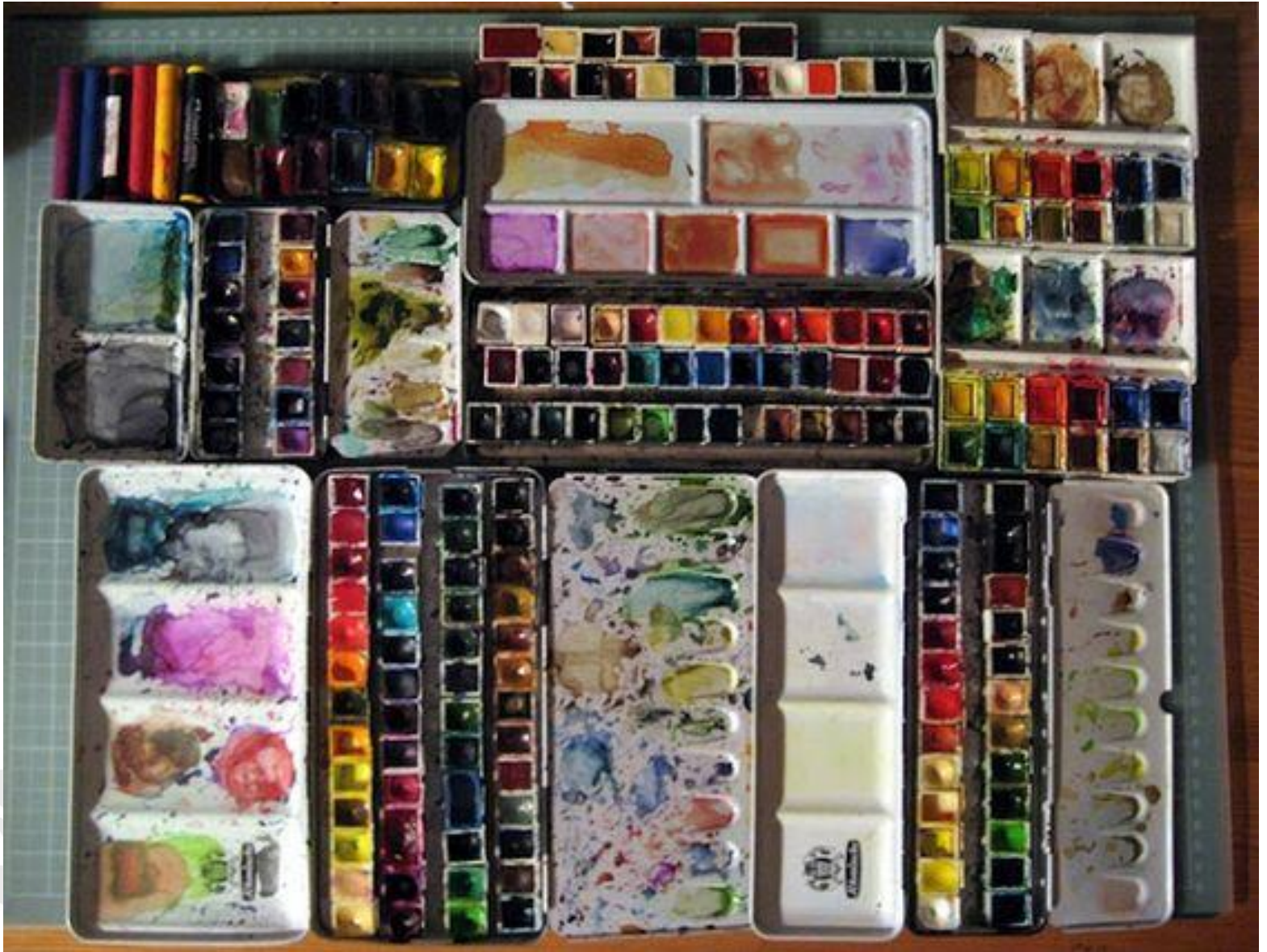



ГЕМОЛОГИЧЕСКАЯ
АКАДЕМИЯ





ГЕММОЛОГИЧЕСКАЯ
АКАДЕМИЯ





ГЕММОЛОГИЧЕСКАЯ
АКАДЕМИЯ





ГЕММОЛОГИЧЕСКАЯ
АКАДЕМИЯ





ГЕМОЛОГИЧЕСКАЯ
АКАДЕМИЯ





ГЕММОЛОГИЧЕСКАЯ
АКАДЕМИЯ





ГЕМОЛОГИЧЕСКАЯ
АКАДЕМИЯ

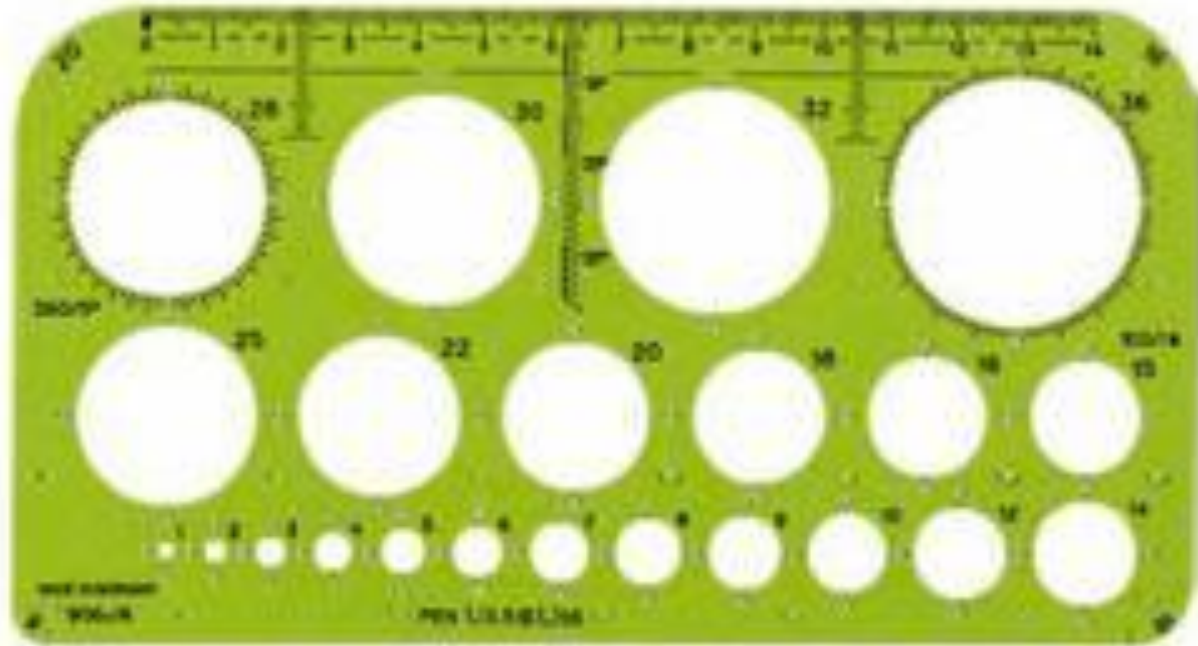



ГЕММОЛОГИЧЕСКАЯ
АКАДЕМИЯ





ГЕММОЛОГИЧЕСКАЯ
АКАДЕМИЯ

Подход к эскизам в ювелирных домах





ГЕММОЛОГИЧЕСКАЯ
АКАДЕМИЯ

BVLGARI





ГЕММОЛОГИЧЕСКАЯ
АКАДЕМИЯ





ГЕММОЛОГИЧЕСКАЯ
АКАДЕМИЯ





ГЕММОЛОГИЧЕСКАЯ
АКАДЕМИЯ





ГЕММОЛОГИЧЕСКАЯ
АКАДЕМИЯ





ГЕММОЛОГИЧЕСКАЯ
АКАДЕМИЯ





ГЕММОЛОГИЧЕСКАЯ
АКАДЕМИЯ





ГЕММОЛОГИЧЕСКАЯ
АКАДЕМИЯ

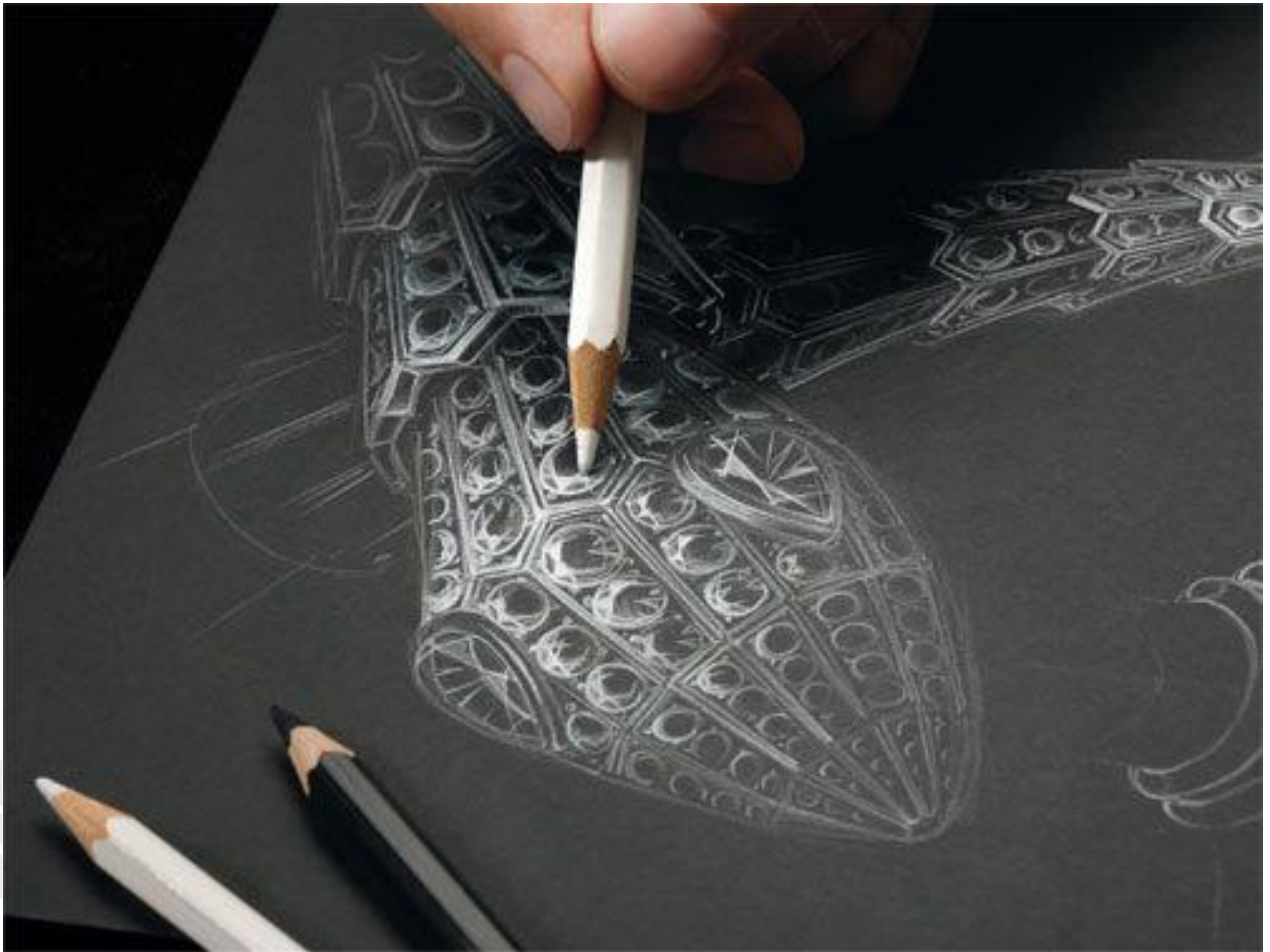



ГЕММОЛОГИЧЕСКАЯ
АКАДЕМИЯ

Chopard
GENÈVE





ГЕММОЛОГИЧЕСКАЯ
АКАДЕМИЯ

Chopard
GENÈVE





ГЕММОЛОГИЧЕСКАЯ
АКАДЕМИЯ





ГЕММОЛОГИЧЕСКАЯ
АКАДЕМИЯ

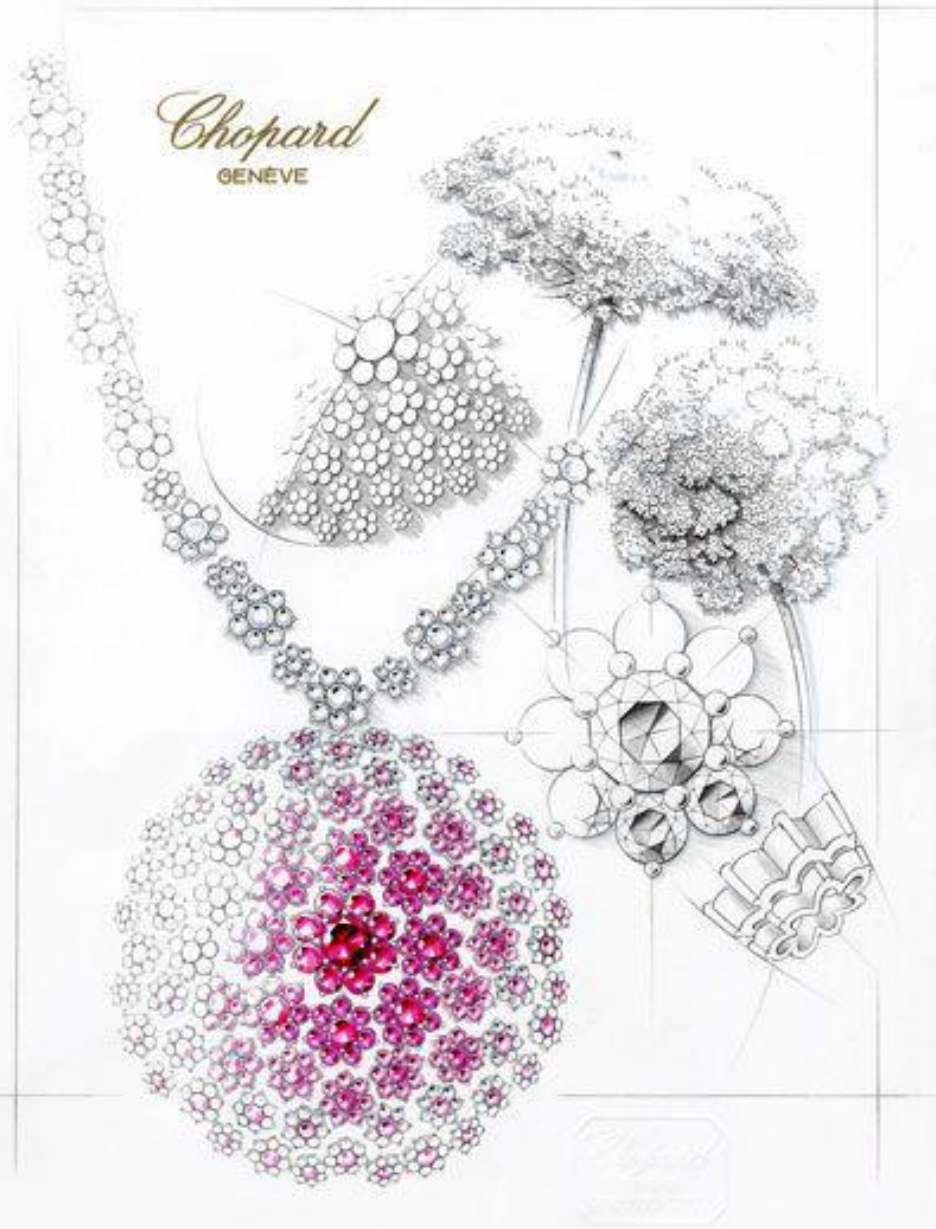



ГЕММОЛОГИЧЕСКАЯ
АКАДЕМИЯ





ГЕММОЛОГИЧЕСКАЯ
АКАДЕМИЯ





ГЕММОЛОГИЧЕСКАЯ
АКАДЕМИЯ

Chopard
GENÈVE



— DRESS
— 18K 750/1000 —

— 18K 750/1000
— 18K 750/1000 —





ГЕММОЛОГИЧЕСКАЯ
АКАДЕМИЯ



Chopard



ГЕММОЛОГИЧЕСКАЯ
АКАДЕМИЯ

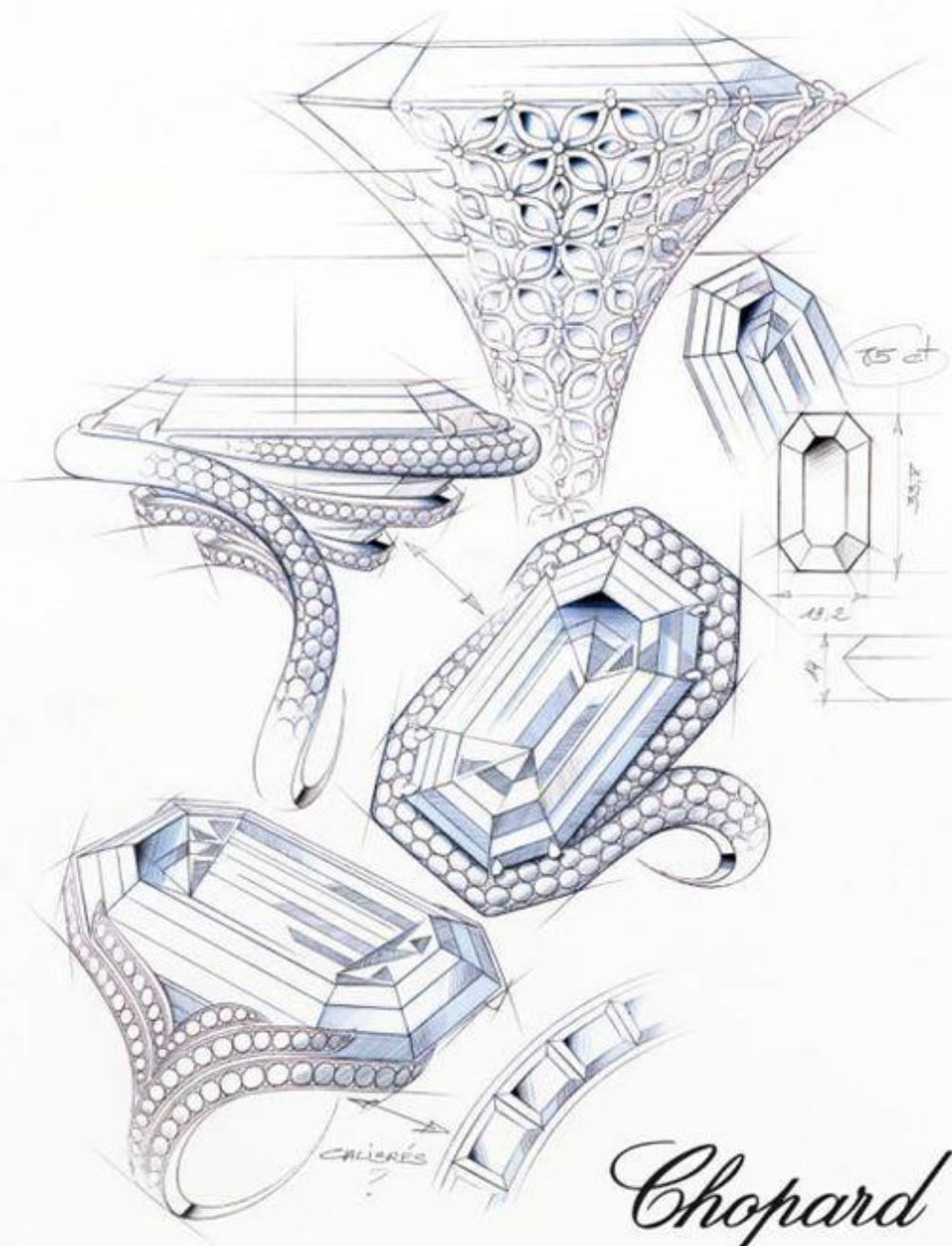

Chopard



ГЕММОЛОГИЧЕСКАЯ
АКАДЕМИЯ

Chopard
GENÈVE

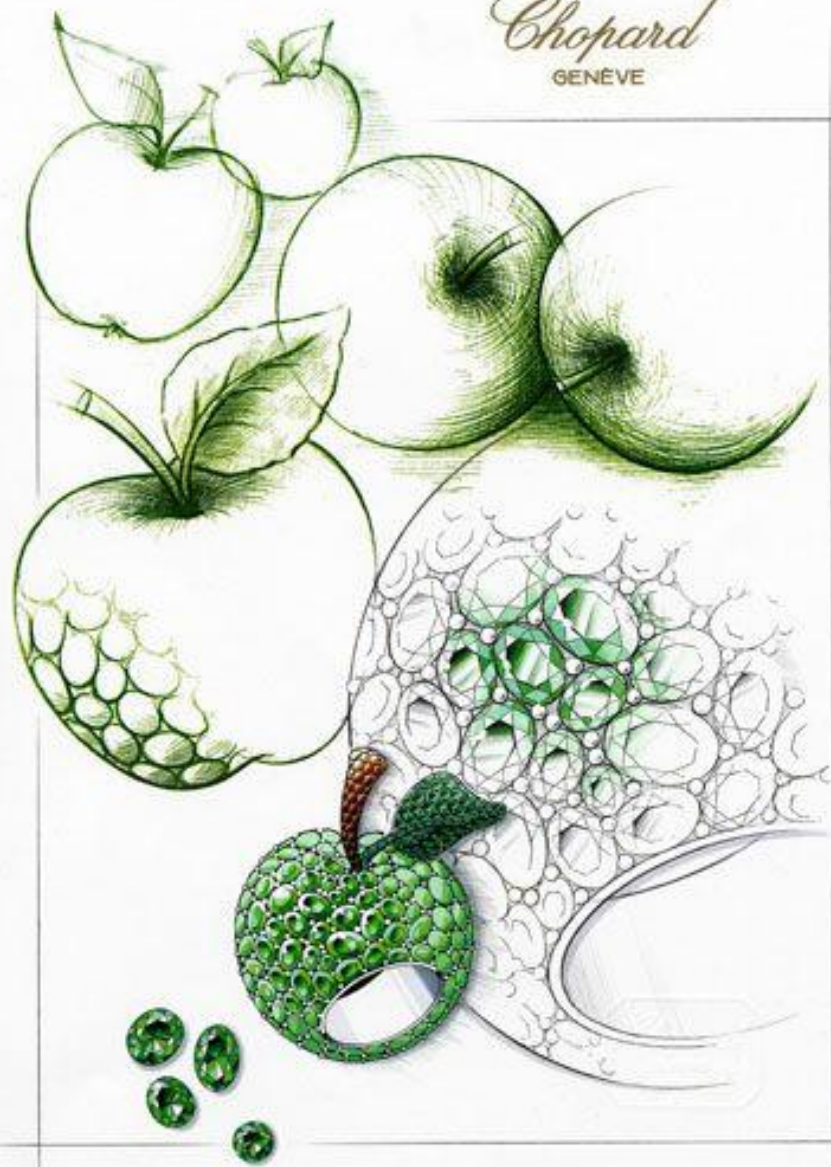



ГЕММОЛОГИЧЕСКАЯ
АКАДЕМИЯ

Dior





ГЕММОЛОГИЧЕСКАЯ
АКАДЕМИЯ





ГЕММОЛОГИЧЕСКАЯ
АКАДЕМИЯ





ГЕМОЛОГИЧЕСКАЯ
АКАДЕМИЯ



Christian Dior
COUTURE
PROPRIÉTÉ EXCLUSIVE
DOCUMENT CONFIDENTIEL
DIVULGATION STRICTEMENT INTERDITE

Victoire de Castellane



ГЕММОЛОГИЧЕСКАЯ
АКАДЕМИЯ



Christian Dior
COUTURE
PROPRIETE EXCLUSIVE
DOCUMENT CONFIDENTIEL
DIVULGATION STRICTEMENT INTERDITE

Vicoire de Castellane



ГЕМОЛОГИЧЕСКАЯ
АКАДЕМИЯ





ГЕММОЛОГИЧЕСКАЯ
АКАДЕМИЯ



Christian Dior
COUTURE
PROPRETE EXCLUSIVE
DOCUMENT CONFIDENTIEL
DIVULGATION STRICTEMENT INTERDITE

Vicoire de Castellane



ГЕММОЛОГИЧЕСКАЯ
АКАДЕМИЯ





ГЕММОЛОГИЧЕСКАЯ
АКАДЕМИЯ





ГЕММОЛОГИЧЕСКАЯ
АКАДЕМИЯ

TIFFANY & Co.





ГЕМОЛОГИЧЕСКА
АКАДЕМИ

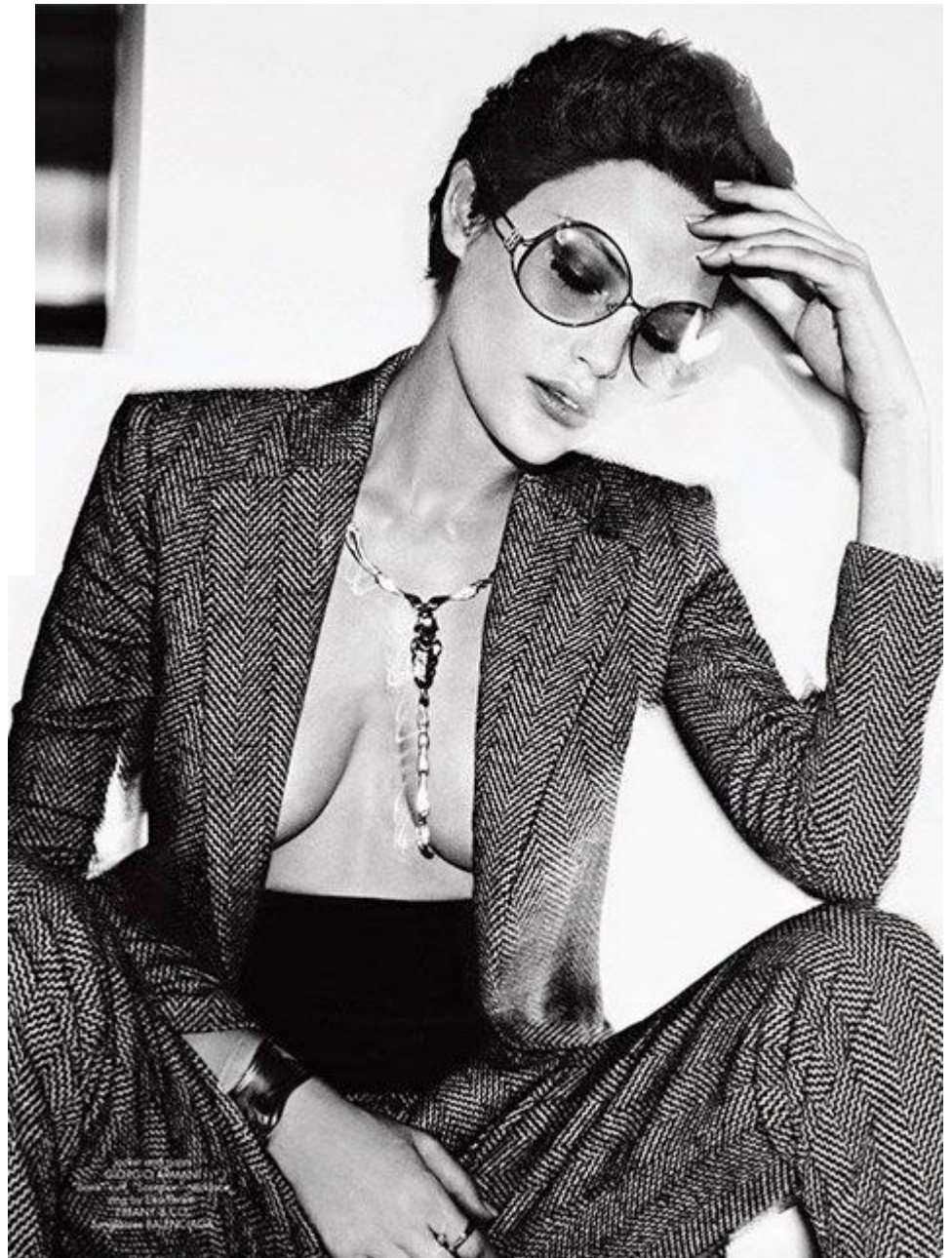
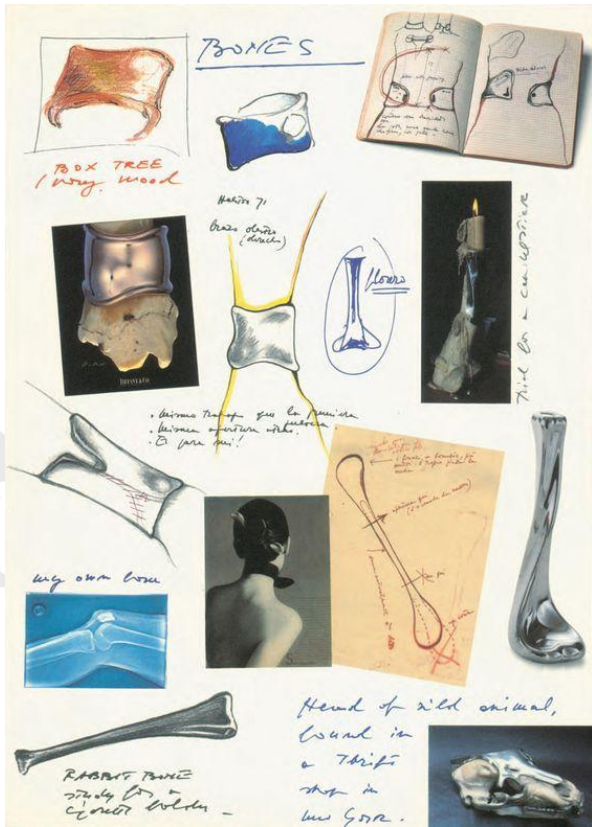



ГЕММОЛОГИЧЕСКАЯ
АКАДЕМИЯ





ГЕММОЛОГИЧЕСКАЯ
АКАДЕМИЯ





ГЕММОЛОГИЧЕСКАЯ
АКАДЕМИЯ



© Tiffany & Co. / Paloma Picasso. Design 1.011



ГЕМОЛОГИЧЕСКАЯ
АКАДЕМИЯ



HOTEL DES BERGUES
GENEVE

STYLED GEM CUTS

reduced
in size

half done



SNAKE CHAIN

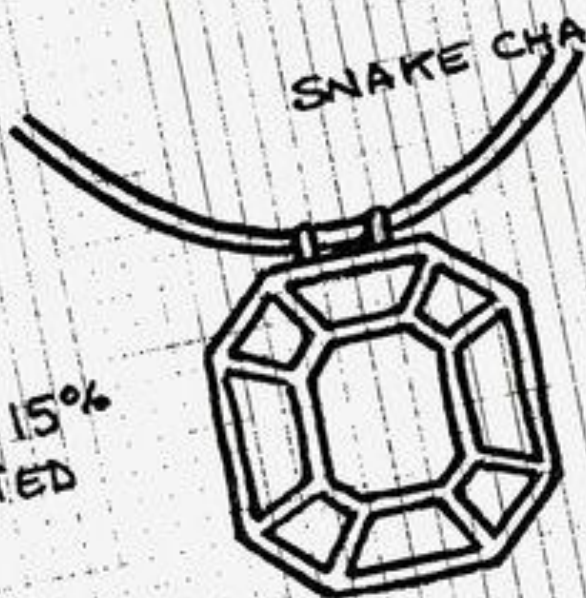

only metal
samples
both
ways

- SHOULD BE DONE 15% SMALLER, TO BE TRIED FLAT OR 3 D.

- CAN BE DONE IN 18K GOLD OR PAVE DIAMOND

EMERALD CUT



ГЕММОЛОГИЧЕСКАЯ
АКАДЕМИЯ



olive leaf



Paloma Picasso



ГЕММОЛОГИЧЕСКАЯ
АКАДЕМИЯ





ГЕМОЛОГИЧЕСКАЯ
АКАДЕМИЯ

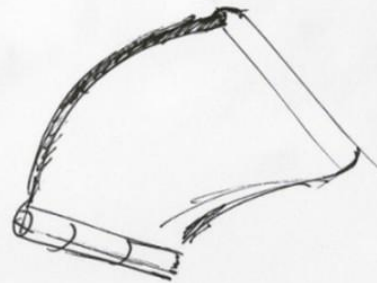
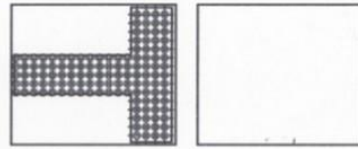
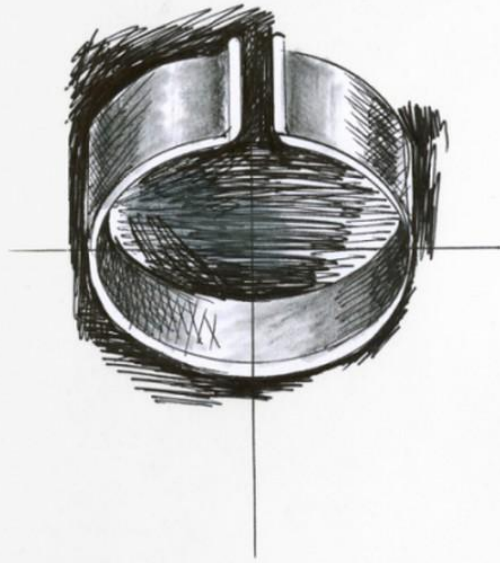



ГЕММОЛОГИЧЕСКАЯ
АКАДЕМИЯ

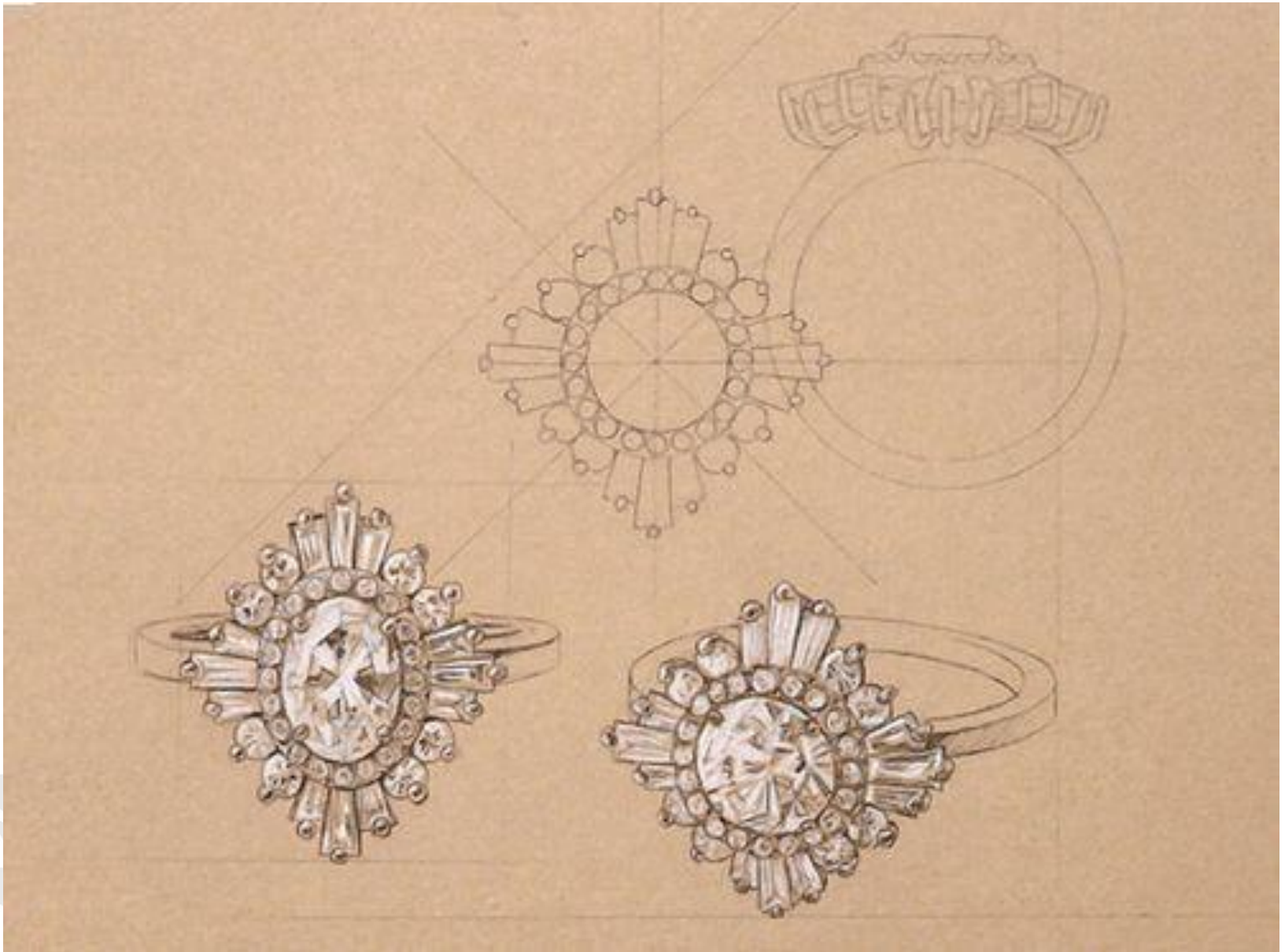



ГЕММОЛОГИЧЕСКАЯ
АКАДЕМИЯ





ГЕММОЛОГИЧЕСКАЯ
АКАДЕМИЯ

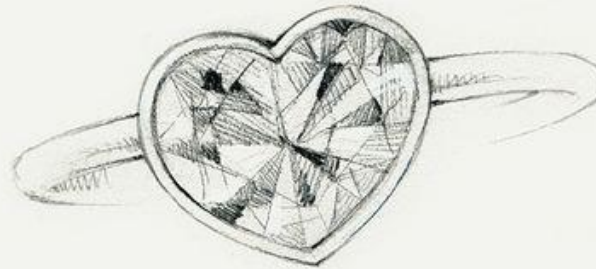
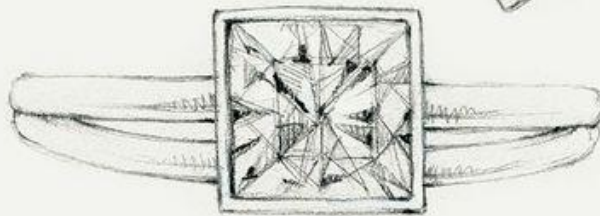
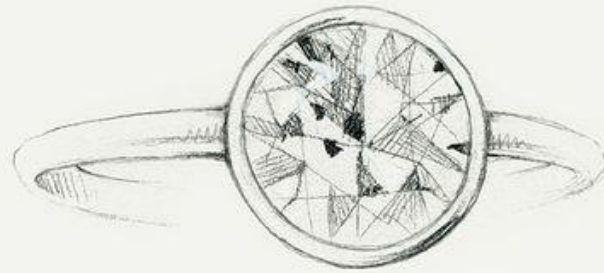



ГЕММОЛОГИЧЕСКАЯ
АКАДЕМИЯ

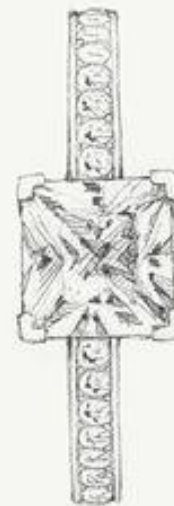
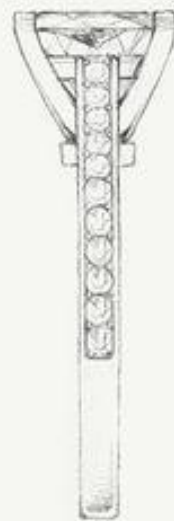



ГЕММОЛОГИЧЕСКАЯ
АКАДЕМИЯ

Van Cleef & Arpels





ГЕММОЛОГИЧЕСКАЯ
АКАДЕМИЯ



© Van Cleef & Arpels



ГЕММОЛОГИЧЕСКАЯ
АКАДЕМИЯ





ГЕММОЛОГИЧЕСКАЯ
АКАДЕМИЯ





ГЕМОЛОГИЧЕСКАЯ
АКАДЕМИЯ





ГЕММОЛОГИЧЕСКАЯ
АКАДЕМИЯ





ГЕММОЛОГИЧЕСКАЯ
АКАДЕМИЯ





ГЕММОЛОГИЧЕСКАЯ
АКАДЕМИЯ





ГЕММОЛОГИЧЕСКАЯ
АКАДЕМИЯ



© Van Cleef & Arpels



ГЕМОЛОГИЧЕСКАЯ
АКАДЕМИЯ



© Van Cleef & Arpels



ГЕММОЛОГИЧЕСКАЯ
АКАДЕМИЯ





ГЕММОЛОГИЧЕСКАЯ
АКАДЕМИЯ





ГЕММОЛОГИЧЕСКАЯ
АКАДЕМИЯ



Van Cleef & Arpels



ГЕМОЛОГИЧЕСКАЯ
АКАДЕМИЯ





ГЕММОЛОГИЧЕСКАЯ
АКАДЕМИЯ

STEPHEN WEBSTER

LONDON





ГЕММОЛОГИЧЕСКАЯ
АКАДЕМИЯ



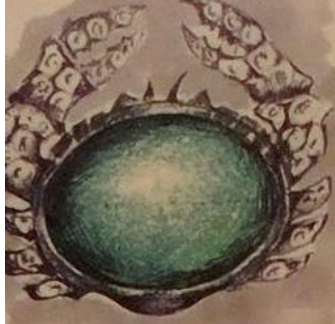

CRAB RING

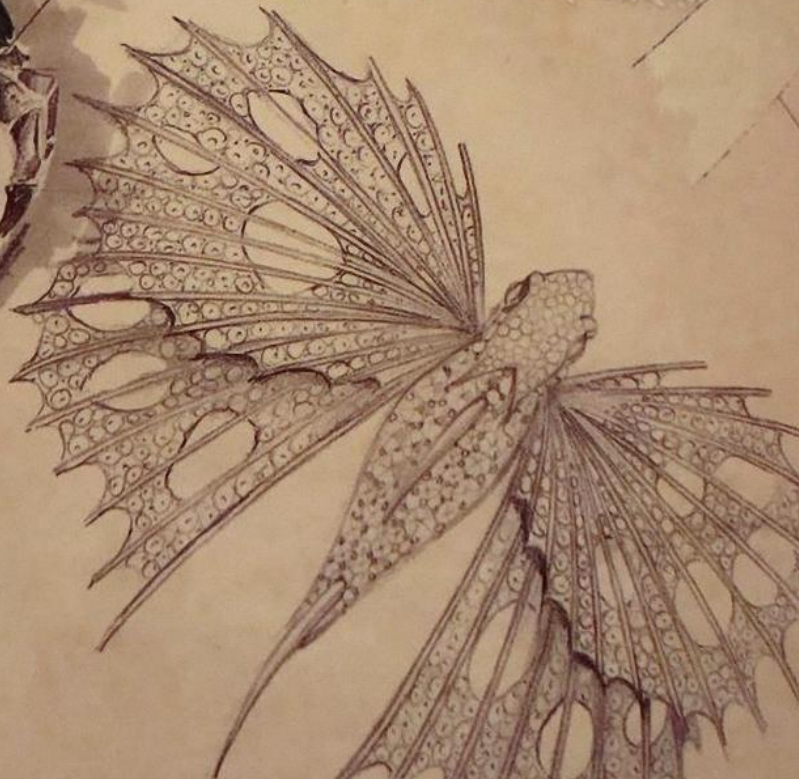



ГЕММОЛОГИЧЕСКАЯ
АКАДЕМИЯ

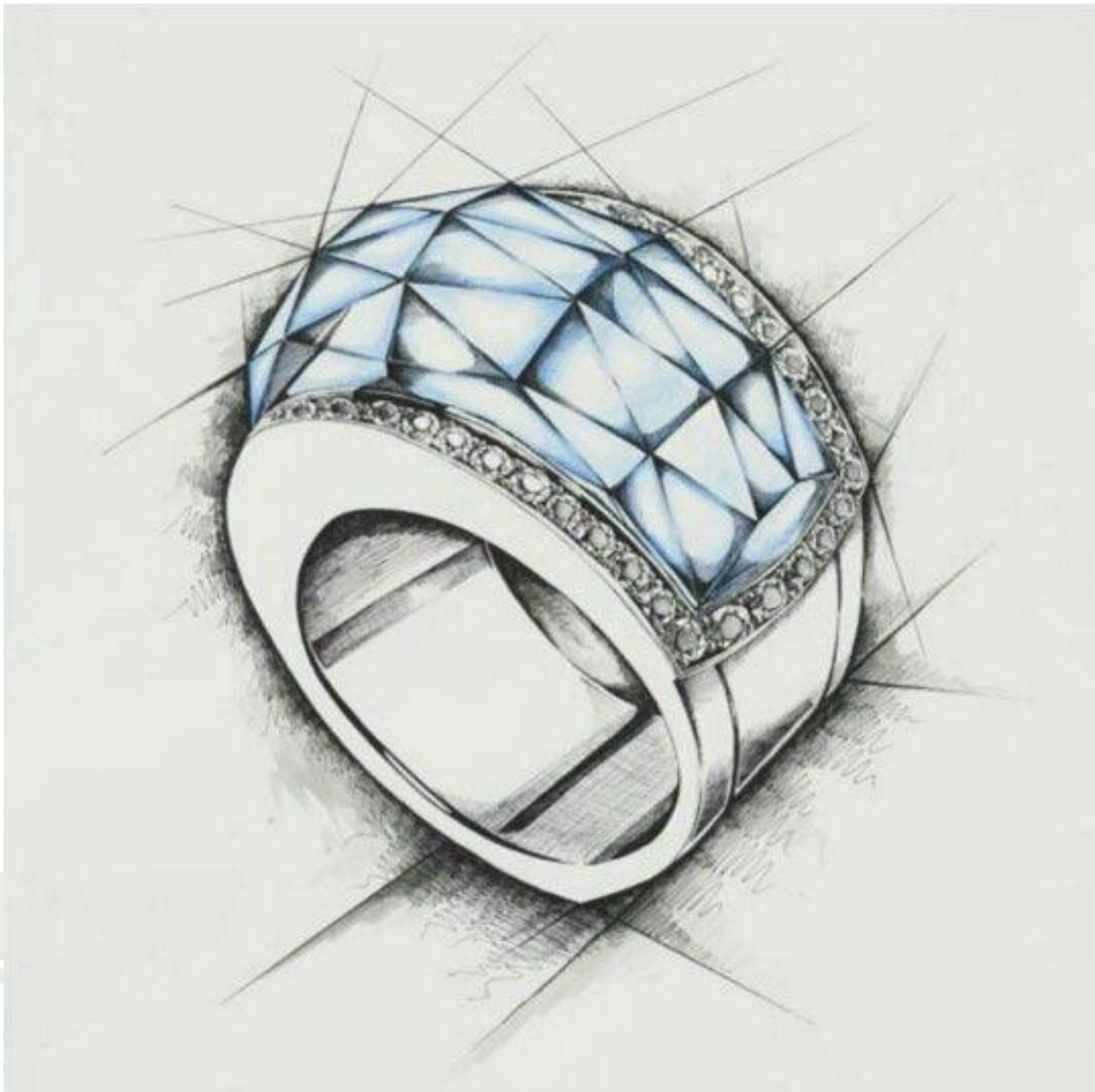



ГЕМОЛОГИЧЕСКАЯ
АКАДЕМИЯ





ГЕММОЛОГИЧЕСКАЯ
АКАДЕМИЯ





ГЕММОЛОГИЧЕСКАЯ
АКАДЕМИЯ





ГЕММОЛОГИЧЕСКАЯ
АКАДЕМИЯ





ГЕММОЛОГИЧЕСКАЯ
АКАДЕМИЯ





ГЕММОЛОГИЧЕСКАЯ
АКАДЕМИЯ





ГЕММОЛОГИЧЕСКАЯ
АКАДЕМИЯ





ГЕММОЛОГИЧЕСКАЯ
АКАДЕМИЯ

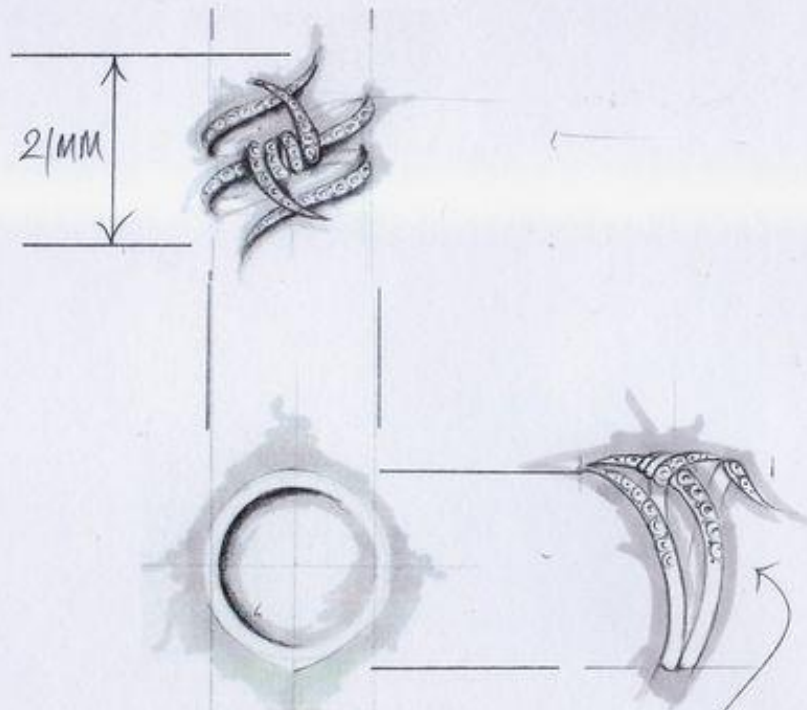

TAPERED ROUND
WIRE, SET WITH
BLACK OR WHITE
DIAMONDS



ГЕММОЛОГИЧЕСКАЯ
АКАДЕМИЯ

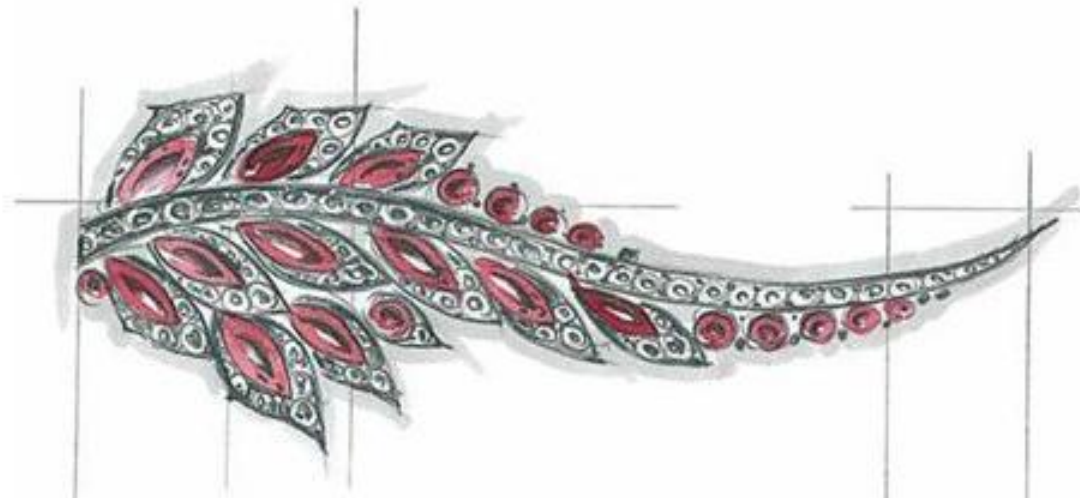



ГЕММОЛОГИЧЕСКАЯ
АКАДЕМИЯ





ГЕМОЛОГИЧЕСКАЯ
АКАДЕМИЯ





ГЕММОЛОГИЧЕСКАЯ
АКАДЕМИЯ





ГЕММОЛОГИЧЕСКАЯ
АКАДЕМИЯ



Круглая



Груша

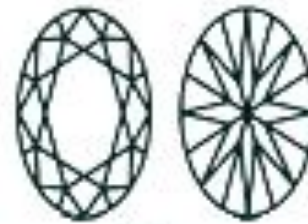

Овал



Маркиз



Сердце



Принцесса

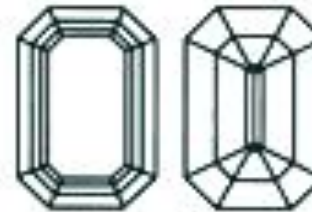

Изумруд

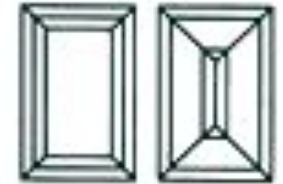

Багет

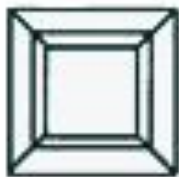

Квадрат



Восьмиугольник

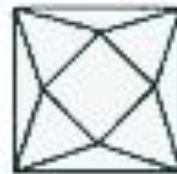

Французская



Шар

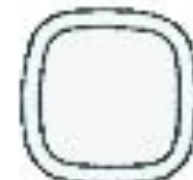

Античная



Челночок



Капля



Бриолет



Бочка



Трапеция



Щит



ГЕМОЛОГИЧЕСКАЯ
АКАДЕМИЯ

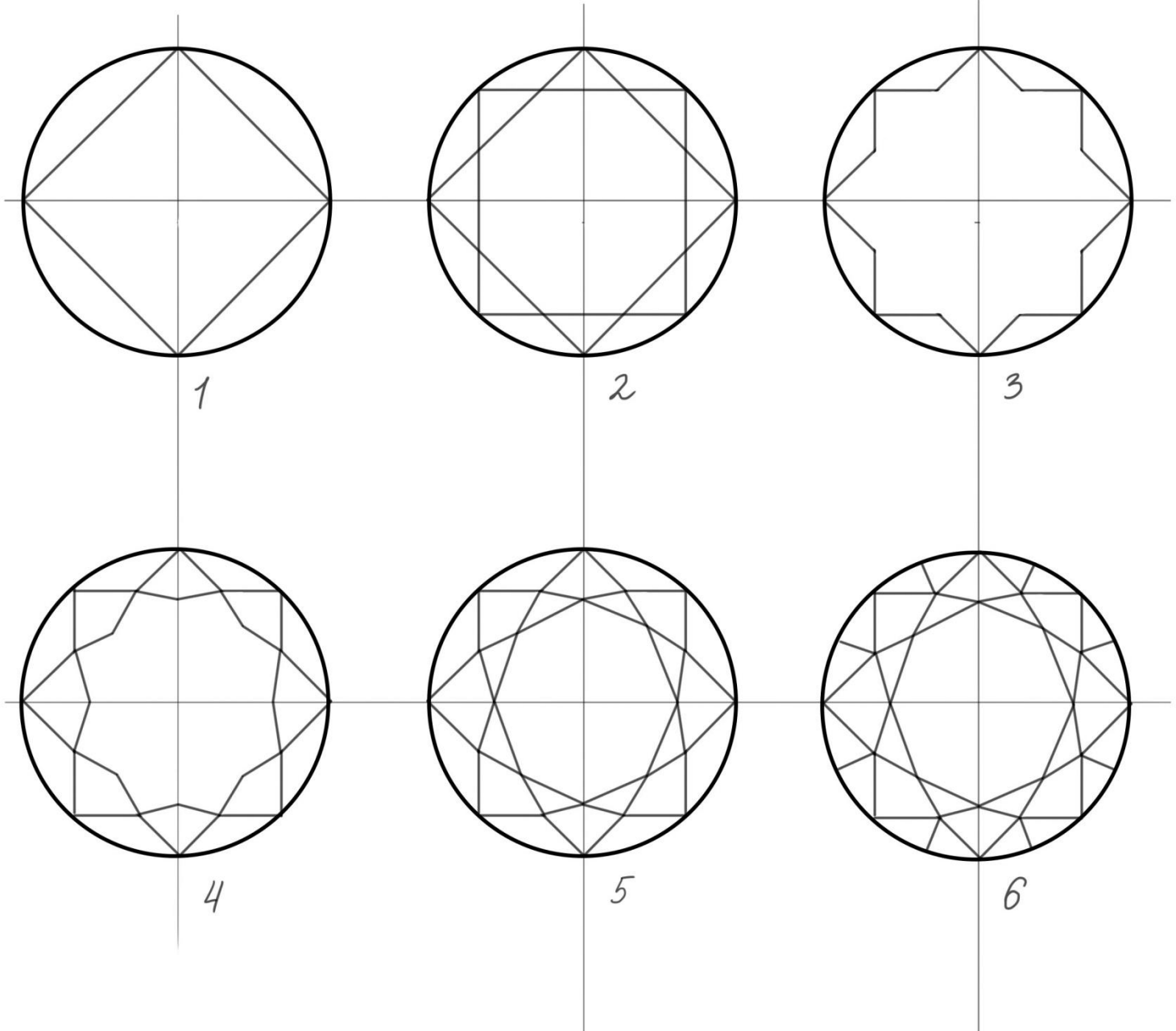



ГЕММОЛОГИЧЕСКАЯ
АКАДЕМИЯ

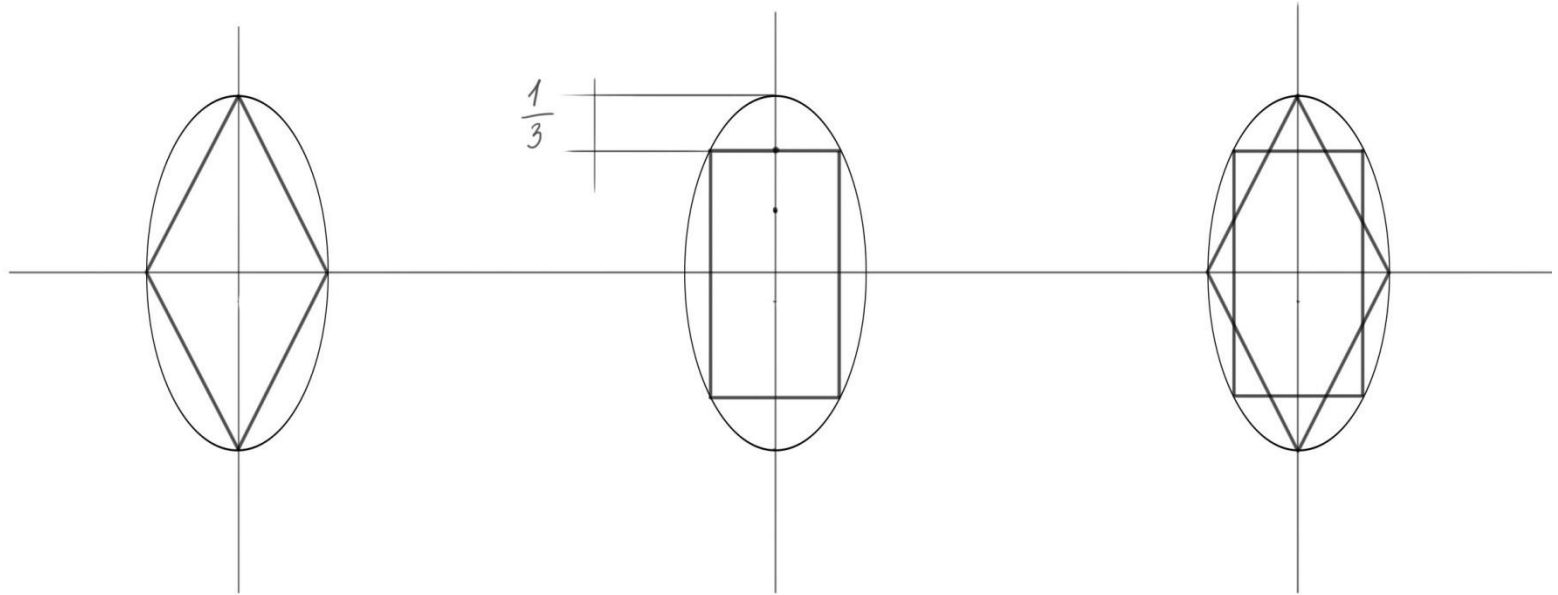



ГЕММОЛОГИЧЕСКАЯ
АКАДЕМИЯ

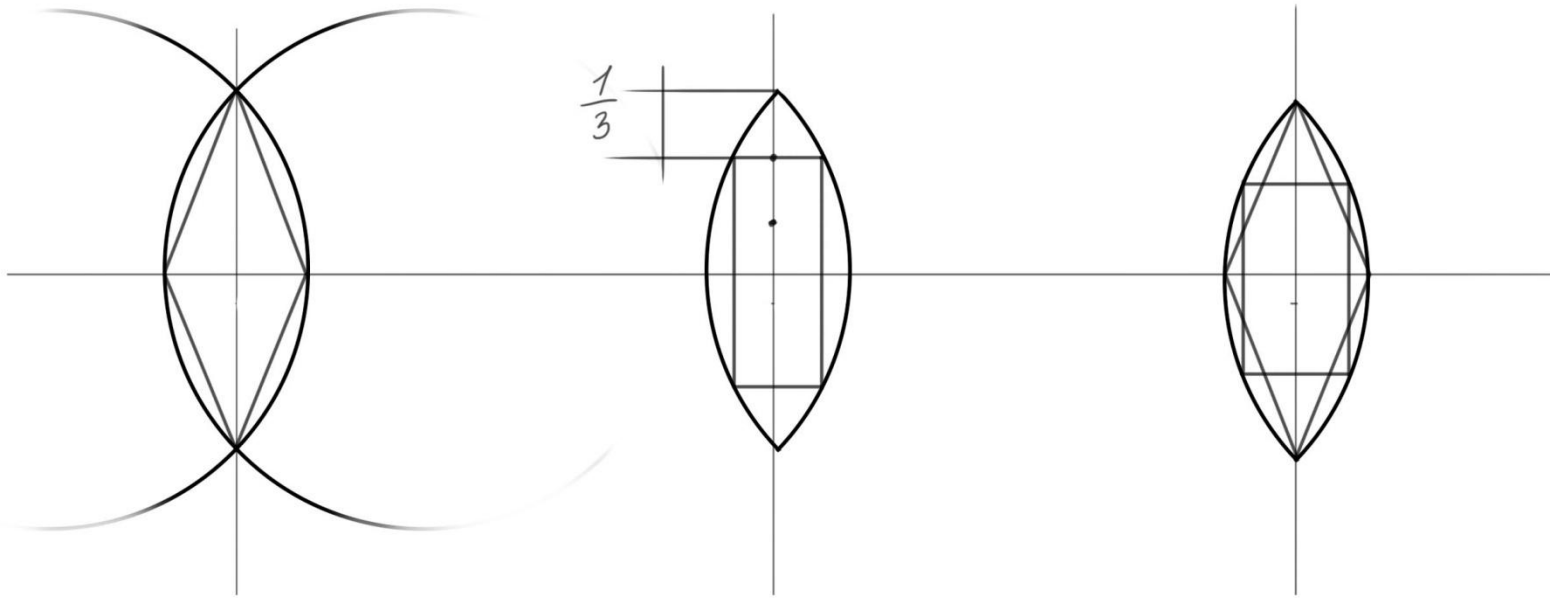



ГЕММОЛОГИЧЕСКАЯ
АКАДЕМИЯ

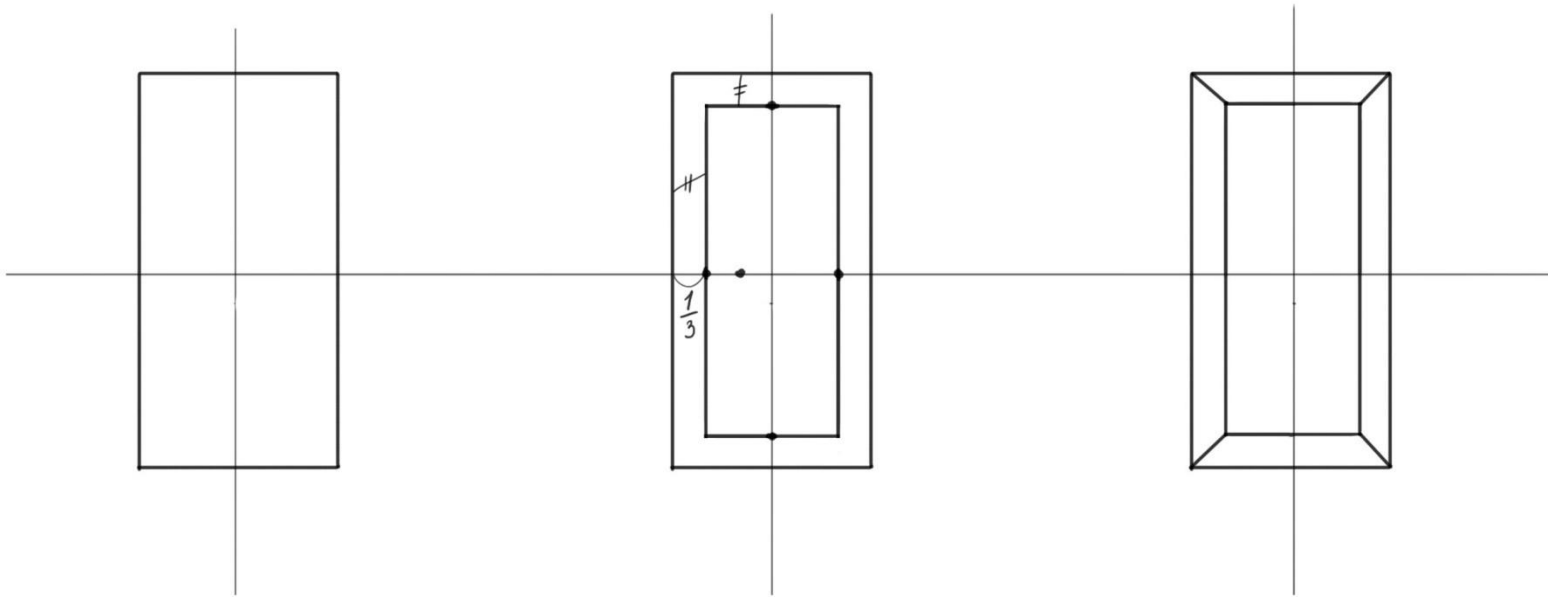



ГЕММОЛОГИЧЕСКАЯ
АКАДЕМИЯ

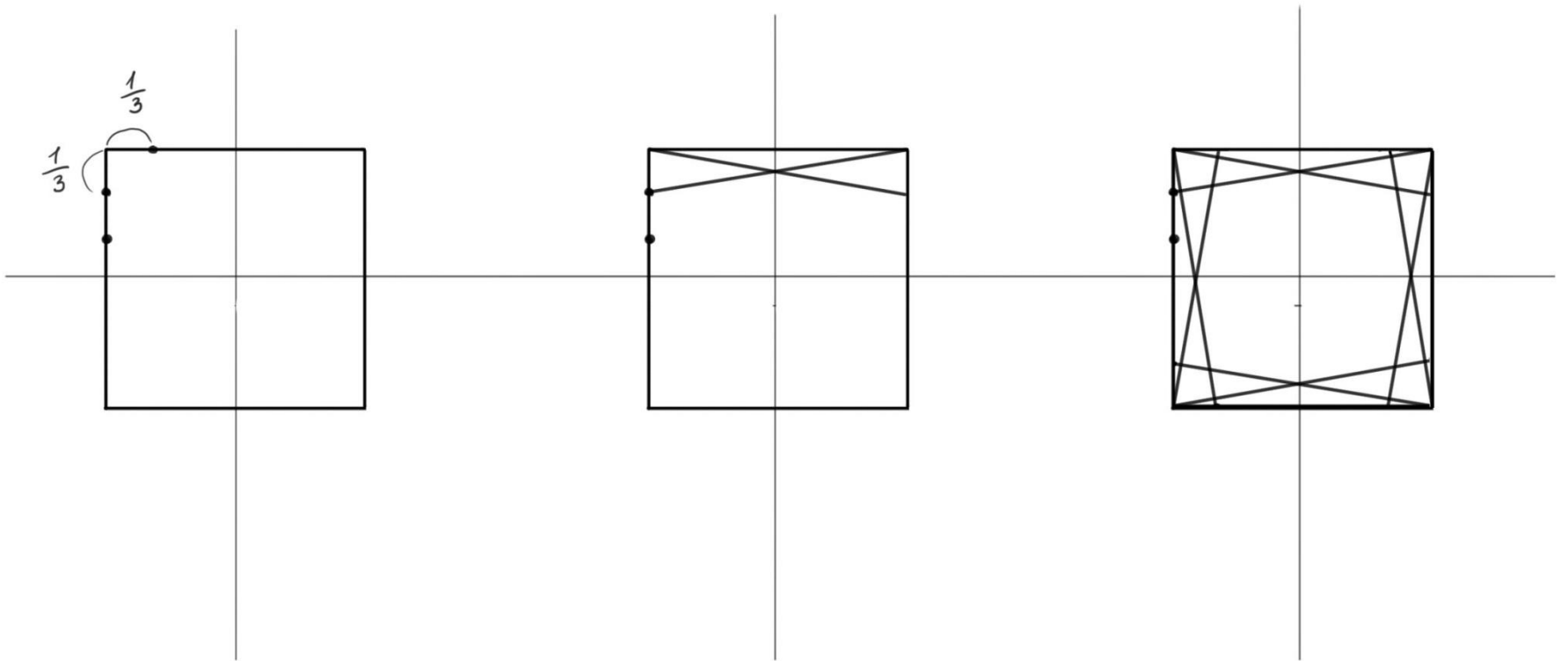



ГЕМОЛОГИЧЕСКАЯ
АКАДЕМИЯ

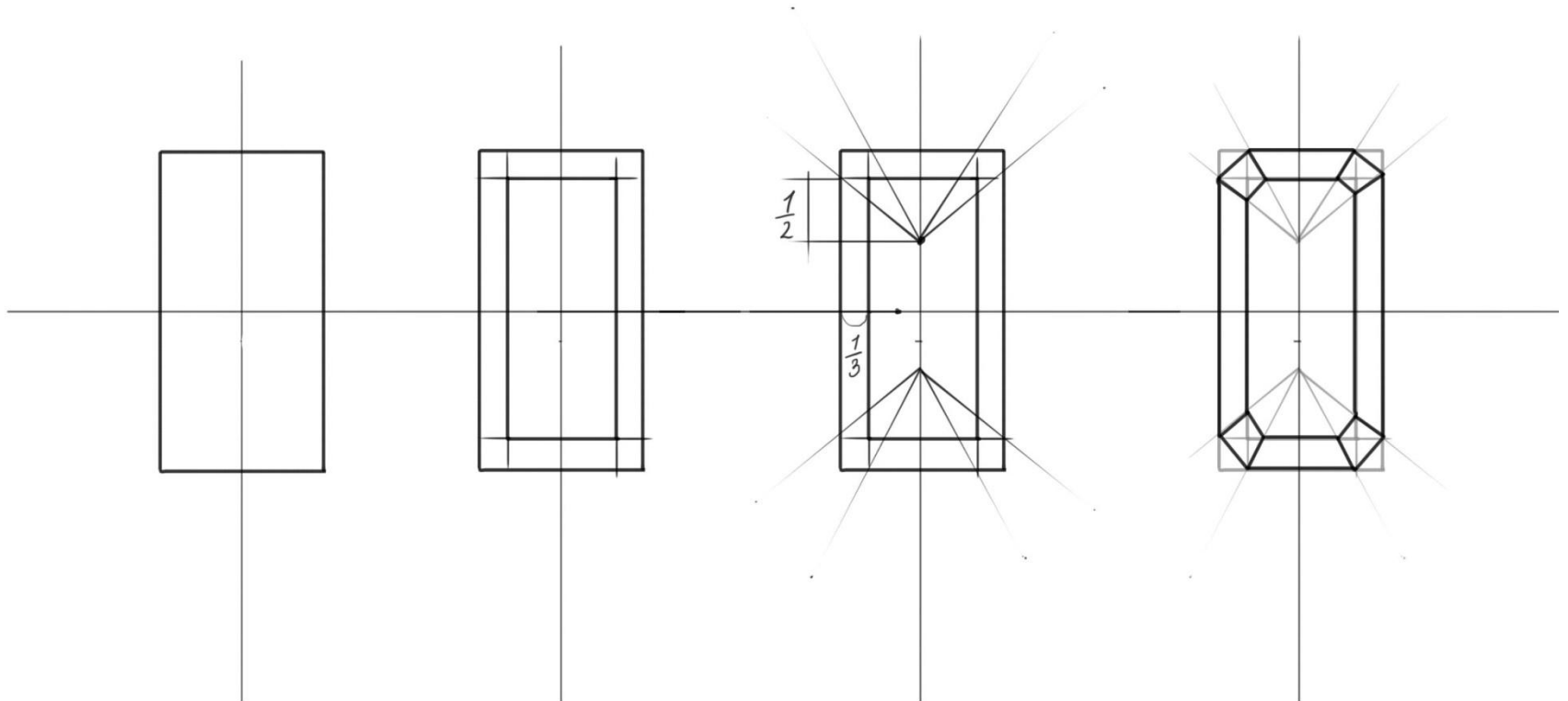



ГЕМОЛОГИЧЕСКАЯ
АКАДЕМИЯ

