

КОНСТРУКЦИЯ: ЧАСТЬ И ЦЕЛОЕ

ЗДАНИЕ КАК СОЧЕТАНИЕ РАЗЛИЧНЫХ
ОБЪЕМОВ

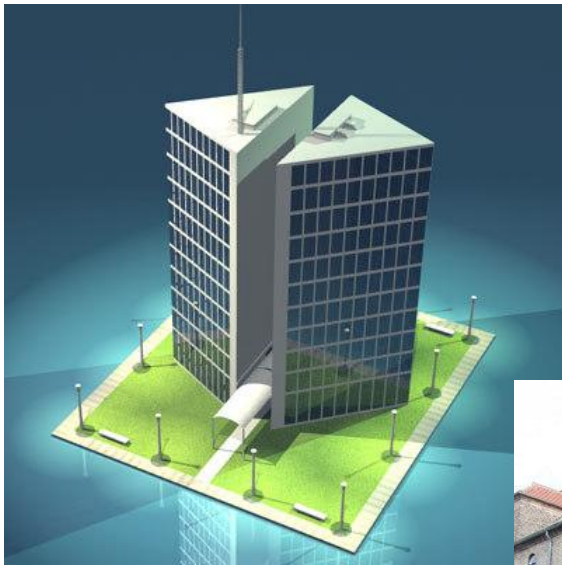

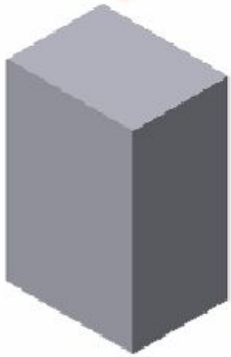

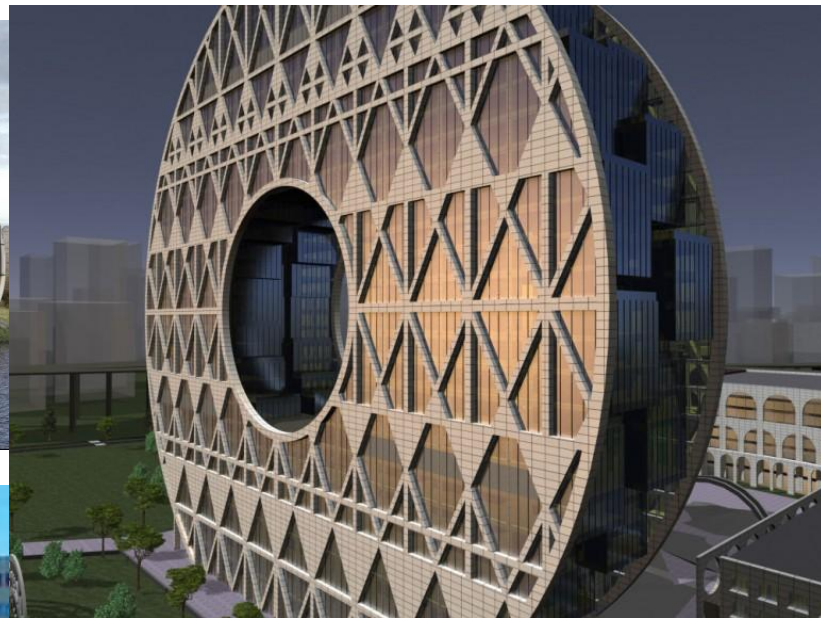

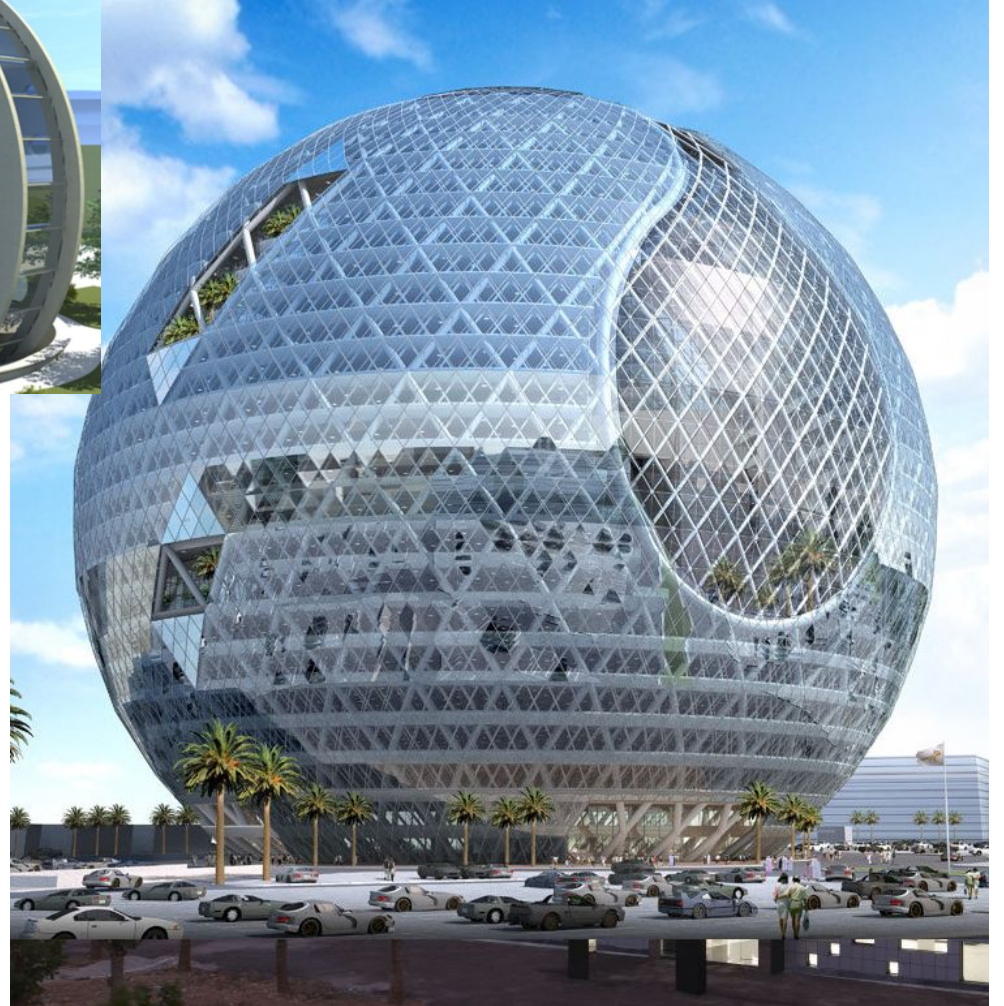



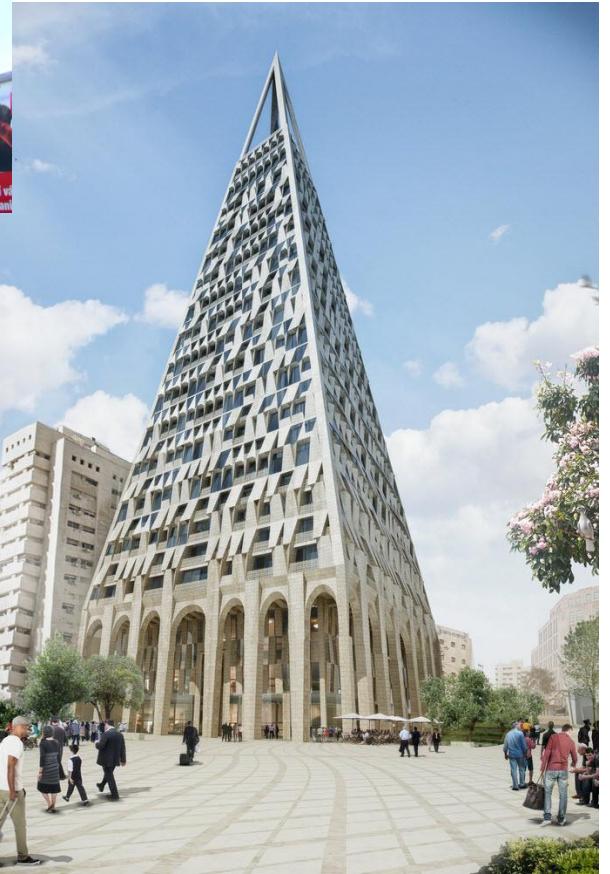

Сочетание различных объемов



По виду композиции внешние объемы зданий могут быть простыми, состоящими из одного объема, и сложными — из двух и более объемов разной формы.





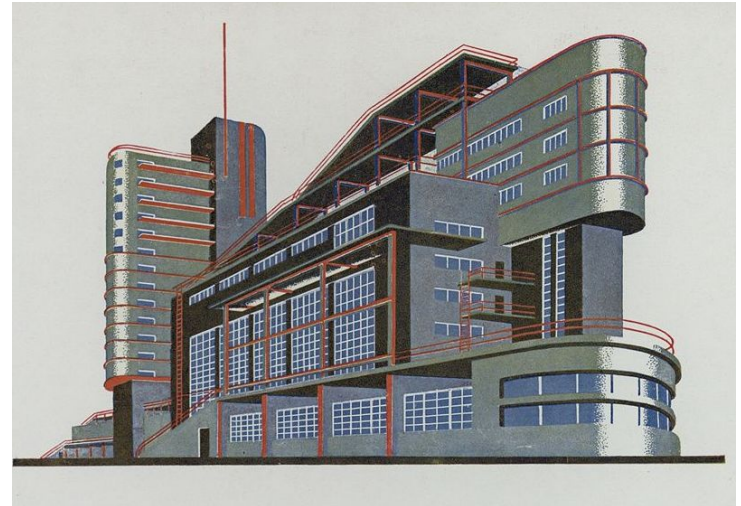

Архитектурная композиция,
которая состоит из нескольких зданий называется
архитектурный комплекс



Центр международной
торговли.



Модуль (от лат. *modulus* — мера) в архитектуре, условная единица, принимаемая для координации размеров частей здания или комплекса



ОТ ПЛОСКОСТНОГО ИЗОБРАЖЕНИЯ К ОБЪЕМНОМУ МАКЕТУ

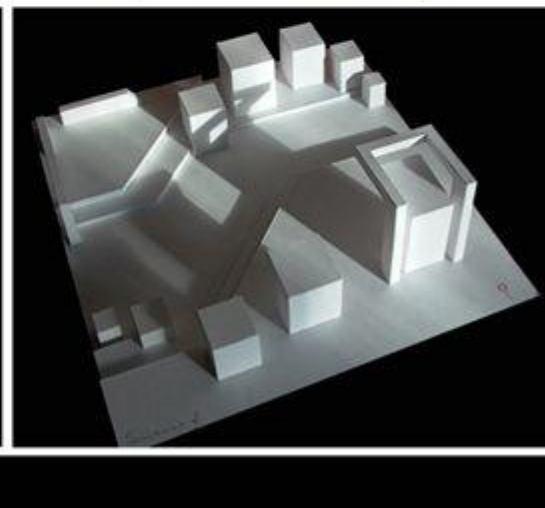
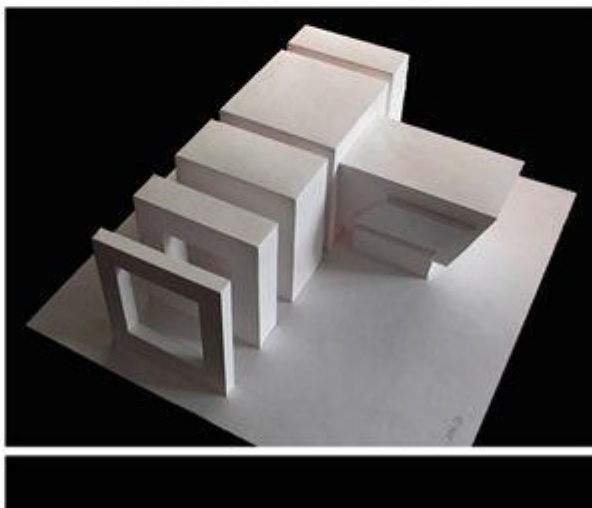
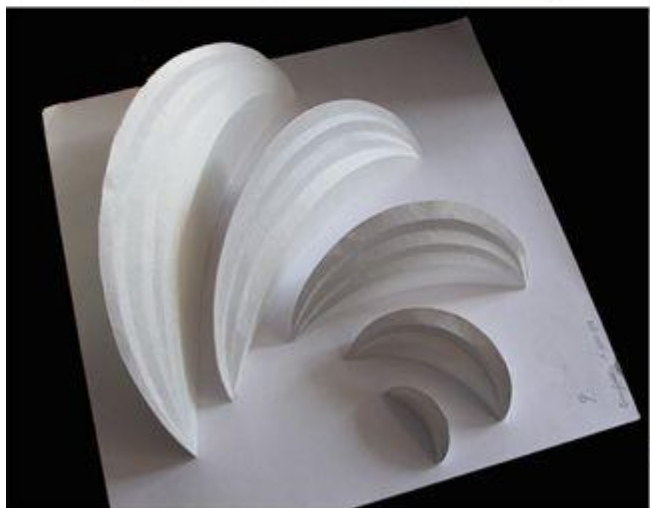
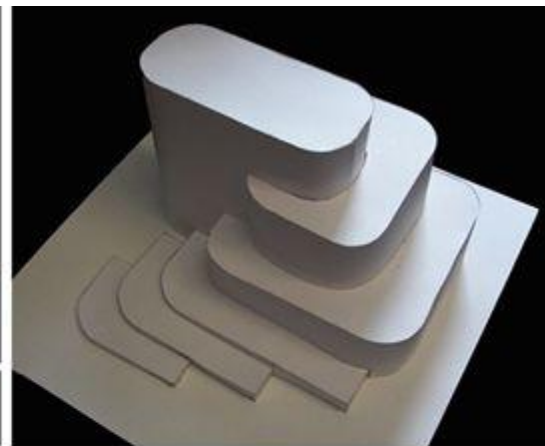

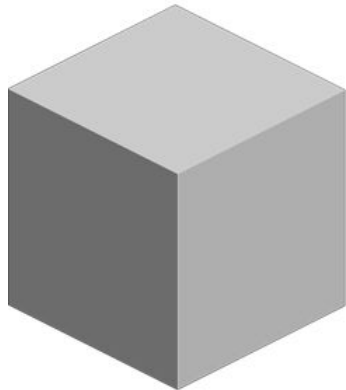

Первое и главное мерило
всему в
архитектуре и дизайне-
ЧЕЛОВЕК



Эргономика – наука, основанная на физиологии, технике и психологии того, как люди взаимодействуют со своей рабочей средой. Цель данной науки, это предоставление рекомендаций по повышению эффективности и комфорта при обустройстве рабочей среды.

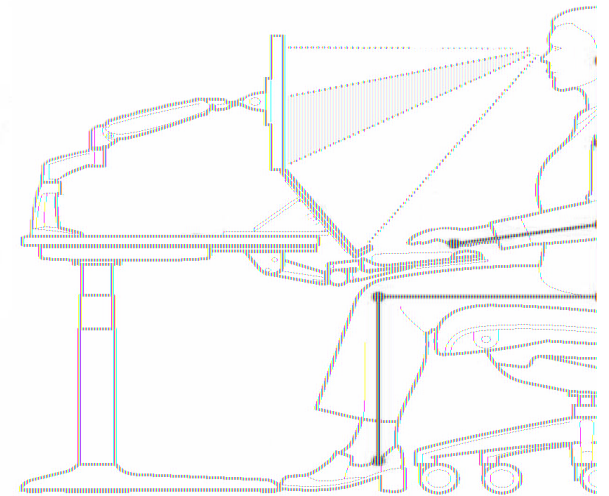
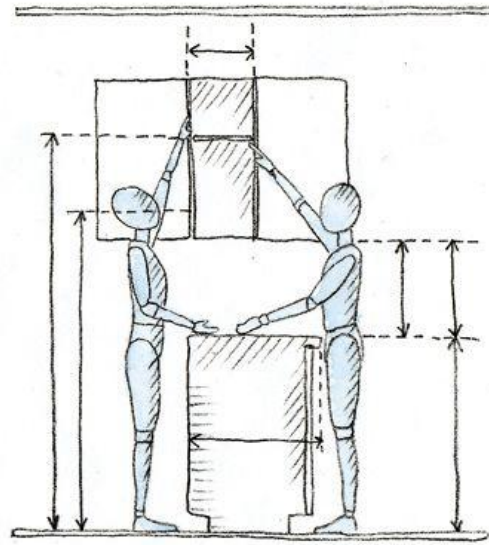
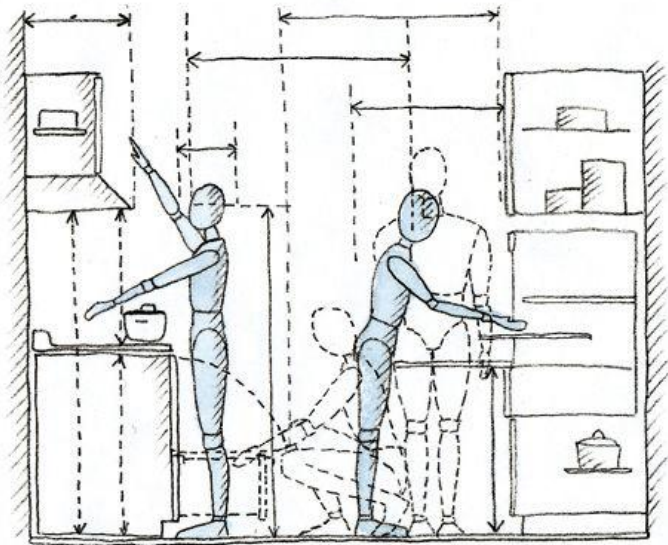

ПРОПОРЦИОНАЛЬНОСТЬ- важнейшее определение в архитектуре.

Оно характеризует тектонику здания, т.е. соотношение высоты,

ширины, сор
отно
дру

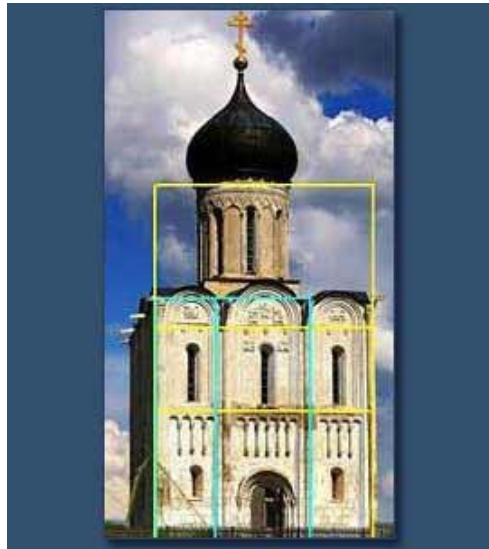
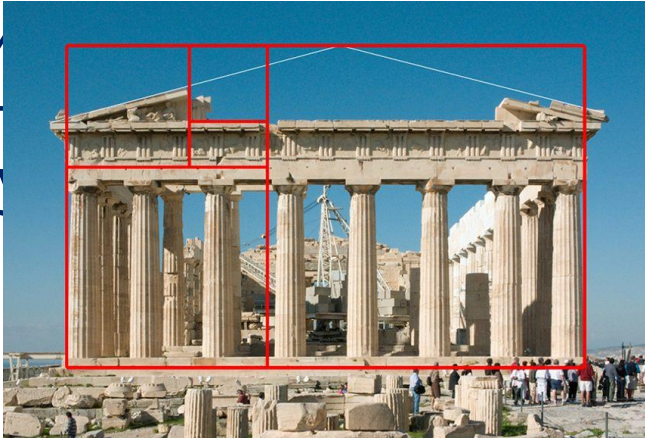

СОРАЗМЕРНОСТЬ группы зданий







