



ROSATOM

ROSATOM TECHNICAL ACADEMY



Rosatom Tech

Steam generator blowdown system



scale-forming substances:
Ca+Mg; FeO₂

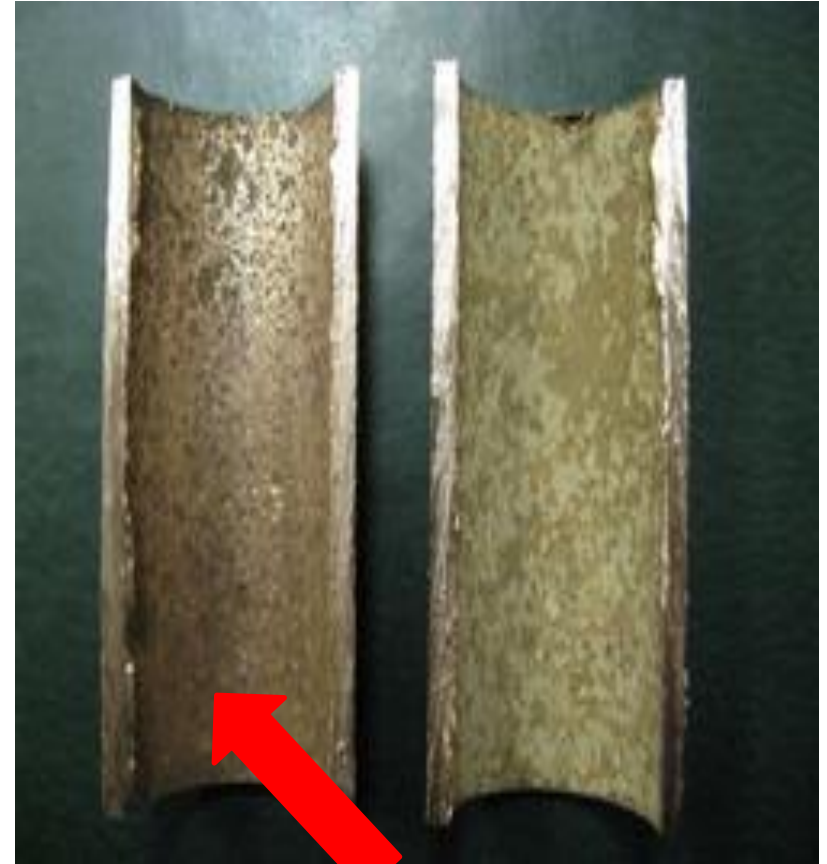

Corrosion appeared after scale
deposit

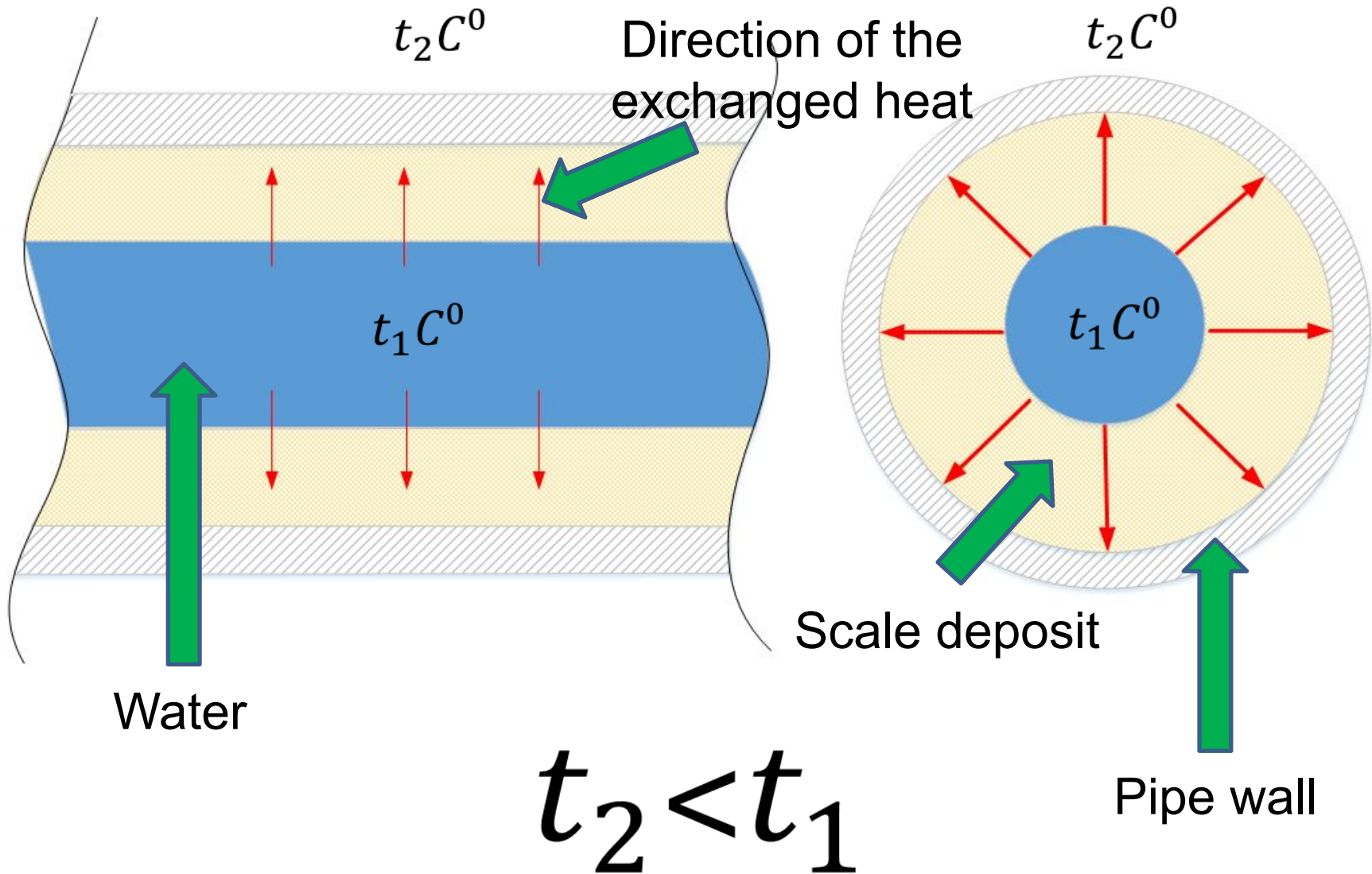

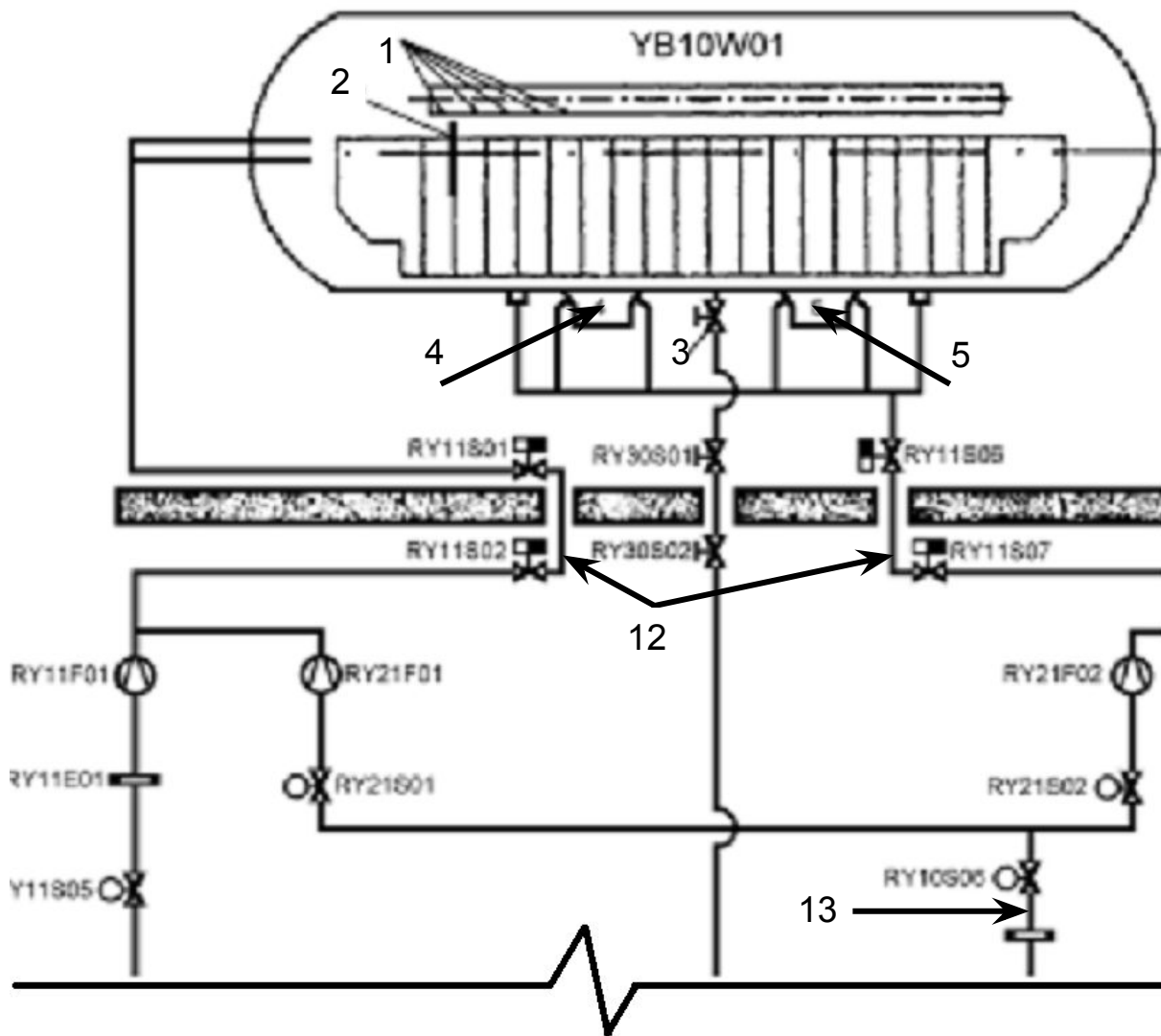

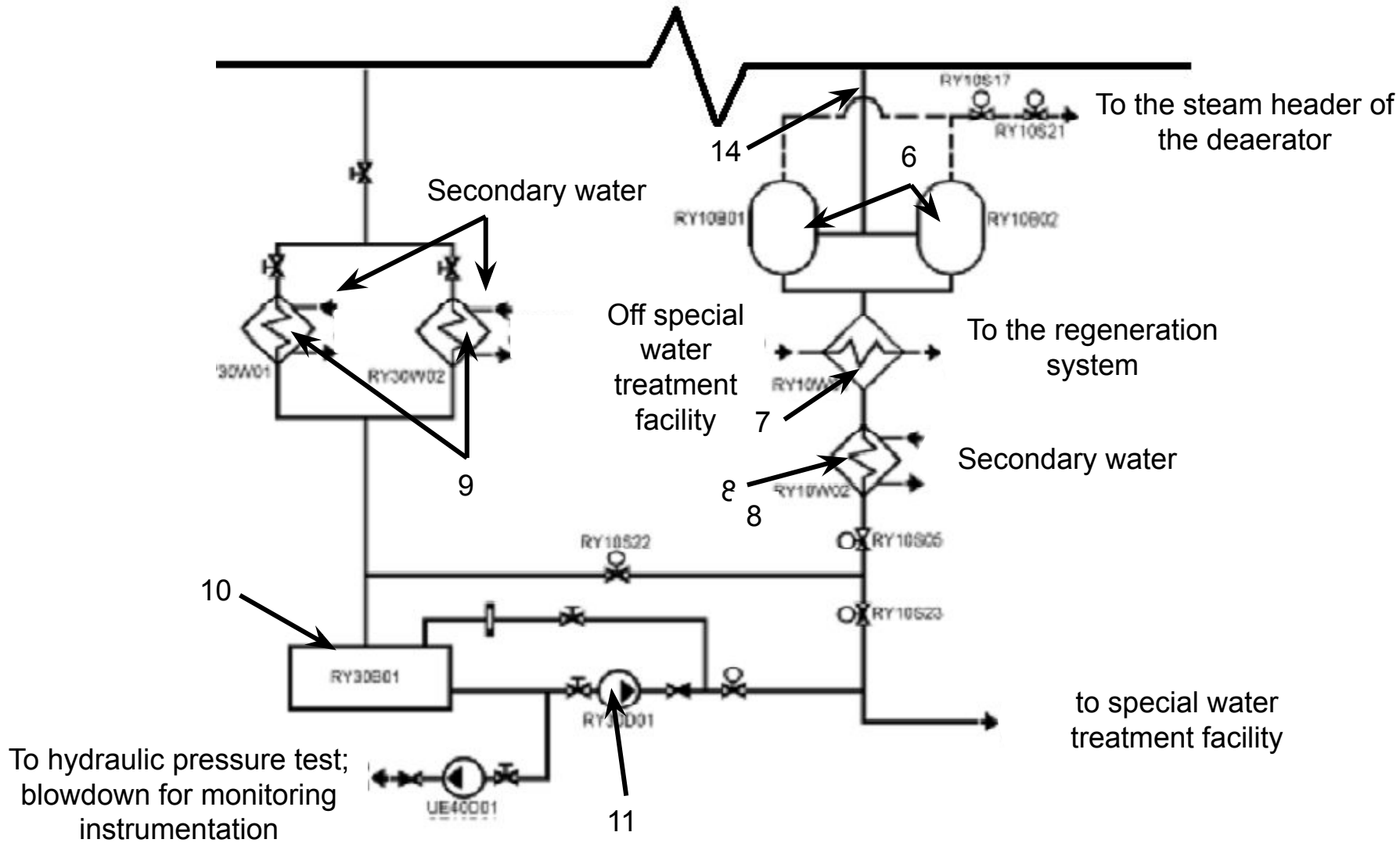

Thanks for your
attention