



Unit 1: Drawings

Dr. Basil Hamed
Technical English

Islamic University of Gaza
February, 2017

Vocabulary

detail	التفاصيل
Elevation	ارتفاع
General arrangement (GA)	الترتيب العام
Plan	خطة
Scale	مقياس
Schematic	تخطيطي
Section	الجزء
oblique projection	إسقاط منحرف
Isometric projection	القياس الإسقاط متساوي

Exploded View is technical drawing of an object, that shows the relationship or order of assembly of various parts.

Outline

- A. Drawing types and scales
- B. Types of views used on drawings

A. Drawing types and scales

In engineering, most design information is shown on drawings. **Today**, drawings are generally not drawn by hand. They are produced on computer, using CAD (**computer-aided design**) systems.

A. Drawing types and scales

A key factor on a drawing is the **scale** - that is, the size of items on the drawing in relation to their real size. When all the items on a drawing are shown relative to their real size, the drawing is drawn to scale, and can be called **a scale drawing**.

An example of a scale is 1:10 (one to ten). At **1:10**, an object with a length of 100 mm in real life would measure 10 mm on the drawing.

A. Drawing types and scales

Most engineering designs consist of a set of drawings (a number of related drawings):

- **General arrangement (GA)** drawings show whole devices or structures, using a small scale. This means objects on the drawing are small, relative to their real size (for example, a **1:100 drawing of an entire building**).
- Detail drawings show parts in detail, using a large scale, such as **1:5 or 1:2**. Small parts are sometimes shown in a detail as actual size (**1:1**), or can be enlarged to bigger than actual size (for example, **2:1**).

A. Drawing types and scales

For electrical circuits, and pipe and duct networks, it is helpful to show designs in a simplified form. In this case, schematic drawings (often referred to as schematics) are used. An everyday example is the map of a train network.

Notes: When written, drawing is often abbreviated to dwg.

B. Types of views used on drawings

Technicians are discussing different views shown on drawings (looking at components from above, from the side, etc.), as they search for the information they require.

- We need a view from above showing -the **general arrangement** of all of -the roof panels - a plan of -the whole area.
- According "to this list, -there are of all **elevation** four sides of -the machine on drawing 28. So one of Those should show the front of the machine.

B. Types of views used on drawings

- There should be a **section** Through the pipe, showing the valve Inside, on drawing 36.
- We need an **exploded view** of -the mechanism, showing -the components spaced out.
- It's hard "to visualize This assembly, based on **two-dimensional** elevations and sections. It would be clearer if we had a **three-dimensional** view, as either an **oblique projection** or an **Isometric projection**.

Appendix I Three-dimensional drawings

An oblique projection shows an object with one of its faces at the front. The 3D shape of the object is shown by lines at 45 degrees from the horizontal.

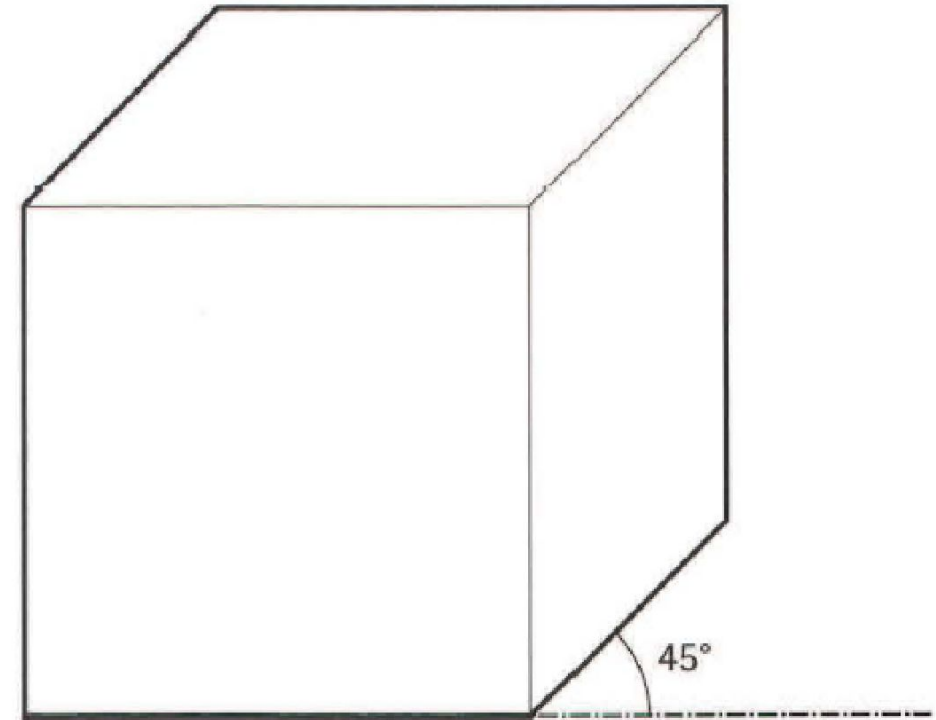

Appendix I Three-dimensional drawings

An isometric projection shows an object with one of its corners at the front. The 3D shape of the object is shown by lines at 30 degrees from the horizontal.

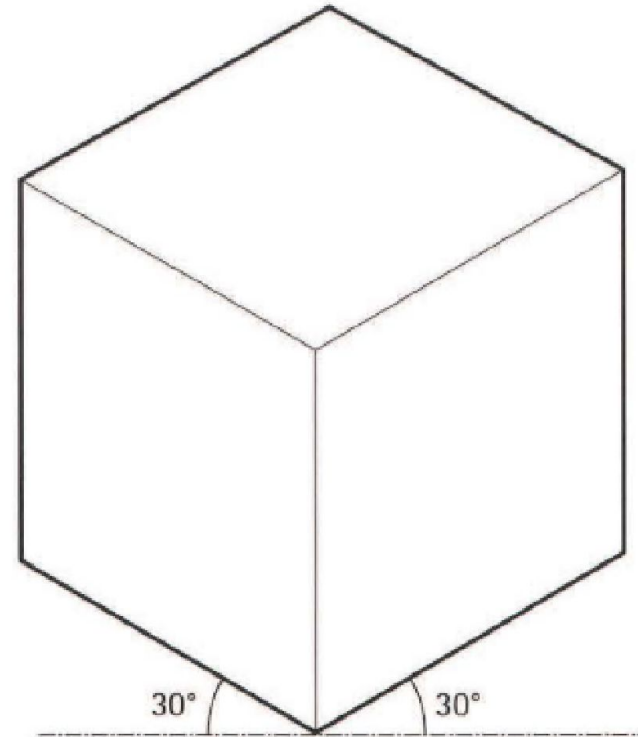

Appendix I Three-dimensional drawings

An exploded view shows an assembly with its components spaced out, to show how the components fit together.

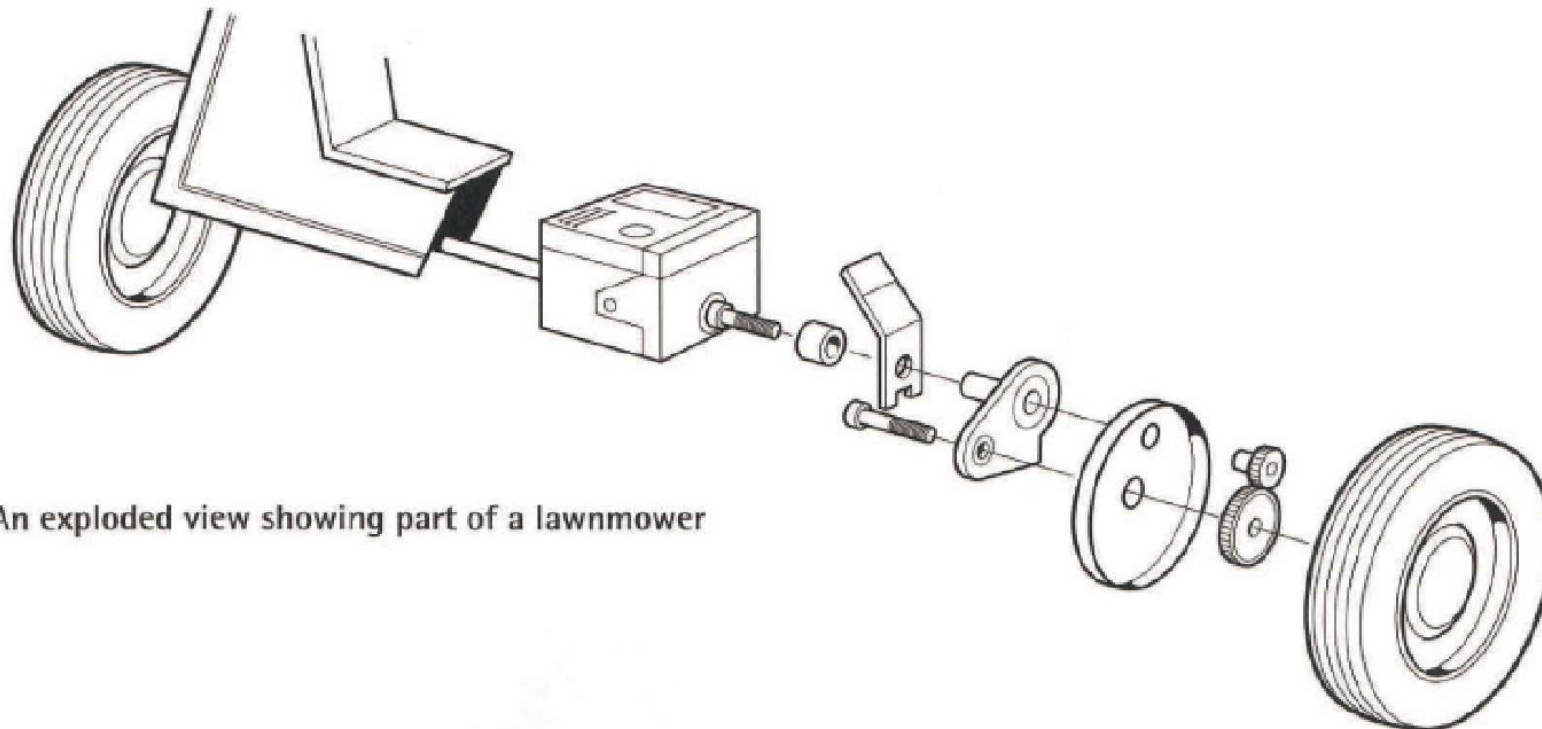

An exploded view showing part of a lawnmower

Exercise

1.1 Complete the sentences. Look at A opposite to help you

1. Enlarged drawings show components larger than their
- 2 For engineering drawings, 1:5 is a commonly used
- 3 Whole machines or structures are shown on drawings.
- 4 Electrical drawings don't usually show sizes. They're shown as
- 5 A of drawings for a large project can consist of hundreds of pages.
- 6 Most drawings are produced on computers, using software.

1 actual size

2 scale

3 general arrangement

4 schematics

5 set

6 CAD

Exercise

1.2 Match the descriptions (1-6) with the names of views used on drawings (a-f). Look at B opposite and Appendix I on page 98 to help you.

- 1 a 2D view of the side of an object
- 2 a 2D view inside an object, as if it is cut through
- 3 a 2D view, looking down on top of an object
- 4 a 3D view, showing an assembly taken to pieces
- 5 a 3D view, with the 2D face of the object at the front
- 6 a 3D view, with a corner of the object at the front

- a a plan
- b a section
- c an isometric projection
- d an oblique projection
- e an exploded view
- f an elevation

1f, 2b, 3a, 4e, 5d, 6c

Exercise

1.3 Write the full forms, in words, of the abbreviations and shortened terms below. Look at A and B opposite and Appendix I on page 98 to help you.

- 1 GA
- 2 CAD
- 3 dwg
- 4 3D
- 5 section
- 6 1:50

- 1 general arrangement
- 2 computer-aided design
- 3 drawing
- 4 three-dimensional
- 5 cross-section
- 6 one to fifty

Exercise

1.4 Complete the sentences, taken from conversations about drawings, using the words and abbreviations in the box. Look at A and B opposite

3D detail elevation GA plan scale schematic section

- 1 We need a through the bridge, showing the profile of the deck.
- 2 The only drawing we have is the, which is 1:100, so it obviously doesn't show things in detail.
- 3 On drawing 12, there's a large of the entire top deck of the ship.
- 4 This is the showing the front face of the tower.
- 5 Modern CAD systems can produce drawings that look almost as realistic as photographs.
- 6 We don't need dimensions and positions at this stage. We just need a showing how many branches come off the main supply pipe.
- 7 We don't have a proper drawing. We've just got a rough sketch, which is not to
- 8 The fixings aren't shown on the 1:50 general arrangement. But there's a, at 1:5, on drawing 42.

- 1 section
- 2 GA
- 3 plan
- 4 elevation
- 5 3D
- 6 schematic
- 7 scale
- 8 detail

End of Unit One

