



优立科技

UNIONMOULD

www.mould.me cnmould@china.com[®]

产品问题反馈 Product Feedback

»» 项目编号-Project NO. : UN20177



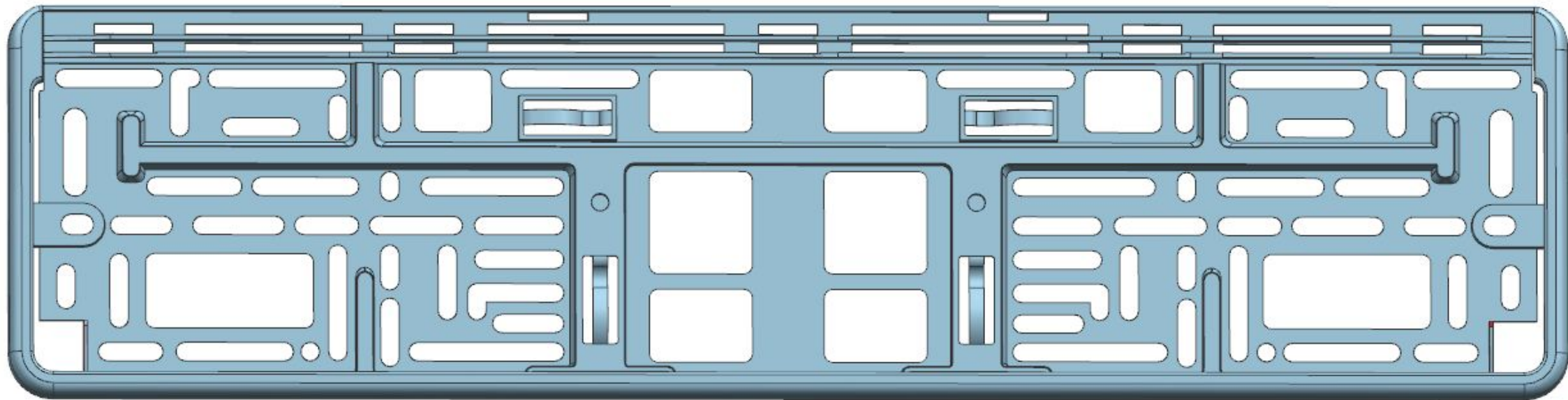

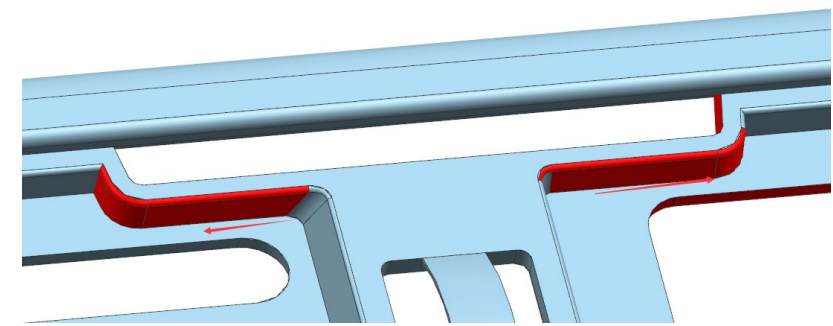
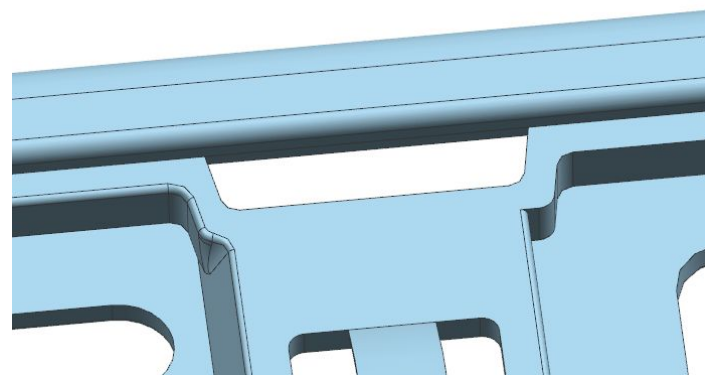
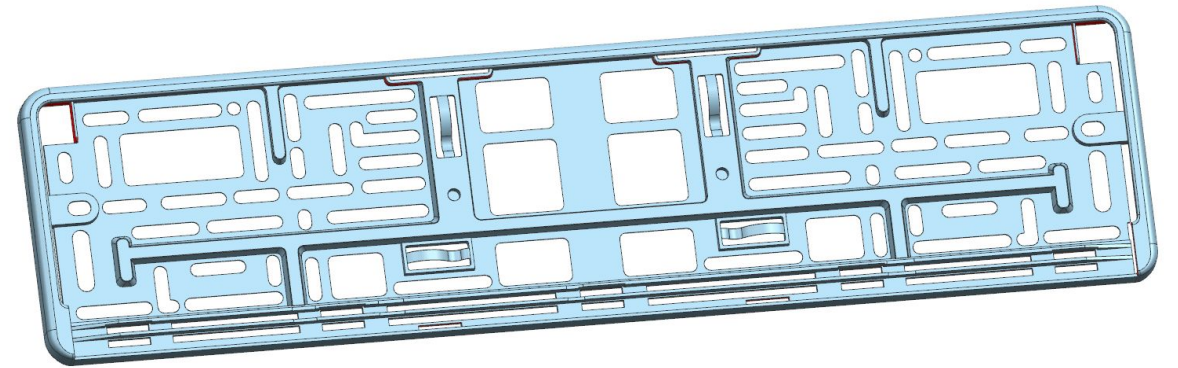
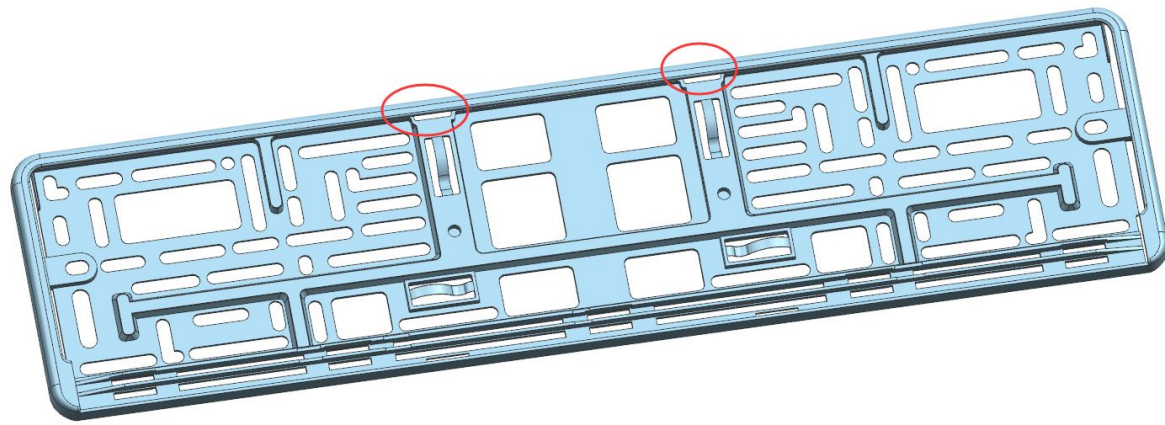

Before-改前

After-改后

From UNION (Author: Erik)

From

Ok/Not

Reply time

如图, 孔每边加大15mm
Can we make Hole length longer by 15mm on both sides ?

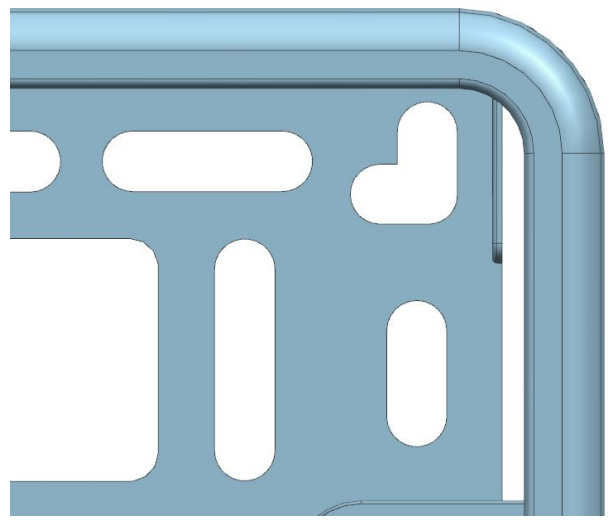
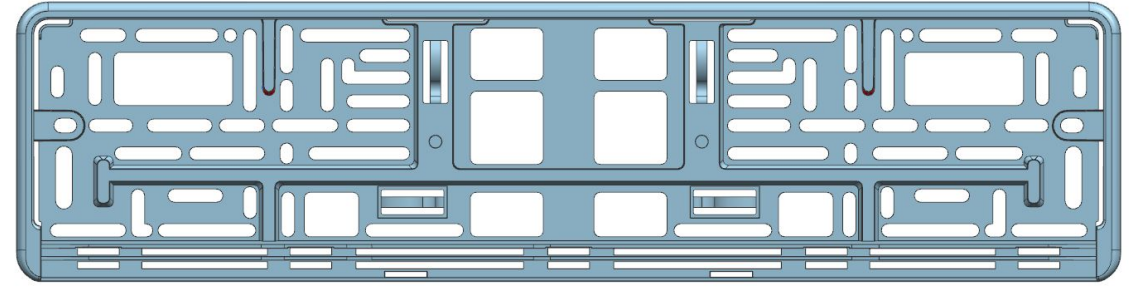
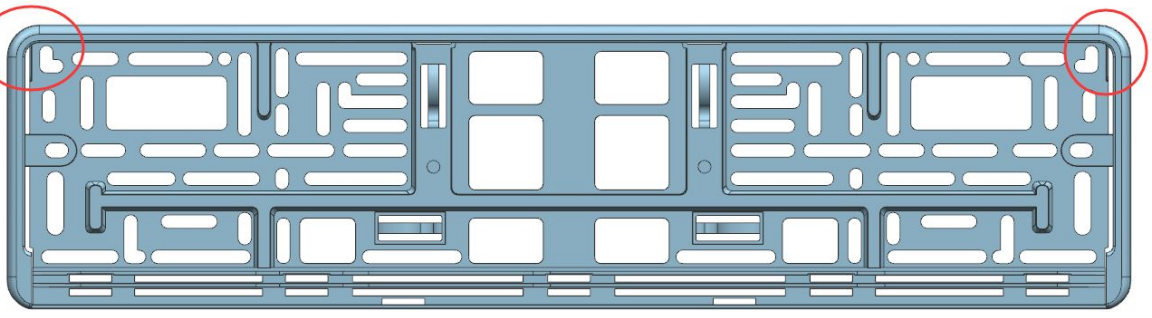

Before-改前

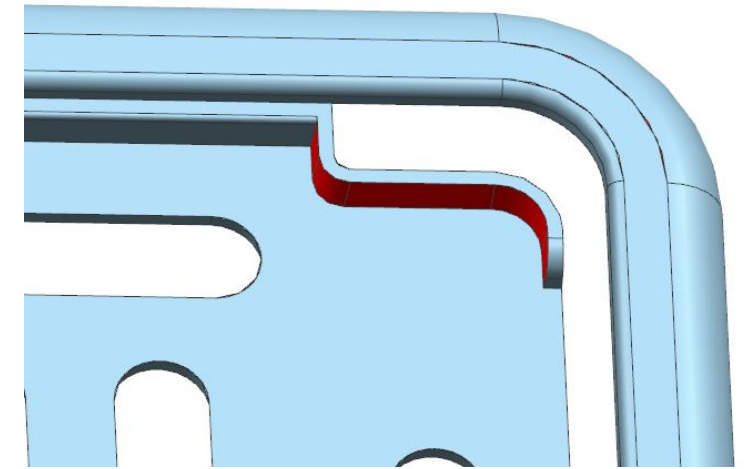

After-改后

From UNION (Author: Erik)

From

Ok/Not

Reply time

如图, 筋位改变
Can we make change on rib design

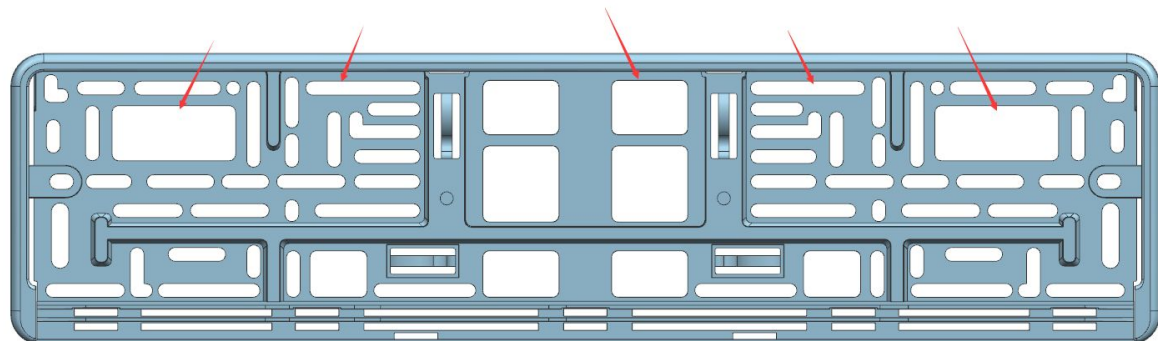

Before-改前

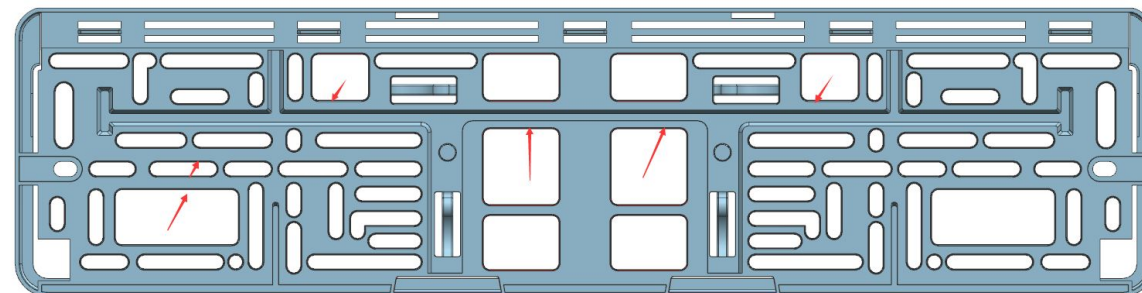

After-改后

From UNION (Author: Erik)

From

Ok/Not

Reply time

如图, 类似的孔, 斜度加大到10度
Can we make hole angle to 10 degree

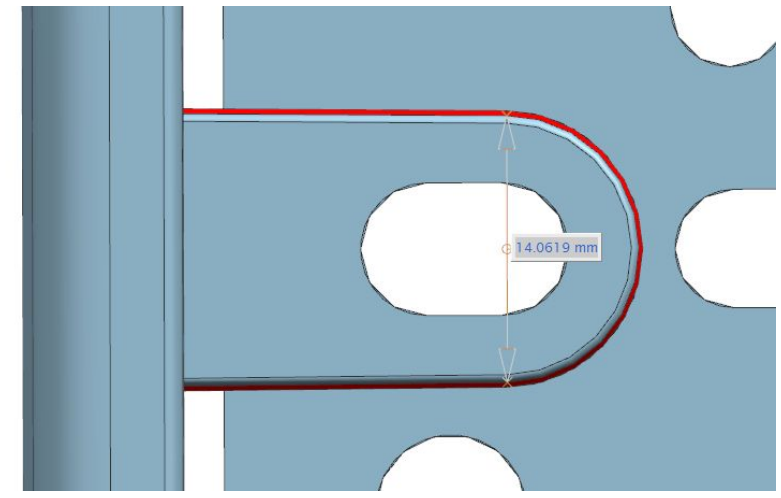
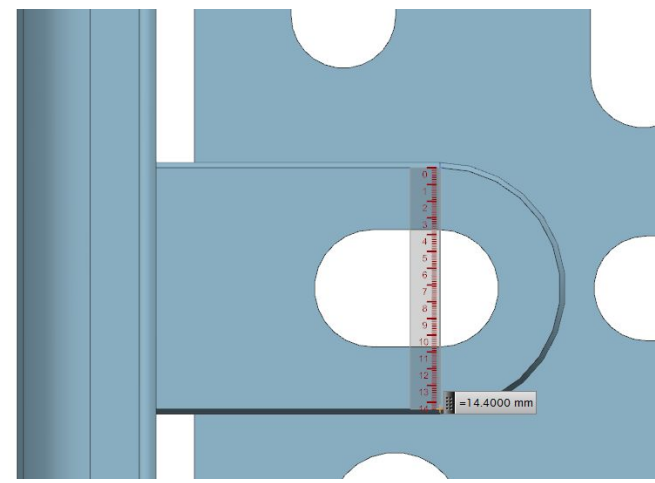
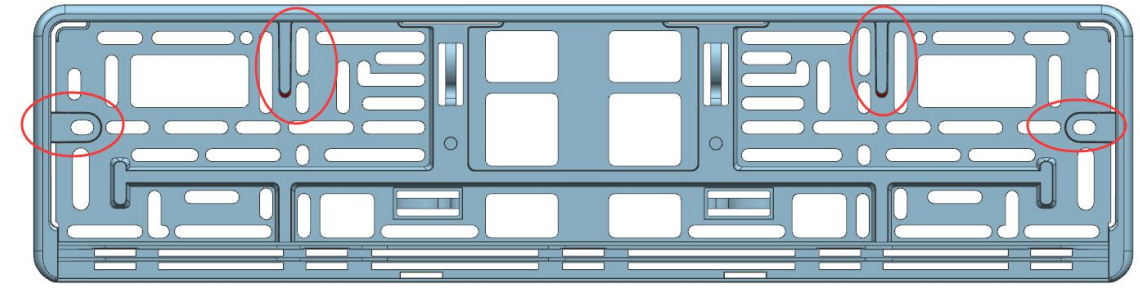
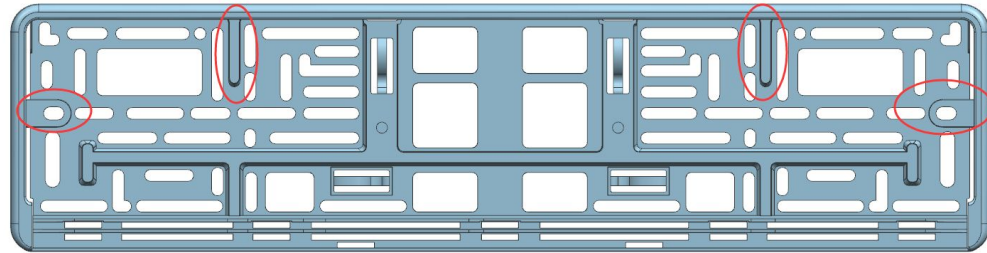

Before-改前

After-改后

From UNION (Author: Erik)

From

Ok/Not

Reply time

如图4个形状头部缩小单边0.2mm方便脱模
Can we reduce by 0.2mm on every side, it will be easier for mold ejection

--	--	--

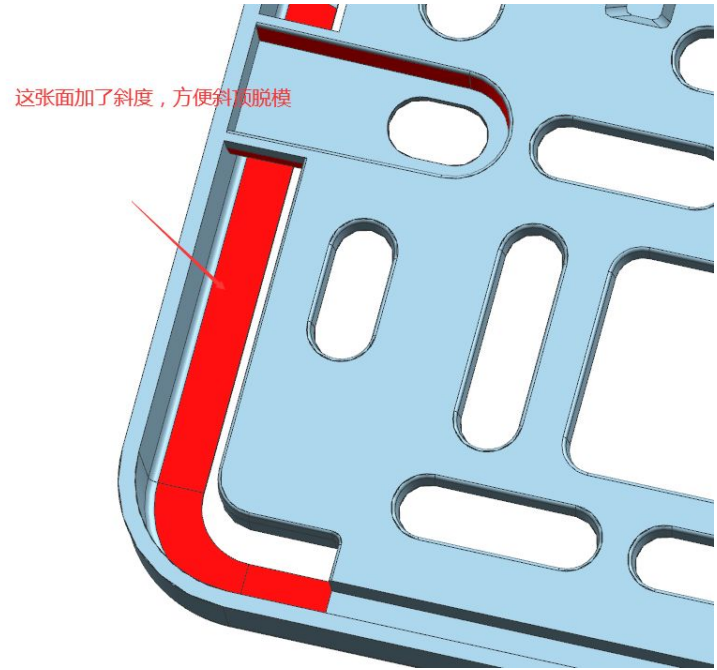
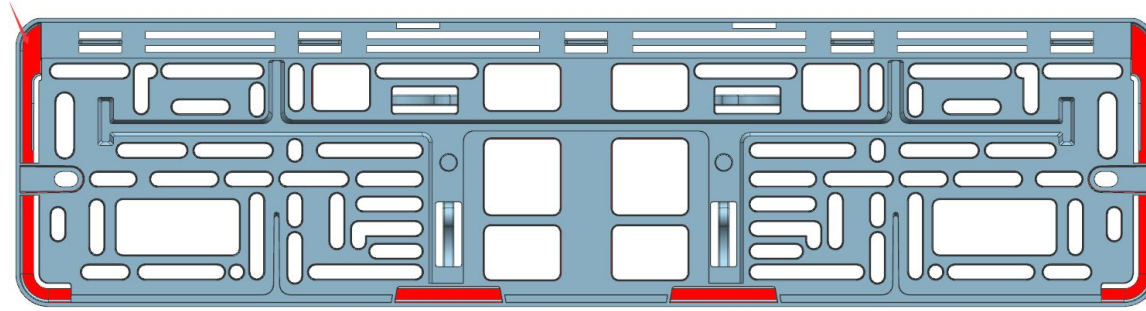

这张面加了斜度, 方便斜顶脱模

From UNION (Author: Erik)	From	Ok/Not	Reply time
Can we add angle on lifter, it will be easier for mold ejection			

Thank You For Reading !
感谢您的阅读！

