

SAFETY RULES FOR OPERATION OF WELLS

Presented by: Almara Seitkaliyeva





SAFETY OPERATIONAL INSTRUCTIONS

A. GENERAL SAFETY

- **Protect your eyes by wearing safety glasses.**
- **Wear shoes with oil resistant soles.**
- **If you have long hair, tie it back.**
- **Do not wear long sleeves, loose clothing or neck ties.**
- **Make sure that your area is free from chips, oil and coolant spills, air hoses or anything that may get in your way and make you to fall or slip.**
- **Make sure that all cutting tools and work holding equipment are tight before running the spindle or moving the slides.**
- **All maintenance and repair work should be done with the power off. If any work requires power ON, extreme care should be taken.**
- **Keep the machine always clean and keep away the tools and gauges from getting damaged.**

The drill press comes in a floor or bench-mounted model. It has a motor driven head that has a chuck that accepts bits or cutters. It also has an adjustable table on which the work is mounted. It is operated by pulling a rotary lever which lowers the drill bit into the material. To avoid accidents, the following operational safety rules must be observed by everyone working on the Drill Press. Failure to follow the safety rules will result in serious accidents.

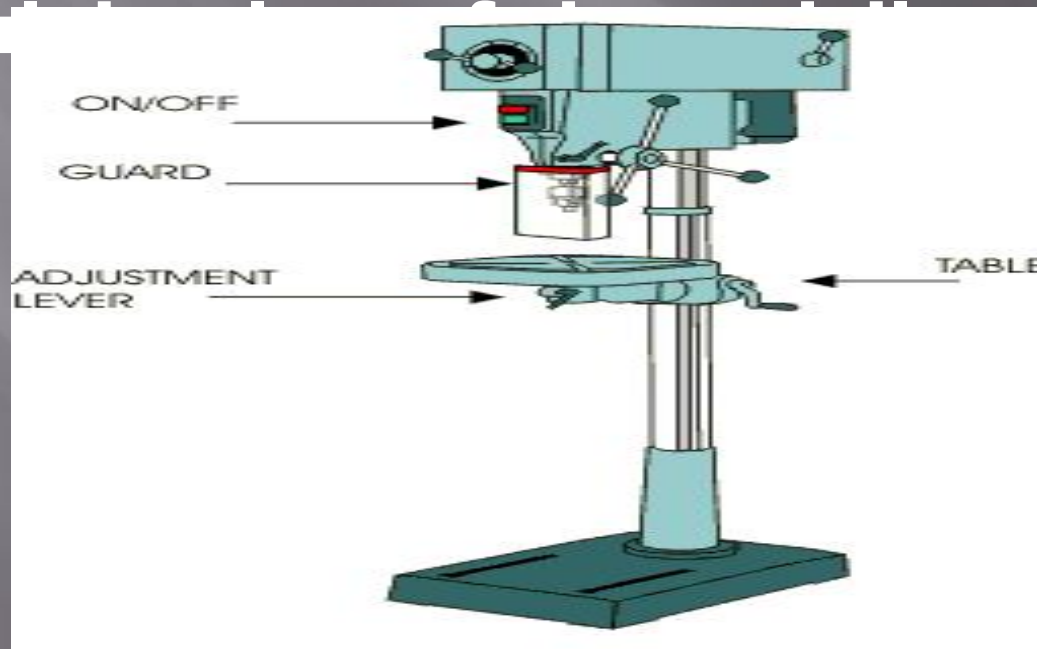



 **CAUTION**



**SAFETY
SHOES
REQUIRED**



***Thank you for your
Attention!***