

ИННОВАЦИИ В ОБЛАСТИ ПРИГОТОВЛЕНИЯ АБС

Инновации установок циклического действия

Инновации установок непрерывного действия



LINTEC GMBH&CO.KG



LINTEC CSD 1200

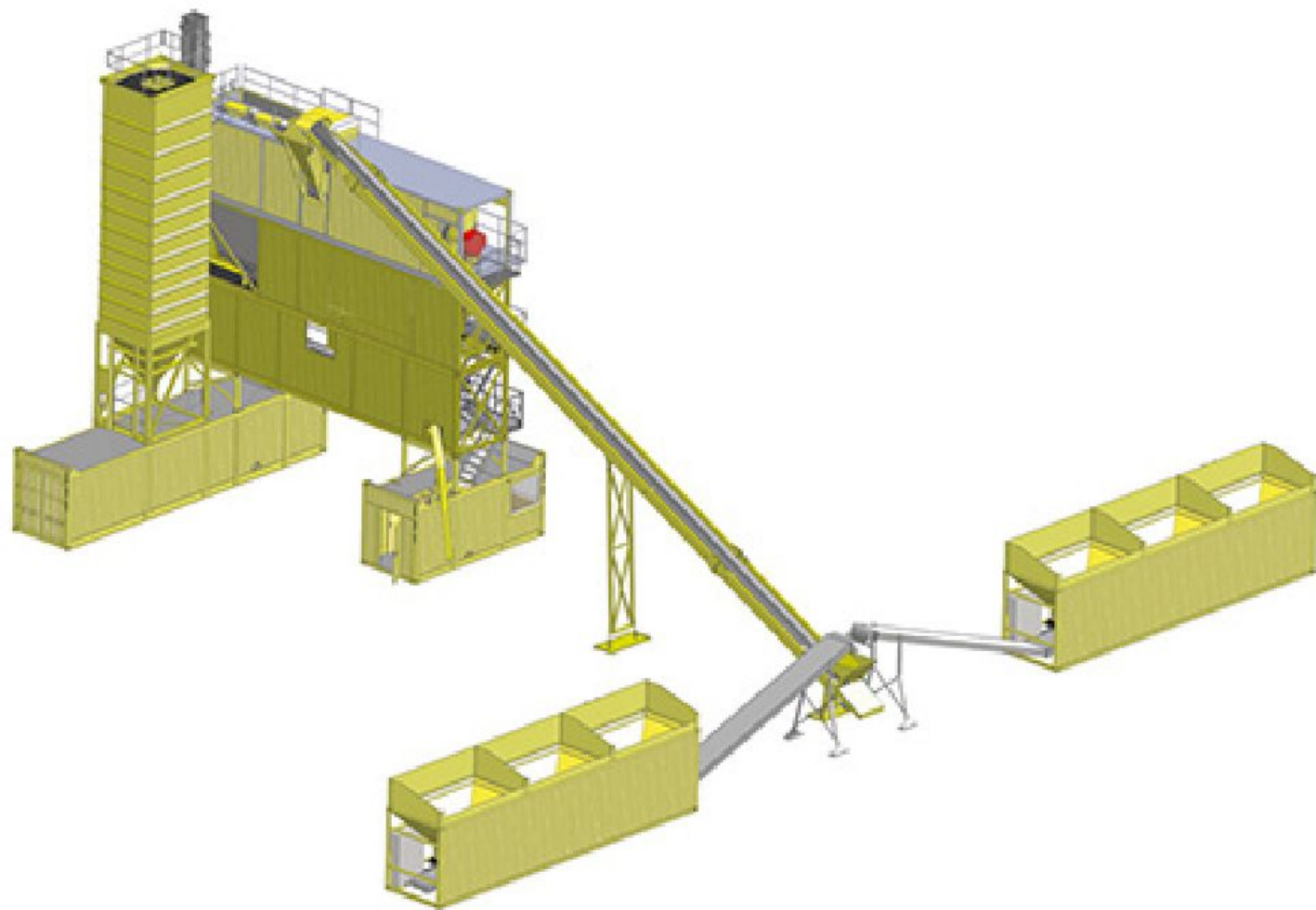

LINTEC CSD 2500 / 2500 B



СОРТИРОВОЧНО-СУШИЛЬНЫЙ БАРАБАН LINTES

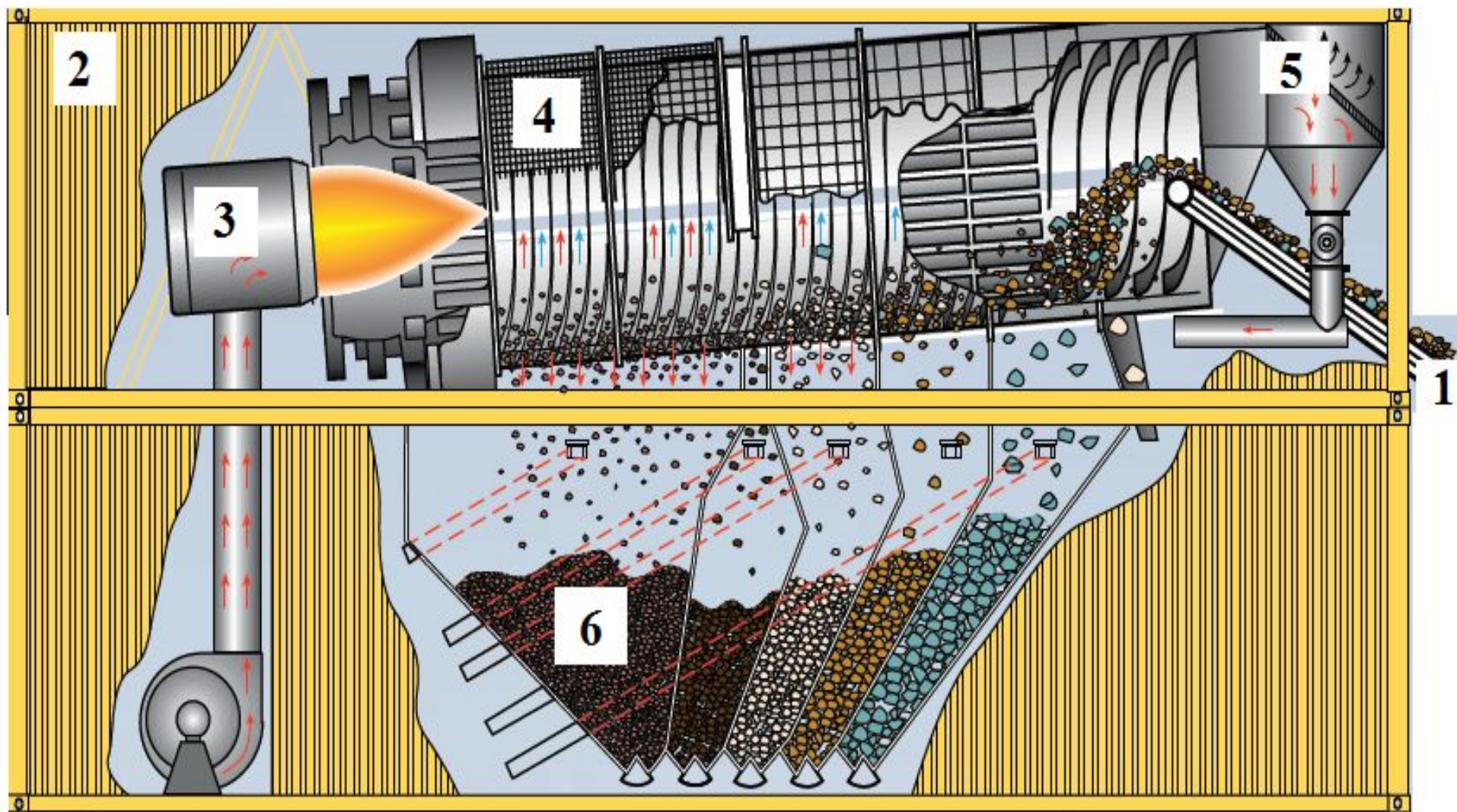

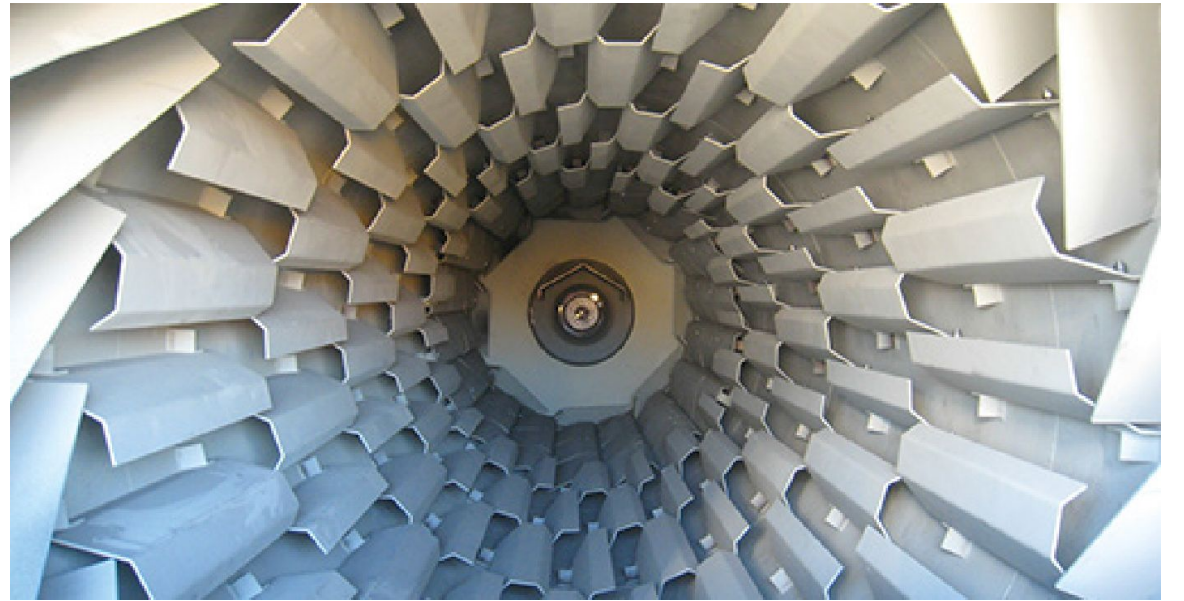

BERNARDI





ТРАДИЦИОННАЯ ТЕХНОЛОГИЯ ХРАНЕНИЯ
И ДОЗИРОВАНИЯ ИНЕРТНЫХ МАТЕРИАЛОВ

Материалы BENNINGHOVEN

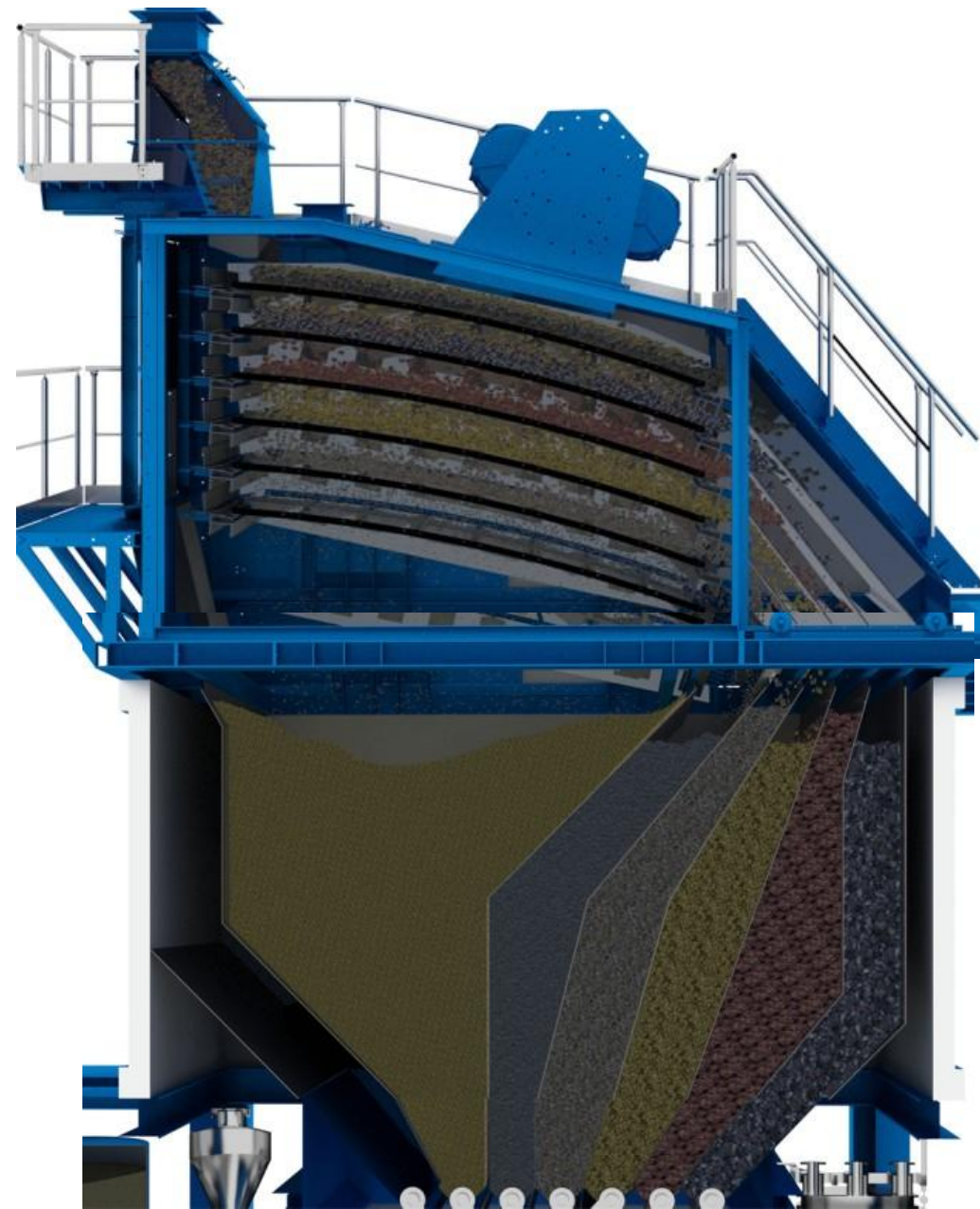

ТРАДИЦИОННАЯ ТЕХНОЛОГИЯ ХРАНЕНИЯ И ДОЗИРОВАНИЯ ИНЕРТНЫХ МАТЕРИАЛОВ

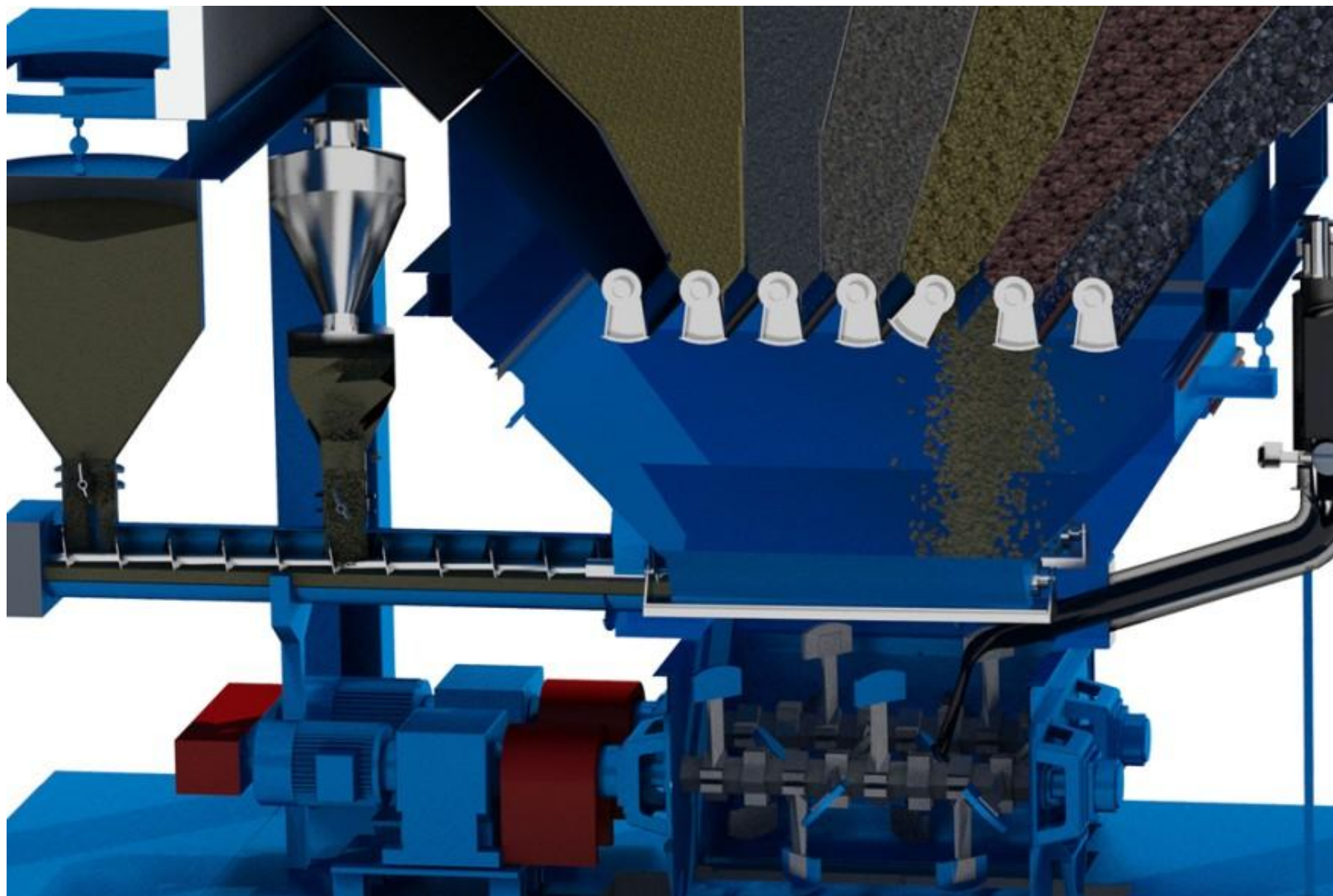

ТЕХНОЛОГИЯ ХРАНЕНИЯ И ДОЗИРОВАНИЯ ИНЕРТНЫХ МАТЕРИАЛОВ BERNARDI MET

MET (Multi Ecological Tower)

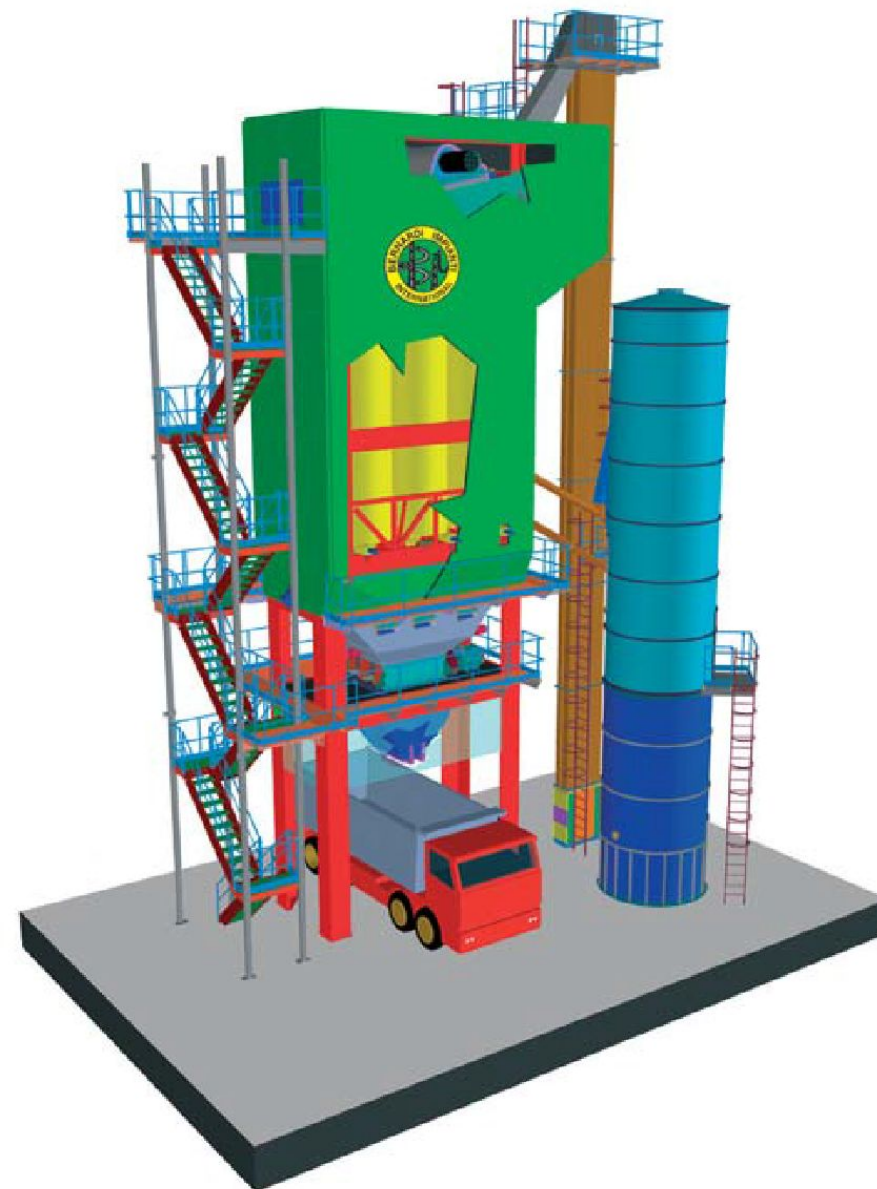
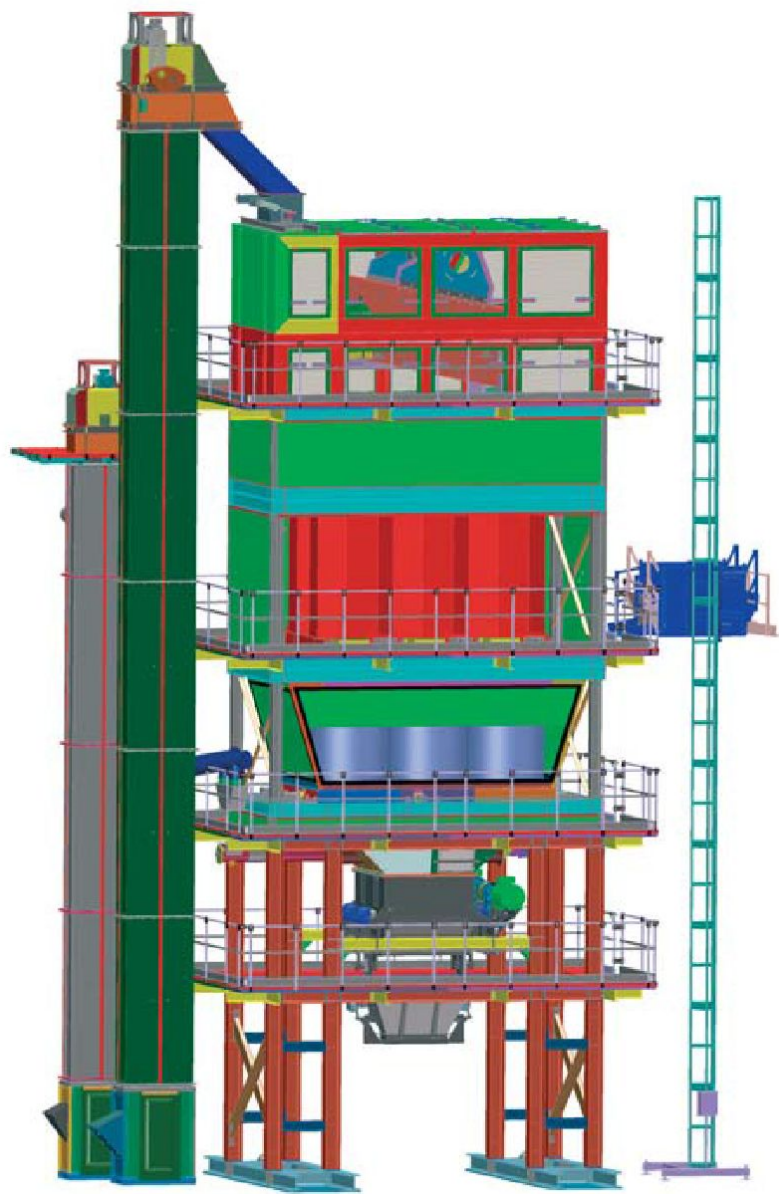

AMOMATIC



ТЕХНОЛОГИЯ УПРАВЛЕНИЯ СКОРОСТЬЮ ВРАЩЕНИЯ СУШИЛЬНОГО БАРАБАНА АМОМАТИС



MEEKER



ТЕПЛОВАЯ ИЗОЛЯЦИЯ СУШИЛЬНОГО БАРАБАНА МЕЕКЕР

Before



After

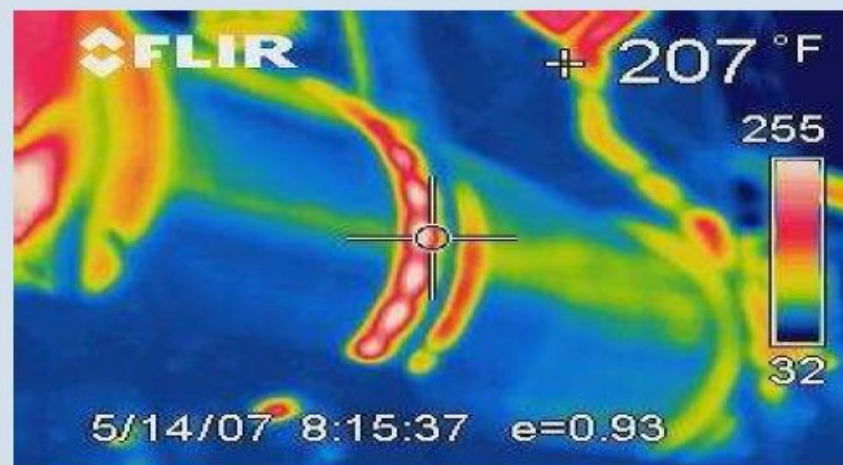

ЛЕНТОЧНЫЙ ТРАНСПОРТЕР MEEKER



ASTECC INDUSTRIES, INC



АГРЕГАТ ПИТАНИЯ ASTEC INC

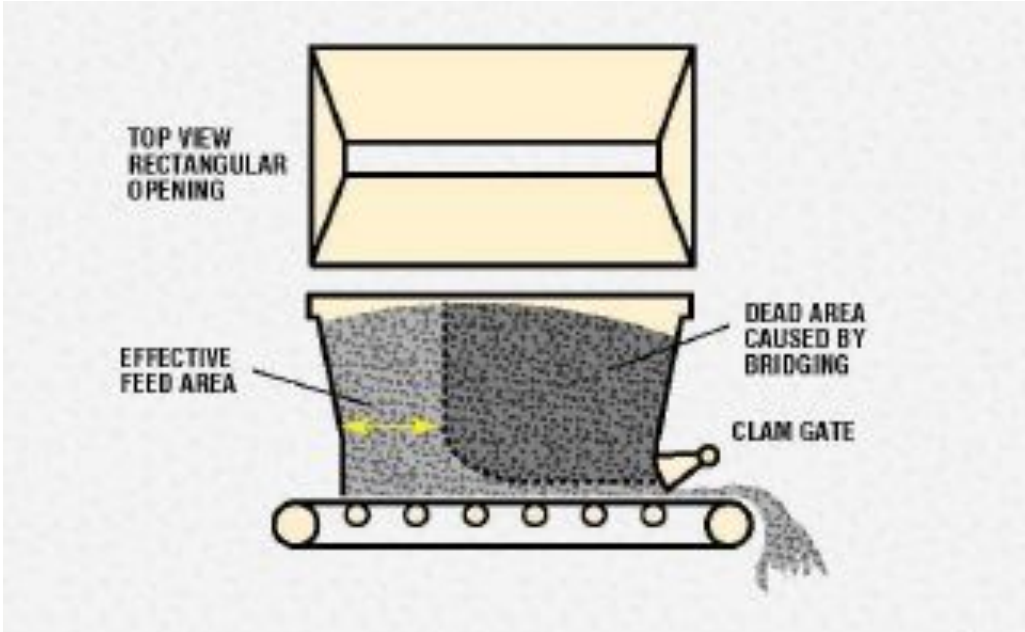

Вид сверху на саморазгружающееся отверстие

Эффективная зона питания

Грейферный затвор

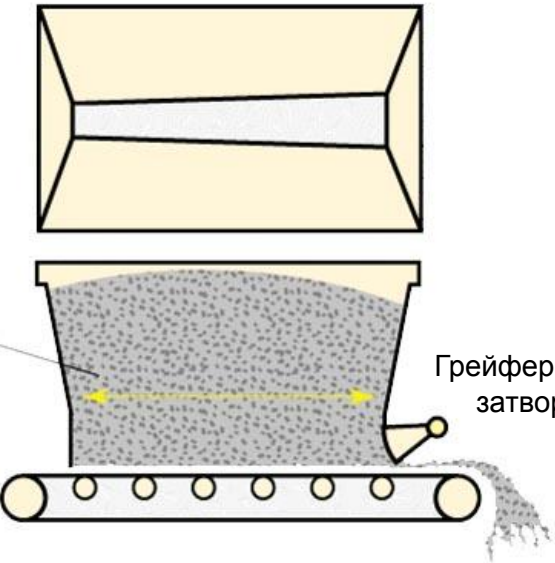

ТЕХНОЛОГИЯ ДВОЙНОЙ БАРАБАН ASTEC INC

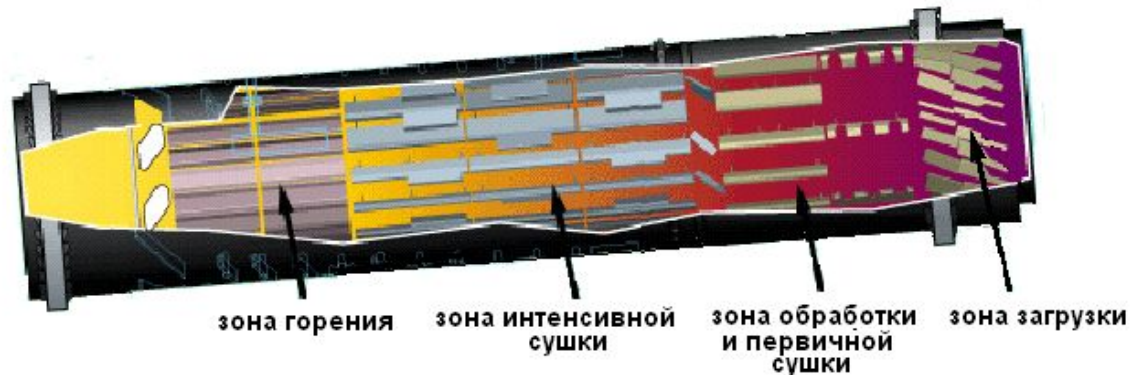
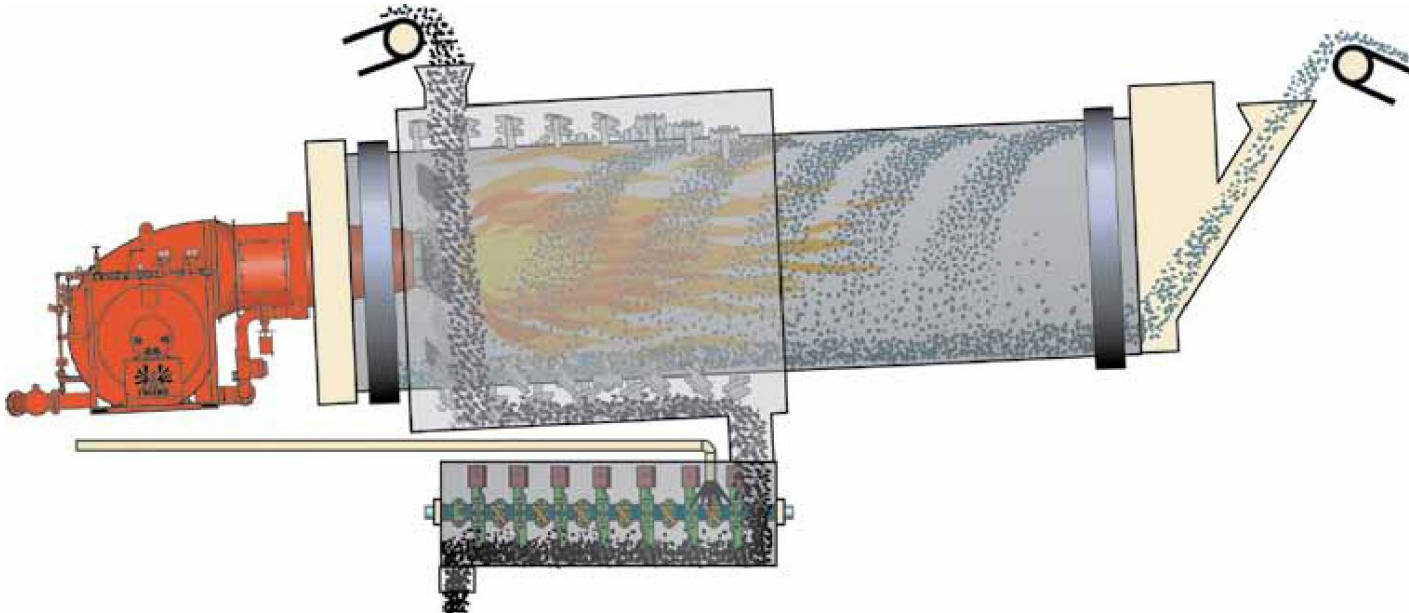

ВНУТРЕННИЙ БАРАБАН ASTEC INC

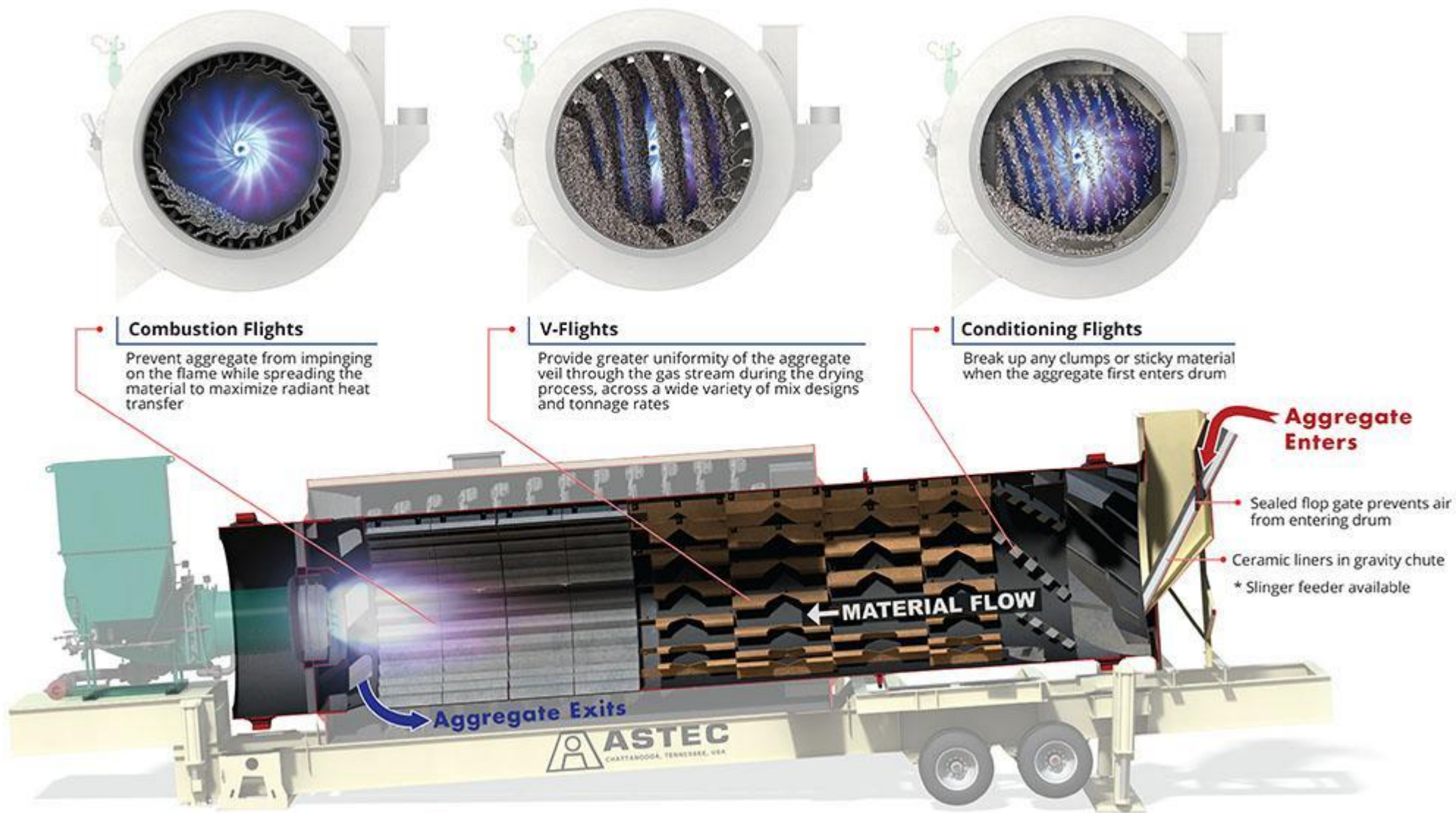

ВНЕШНИЙ БАРАБАН ASTEC INC



RAP (Recycled Asphalt Pavement)

RAP material is added to the aggregate in the mixing chamber



Liquid Asphalt

Liquid asphalt is injected into the mixing chamber through the AC inlet or optional Warm Mix System

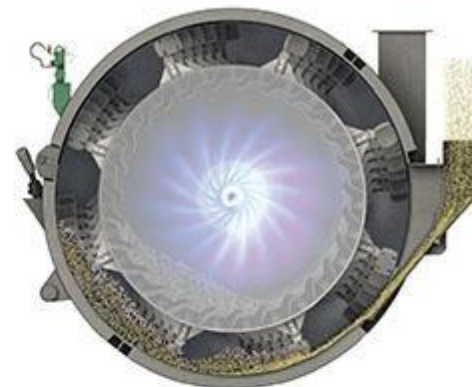

Fine Additives

Baghouse fines are added last so they do not absorb the liquid AC before it is distributed on the aggregate

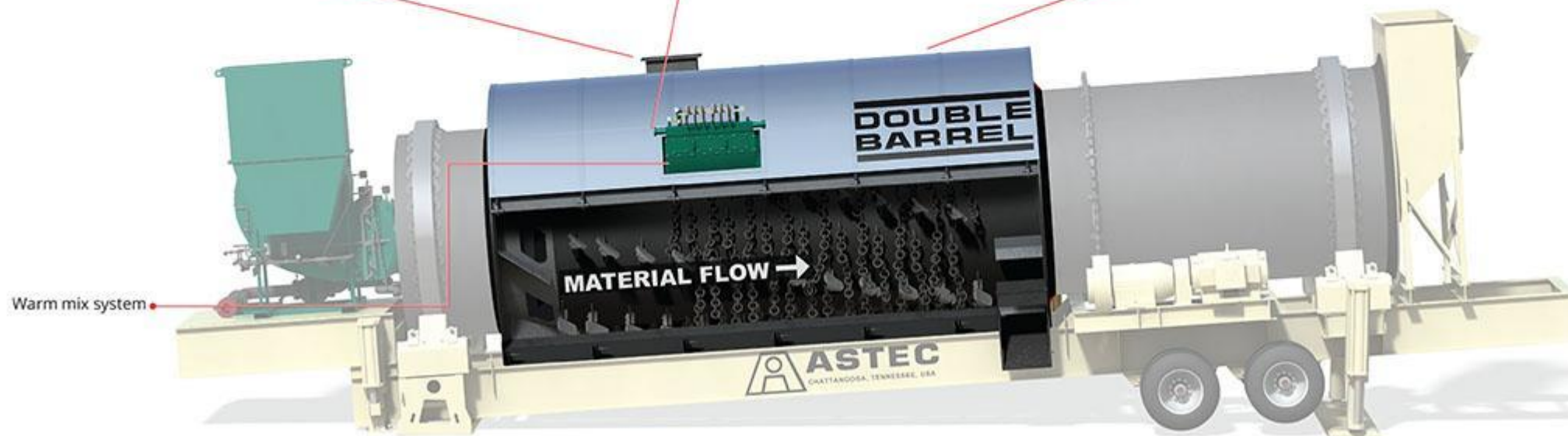

ЛОПАСТИ С V-ОБРАЗНЫМ ВЫРЕЗОМ ASTEC INC

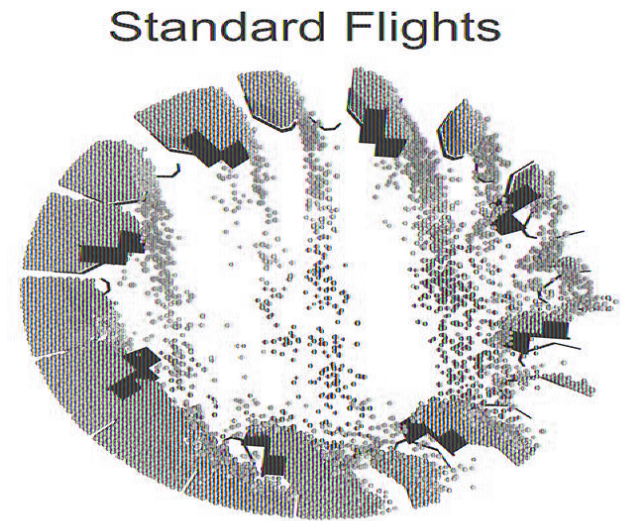
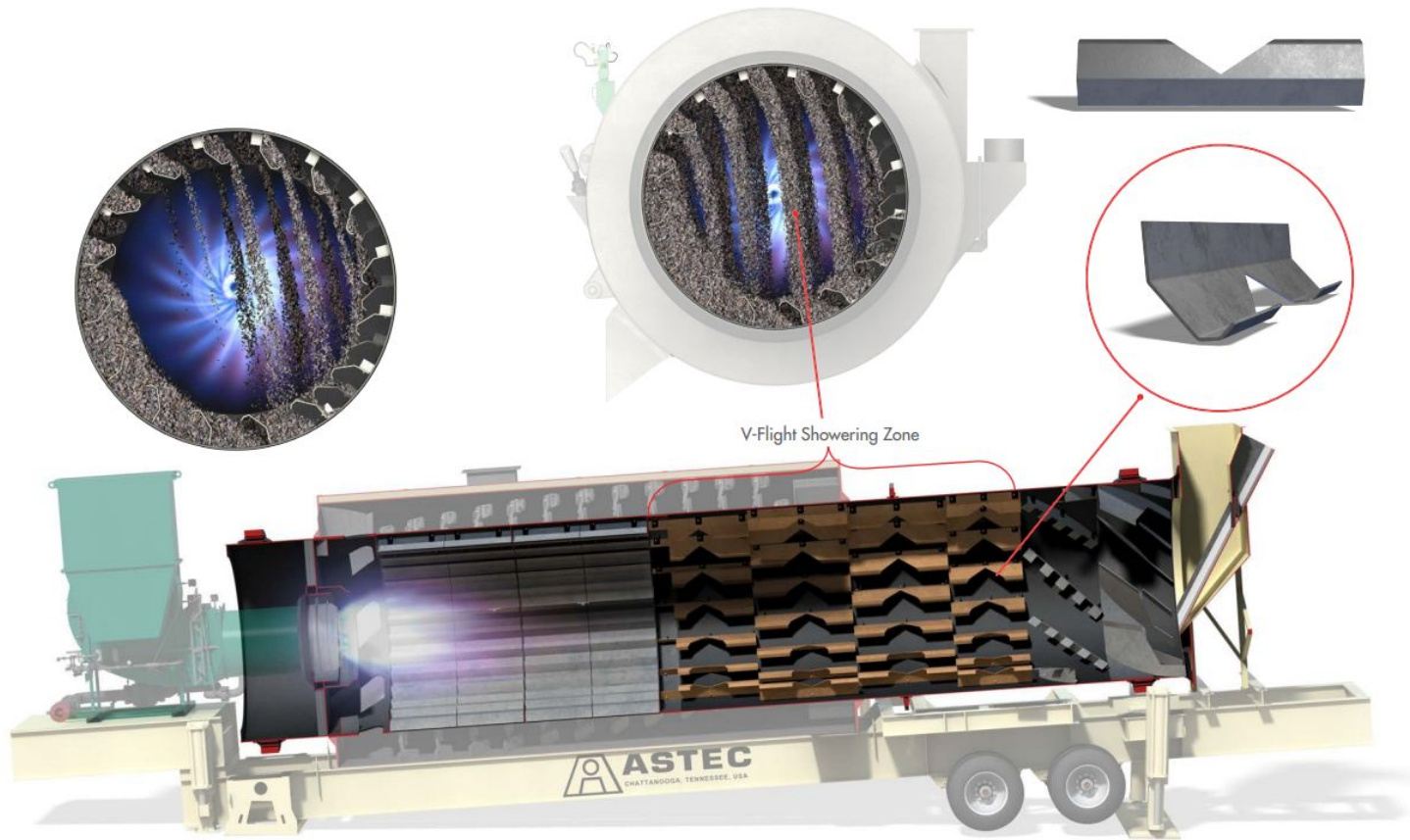

ВНЕШНИЙ БАРАБАН ASTEC INC

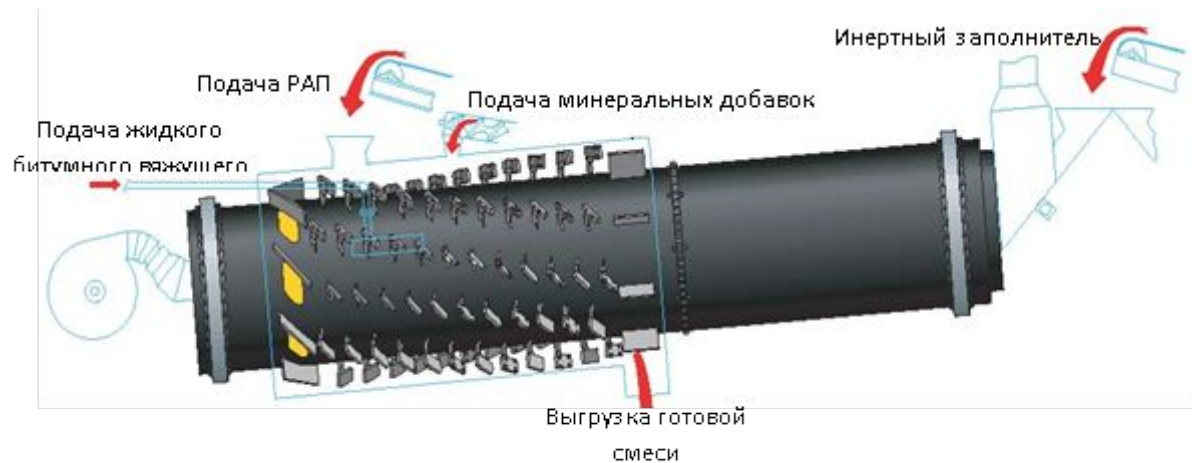

ПОТОК ВОЗДУХА И ПАРОВ ASTEC INC

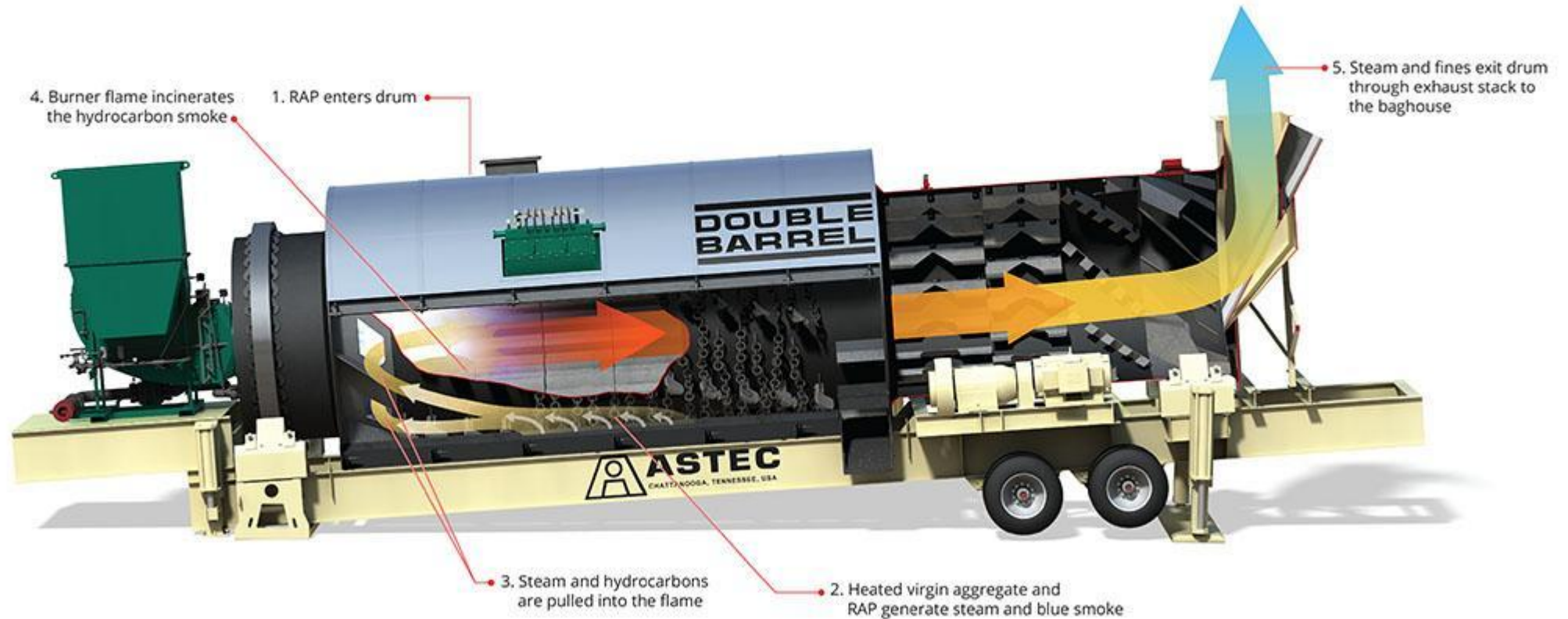

The Cleaning Process

- ➔ Dirty Air
- ➔ Clean Air

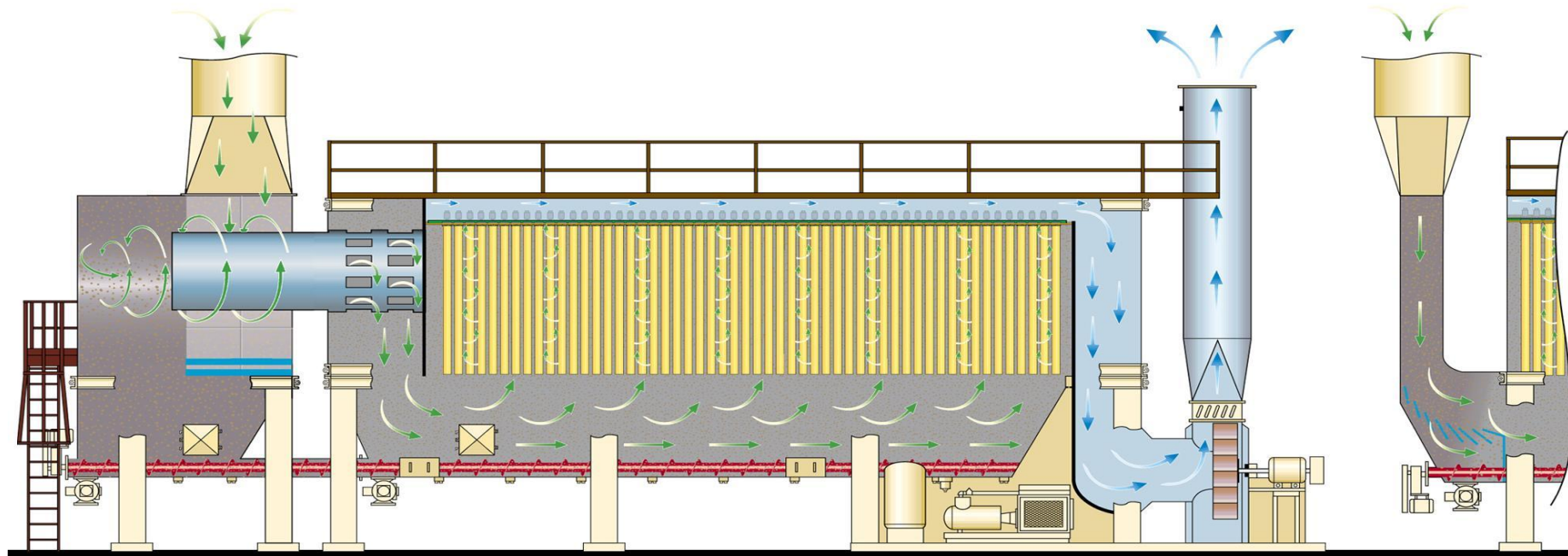

AIR FLOW

