











POPULATION



Iceland



China



Mexico











Africa

Asia

Europe



JUNE



SEPTEMBER



JANUARY











MONDAY



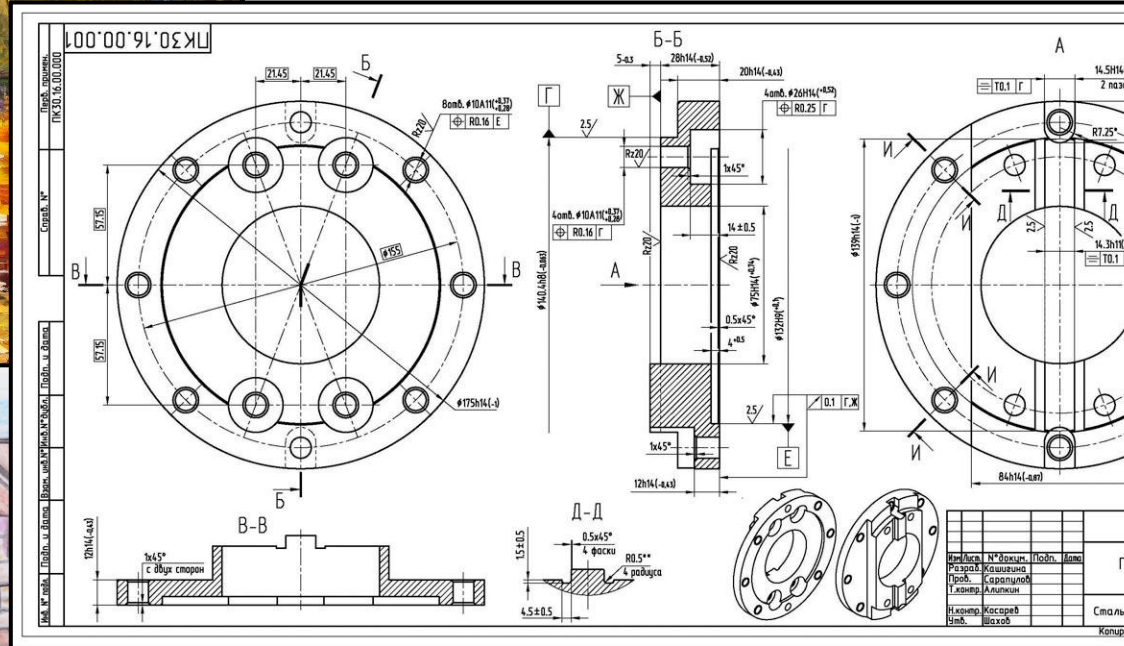





Test



Exam

A+

Five-paragraph essay

Intro: The food in the cafeteria is bad. It lacks variety, it's unhealthy, and it is always overcooked. In this essay I will discuss these three characteristics.

Body paragraph one: The first reason cafeteria food is bad is that there is no variety. (Plus examples, e.g., no salad bar, mostly fried food, etc.)

Body paragraph 2: Another reason cafeteria food is so bad is that it is not healthy. (Plus reasons, e.g., high cholesterol, too many hot dogs, too much sugar, etc.)

Body paragraph 3: In addition, the food is always overcooked. (Plus examples, e.g., vegetables are mushy, "mystery" meat is always tough, etc.)

Conclusion: Thus, we see. . . (re-statement of introduction and thesis)